



Badji Mokhtar University - Annaba
Faculty of Sciences
Physics Department



Electricity and Electromagnetism

Courses and corrected exercises

*First-year LMD Science and Technology (ST)
and Matter Science (MS)*

DRABLIA Samia

2023/2024



Badji Mokhtar University -Annaba

Faculty of Sciences

Physics Department



ELECTRICITY

and

ELECTROMAGNETISM

Courses and corrected exercises

*First-year LMD Science and Technology (ST)
and Matter Science (MS)*

DRABLIA Samia

2023/2024

Foreword

This course “Electricity and Electromagnetism” or “Physics 2” is aimed at students in the core areas (first year) of science and technology (ST), material sciences (SM), mathematics and computer science (MI).

These courses introduce basic concepts of electricity and electromagnetism, and study the interaction between static and moving charged particles.

This “physics 2” course is made up of four chapters consistent with the programs for the second semester.

The first chapter gives the main notions of Electrostatics.

The second chapter is dedicated to the conductors.

The third chapter is devoted to the Electrokinetics

The last chapter concerns electromagnetisme.

To achieve a correct understanding of the lessons, we have included with each chapter a set of exercises with the typical and detailed solution.

I express my sincere gratitude to all those who contributed their expertise to the creation of this handout. May it guide you on your own journey through the wonders of electricity and electromagnetism, illuminating new avenues of understanding and inspiring boundless curiosity.

DRABLIA Samia

Contents

<u>Chapter 1: Electrostatics</u>	1
I.1. Introduction	3
I.2. Electrification experiments	3
I.2.1. Electrification by friction	3
I.2.2. Contact electrification	3
I.2.3. Electrification by influence	3
I.3. The electrical charge	4
I.4. Conductive materials, insulating	4
I.5. Coulomb's law	5
I.6. The electrostatic field	7
I.7. The electrostatic potential	9
I.8. Electric dipole	13
I.9. Electric field created by a continuous distribution of charges	18
I.10. Gauss's theorem	18
Exercises	21
Solution	24
<u>Chapter 2: conductors</u>	39
II.1. Definitions	40

II.2. Properties of a conductor in electrostatic	40
II.3. Field in the vicinity of a conductor in equilibrium: Coulomb's theorem	40
II.4. Electrostatic pressure	43
II.5. Peak effect: Distribution of charges on a	44
II.6. Capacity of a driver isolated	44
II.7. Internal energy of an isolated charged conductor	45
II.8. Influence phenomena between charged conductors	45
II.9. Capacitor	50
Exercises	54
Solution	57
<u>Chapter 3: Electrokinetics</u>	65
III.1. Introduction	67
III.2. Electrical conductor	67
III.3. Electric current	67
III.4. Ohm's law	70
III.5. The Joule Effect and Electric Power	72
III.6. Association of Resistors	73
III.7. Electrical circuits	74
III.8. Kirchhoff's laws	77
III.9. Thevenin's theorem	79
Exercises	80
Solution	82

<u>Chapter 4: Electromagnetism</u>	87
IV.1. Introduction	69
IV.2. Definition	89
IV.3. Action of a magnetic field on the movement of an electric charge	90
IV.3.1. Lorentz force	90
IV.4. action of a magnetic field on an electric current	91
IV.4.1. Laplace force	91
IV.5. Magnetic field created by a current	92
IV.5.1. Biot and Savart's law	92
IV.6. Ampere's theorem	93
IV.7. Faraday's law	94
IV.8. Lenz's law	94
Exercises	96
Solution	98
<u>Bibliography</u>	101

Chapter 1

Electrostatics

Electrostatics: Coulomb's Law

The MAN: Charles Augustin de Coulomb



He was born in 1736 in Angoulême, France.

He received the majority of his higher education at the Ecole du Genie at Mezieres (sort of the French equivalent of universities like Oxford, Harvard, etc.) from which he graduated in 1761.

He then spent some time serving as a military engineer in the West Indies and other French outposts, until 1781 when he was permanently stationed in Paris and was able to devote more time to scientific research. Between 1785-91 he published seven memoirs (papers) on physics.

Gauss



- Johann Carl Friedrich Gauss (30 April 1777 – 23 February 1855) was a German mathematician and scientist who contributed significantly to many fields, including number theory, statistics, analysis, differential geometry, geodesy, geophysics, electrostatics, astronomy and optics.
- Sometimes referred to as "the Prince of Mathematicians", Gauss had a remarkable influence in many fields of mathematics and science and is ranked as one of history's most influential mathematicians.
- He referred to mathematics as "the queen of sciences".

I.1. Introduction

Electrostatics is a part of electricity that focuses on phenomena created by fixed (immobile) electrical charges. This branch studies the interactions between these charges.

I.2. Electrification experiments

Electrification represents a charge transfer phenomenon. There are three types of electrification of an object: by friction, by contact and by influence.

I.2.1. Electrification by friction

We rub a plastic or glass ruler with wool and bring it close to the small pieces of paper, it attracts it. Without friction, nothing happens, after friction the ruler will be electrified (charged).

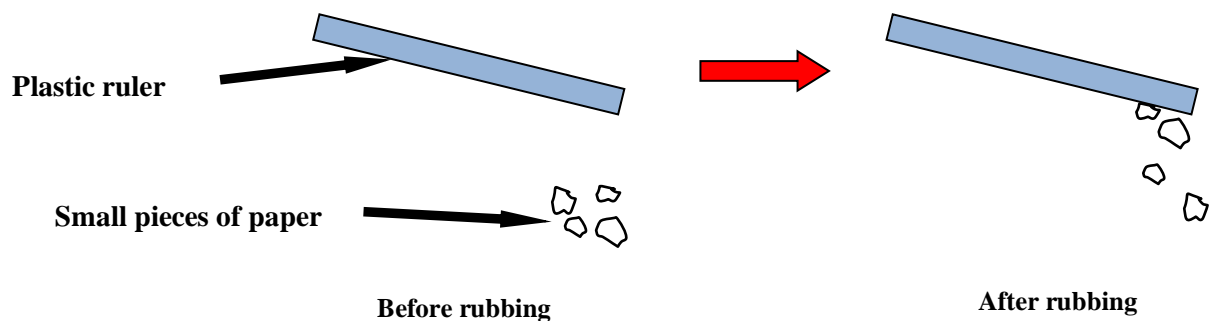

I.2.2. Contact electrification

Contact electrification is the transfer of electrons from a charged body to another uncharged body (electrically neutral), so the electrons move towards it and it has the same type of charges and therefore repulsion occurs.

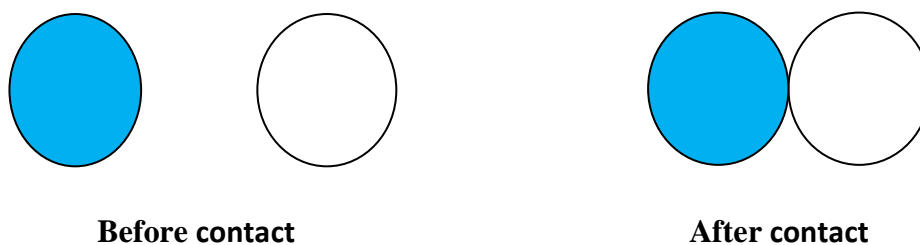

I.2.3. Electrification by influence

We approach a neutral rod to an electrified ball, without touching it. We notice that the ball is attracted towards the rod, we see that it has been electrified by influence. When the rod is moved away, the pendulum returns to its initial position

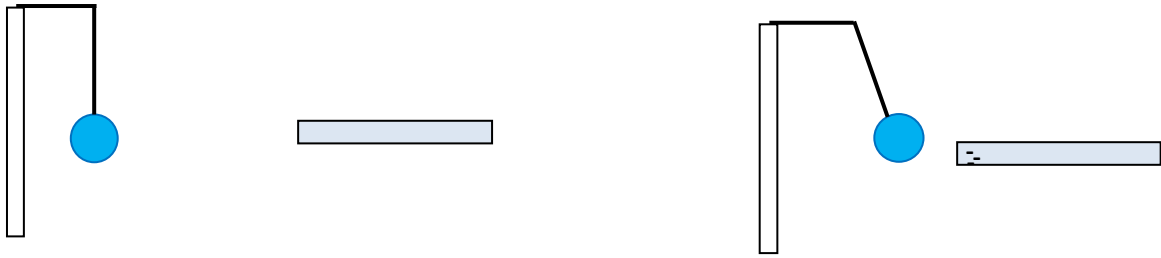

I.3. The electrical charge

I.3.1. Definition of electrical charge

The atom is the smallest particle of a body that can exist. A body is made up of an assembly of atoms. The atom consists of a nucleus around which electrons revolve. The nucleus is made up of two particles called nucleons. These particles are protons and neutrons. The number of protons in an atom is equal to the number of electrons.

The electrical charge is a scalar quantity, like mass, represents a fundamental property of matter, which makes it possible to explain certain phenomena (electrostatics, electromagnetism, etc.), it is denoted q and its unit in SI is the Coulomb (C). There are two types of electrical charges, *positive* and *negative*. Two charges of the same sign repel each other and two charges of opposite signs attract each other.

I.3.2. The elementary charge

It is the smallest amount of charge $e = 1.602176634 \times 10^{-19} \text{ C}$, the electric charge of an electron: $q_e = -e = -1.602176634 \cdot 10^{-19} \text{ C}$

proton: $q_p = +e = 1.602176634 \cdot 10^{-19} \text{ C}$.

I.3.3. The point charge

Is an electric charge localized at a dimensionless point. Hence, the characteristic of a point charge is: It takes up no space and acts uniformly on its surroundings

I.3.4. Conservation of electrical charge

In an isolated body the algebraic sum of the electric charges remains constant:

$$q_{final} = q_{initial}$$

I.4. Conductive materials, insulating

From an electrical point of view, there are two main families of materials: conductors and insulators.

I.4.1. Conductive materials

In conductors, electrical charges are free to move and are distributed throughout the material. An electrical conductor therefore conducts electric current (iron, aluminum, salt water, etc.).

I.4.2. Insulating materials (dielectric)

Conversely, an electrical insulator is a medium that does not conduct electric current , because it does not allow the passage of free electrons from one atom to another (ebonite, glass, porcelain, plastics, etc.) , the insulation is charged by friction (rubbing).

I.5. Coulomb's law

I.5.1. interaction between two point charges q₁ and q₂

Consider two point charges q₁ and q₂ separated by r placed in a vacuum. The first exerts a force on the second \vec{F}_{12} , the second exerts a force on the first \vec{F}_{21} .

Coulomb's law allows us to determine the electrostatic force, which is written:

$$\vec{F}_e = \vec{F}_{12} = -\vec{F}_{21} = K \frac{q_1 q_2}{r^2} \vec{u} \Rightarrow F_e = F_{12} = F_{21} = K \frac{|q_1| \cdot |q_2|}{r^2}$$

$$K = \text{constante} = \frac{1}{4\pi\epsilon_0} = 8,9875 \cdot 10^9 \text{ Nm}^2\text{C}^{-2},$$

we will often use the value $9 \cdot 10^9 \text{ Nm}^2\text{C}^{-2}$.

$\epsilon_0 = 8.8542 \cdot 10^{-12} \text{ C}^2/\text{Nm}^2$ is the permittivity.

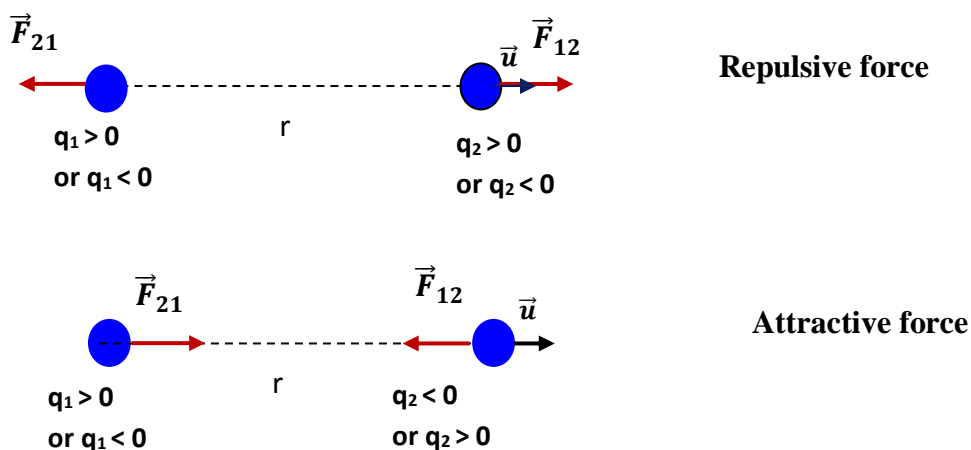

Note :

In a medium other than vacuum, ϵ_0 will be replaced by $\epsilon = \epsilon_0 \epsilon_r$ where ϵ_r represents the relative permittivity, therefore the force is given by the following relation:

$$\vec{F}_e = \frac{q_1 q_2}{4\pi\epsilon_0\epsilon_r r^2} \vec{u} \Rightarrow F_e = \frac{|q_1| \cdot |q_2|}{4\pi\epsilon_0\epsilon_r r^2}$$

Example:

Calculate the force exerted by the charge $q_1 = 6 \cdot 10^{-4} \text{ C}$ on a charge $q_2 = -3 \cdot 10^{-4} \text{ C}$ separated by the distance 9 mm.

Solution:

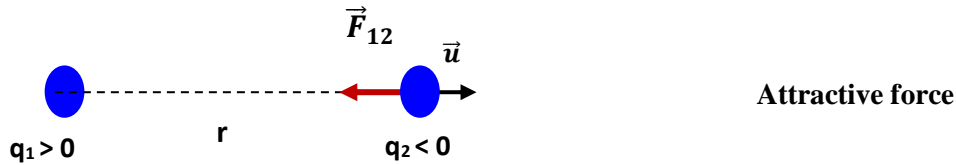

$$\vec{F}_e = \vec{F}_{12} = K \frac{q_1 q_2}{r^2} (-\vec{u}) \Rightarrow F_e = F_{12} = K \frac{|q_1| \cdot |q_2|}{r^2}$$

$$F_{12} = K \frac{|q_1| \cdot |q_2|}{r^2} = 9 \cdot 10^9 \frac{|6 \cdot 10^{-4}| \cdot |-3 \cdot 10^{-4}|}{(9 \cdot 10^{-3})^2} = 9 \cdot 10^9 \frac{6 \cdot 10^{-4} \cdot 3 \cdot 10^{-4}}{81 \cdot 10^{-6}} = 2 \cdot 10^7 \text{ N}$$

$$\boxed{F_{12} = 2 \cdot 10^7 \text{ N}}$$

1.5.2. Principle of superposition

Assuming that there exist n immobile electric charges in a vacuum. The electrostatic force exerted by the n charges on a charge q located at a point M is:

$$\vec{F}_1 = K \frac{q_1 q}{r_1^2} \vec{u}_1, \vec{F}_2 = K \frac{q_2 q}{r_2^2} \vec{u}_2, \dots, \vec{F}_n = K \frac{q_n q}{r_n^2} \vec{u}_n$$

$$\vec{F}(M) = \vec{F}_1 + \vec{F}_2 + \vec{F}_n$$

$$\vec{F}(M) = K \frac{q \cdot q_1}{r_1^2} \vec{u}_1 + K \frac{q \cdot q_2}{r_2^2} \vec{u}_2 + \dots + K \frac{q \cdot q_n}{r_n^2} \vec{u}_n$$

$$\Rightarrow \vec{F}(M) = \sum_{i=1}^n K \frac{q \cdot q_i}{r_i^2} \vec{u}_i$$

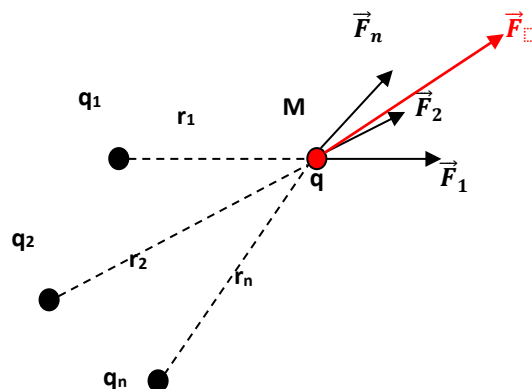

I.6. The electrostatic field

I.6.1. Definition

Coulomb's law can be written as follows

$$\vec{F} = K \frac{qq'}{r^2} \vec{u} = q' K \frac{q}{r^2} \vec{u} = q' \vec{E}$$

A point charge q located at O , creates at any point M in space (in a vacuum), an electrostatic field \vec{E} , given by the following relation:

$$\vec{E} = K \frac{q}{r^2} \vec{u} \Rightarrow E = K \frac{|q|}{r^2}$$

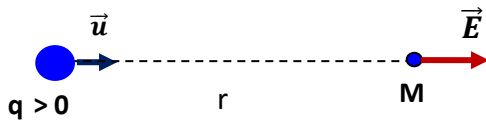

The electrostatic field directs the charge outwards

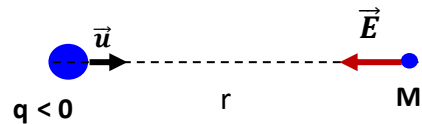

The electrostatic field directs towards the charge

- The unit of E in SI is Volt/meter (V/m)
- $\vec{E} = \frac{\vec{F}}{q}$. If $q' > 0$, \vec{E} and \vec{F} have the same direction and if $q' < 0$, \vec{E} and \vec{F} are of opposite directions.

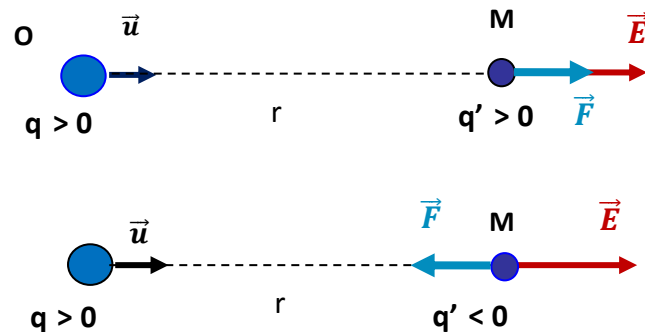

I.6.2. Electrostatic field created by a set of point charges

Consider n charges located at points P_i , the electrostatic field produced by these charges at point M is the vector sum of all the fields due to each of the charges.

So we have:

$$\vec{E}(M) = \vec{E}_1 + \vec{E}_2 + \dots + \vec{E}_n$$

$$\vec{E}_1 = K \frac{q_1}{r_1^2} \vec{u}_1, \quad \vec{E}_2 = K \frac{q_2}{r_2^2} \vec{u}_2, \quad \dots \vec{E}_n = K \frac{q_n}{r_n^2} \vec{u}_n$$

$$\vec{E}(M) = K \frac{q_1}{r_1^2} \vec{u}_1 + K \frac{q_2}{r_2^2} \vec{u}_2 + \dots + K \frac{q_n}{r_n^2} \vec{u}_n$$

$$\vec{E}(M) = K \sum_{i=1}^n \frac{q_i}{r_i^2} \vec{u}_i$$

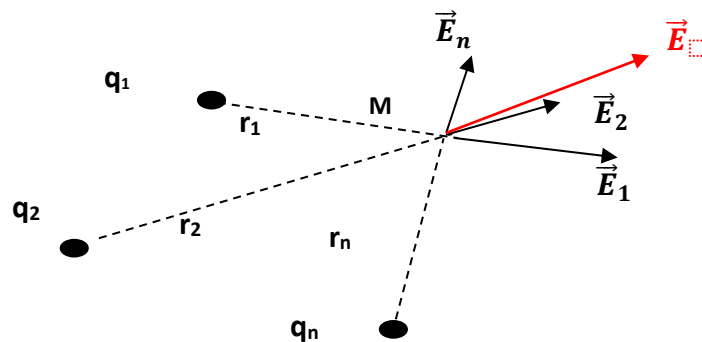

1.6.3. Field lines

Electric field lines are an excellent way of visualizing electric fields. A field line is drawn tangential to the net at a point. Thus at any point, the tangent to the electric field line matches the direction of the electric field at that point. Secondly. In other words, if you see more electric field lines in the vicinity of point A as compared to point B, then the electric field is stronger at point A.

Properties of Electric Field Lines

- The field lines never intersect each other.
- The field lines are perpendicular to the surface of the charge.
- The magnitude of charge and the number of field lines, both are proportional to each other.
- The start point of the field lines is at the positive charge and end at the negative charge.
- For the field lines to either start or end at infinity, a single charge must be used.

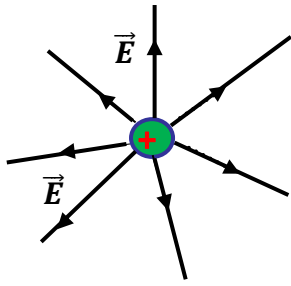

case of a positive charge

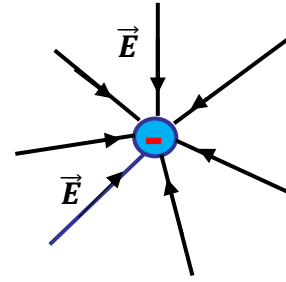

case of a negative charge

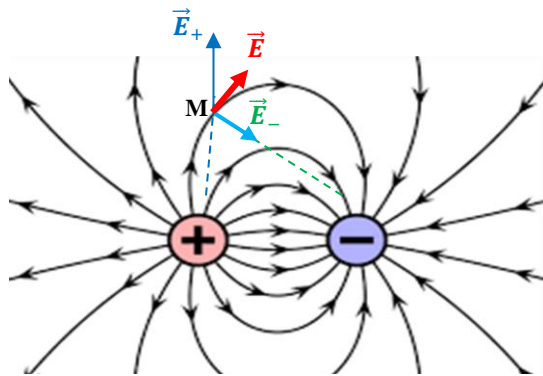

Case of two opposite charges (dipole)

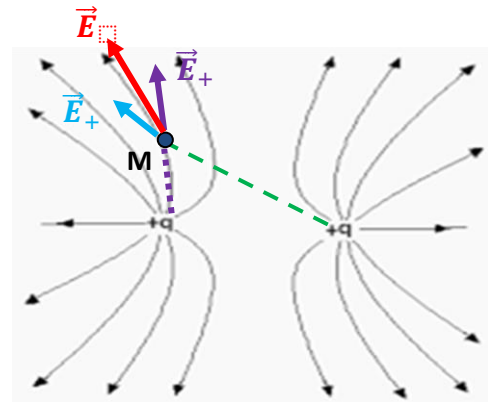

Case of two positive charges

I.7. The electrostatic potential

The electrostatic potential is a scalar physical quantity which defines the electrical state of a point in space. It corresponds to the electrostatic potential energy (measured in joules) of a charged particle at this point divided by the charge (measured in coulomb) of the particle. So to determine the expression of the potential it is necessary to calculate the potential energy.

I.7.1. Interaction energy between two point charges

To introduce the notion of electrostatic potential, let us look at the interaction between two electric charges q and Q . According to Coulomb's law, the charge q experiences a force:

$$\vec{F} = K \frac{qQ}{r^2} \vec{u}$$

In mechanics, we know that a force \vec{F} applied to an object that moves a elementary distance \vec{dl} provides a work dW

$$dW = \vec{F} \cdot d\vec{l}$$

Suppose a charge q moves in a space from a point A at a point B in an electric field \vec{E} created by Q .

At each position M, it experiences a force:

$$\vec{F} = q \vec{E}$$

$$dW = \vec{F} \cdot d\vec{l} = q\vec{E} \cdot d\vec{l}$$

$$\Rightarrow W = \int_A^B q\vec{E} \cdot d\vec{l} = q \int_A^B \vec{E} \cdot d\vec{l}$$

We call $C = \int_A^B \vec{E} \cdot d\vec{l}$ the **circulation of vector E between A and B**.

we have $E = \frac{Q}{4\pi\epsilon_0 r^2}$

$$\Rightarrow W = \frac{qQ}{4\pi\epsilon_0} \int_A^B \frac{dl \cdot \cos\alpha}{r^2}$$

And we also have $dr = dl \cdot \cos\alpha$

$$\Rightarrow W = \frac{qQ}{4\pi\epsilon_0} \int_A^B \frac{dr}{r^2} = \frac{qQ}{4\pi\epsilon_0} \left[\frac{-1}{r} \right]_{r_1}^{r_2}$$

$$W = \frac{qQ}{4\pi\epsilon_0} \left(\frac{1}{r_1} - \frac{1}{r_2} \right)$$

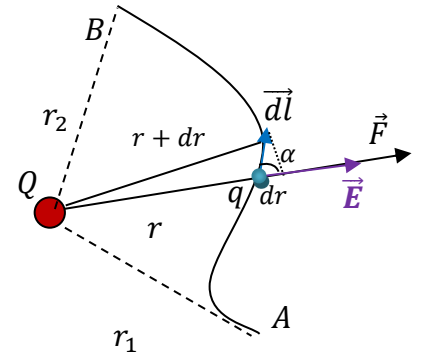

We see that the work does not depend on the path taken by the particle between A and B. As well as the circulation of the field \vec{E} depends only on the initial and final positions. In mechanics, the work is equal to the variation of the potential energy, and we found that the work does not depend on the path followed, therefore it depends on the potential energy E_p measured in the initial and final positions A and B.

$$W = E_p(A) - E_p(B) = -\Delta E_p \Rightarrow dW = -dE_p = \frac{qQ}{4\pi\epsilon_0} \int \frac{dr}{r^2}$$

$$\Delta E_p = E_p(B) - E_p(A) = -\frac{q \cdot Q}{4\pi\epsilon_0} \int_{r_1}^{r_2} \frac{dr}{r^2} \Rightarrow E_p = \frac{qQ}{4\pi\epsilon_0 r} + C$$

When $r \rightarrow \infty \Rightarrow E_p = 0 \Rightarrow c = 0$

$$\text{SO } E_p = \frac{qQ}{4\pi\epsilon_0 r}$$

We call the electric potential V created by the charge q

$$V(r) = \frac{E_p}{Q} = \frac{Kq}{r}$$

□ The potential is expressed in Volt (V) (i.e. in J/C).

Remark:

The circulation of \vec{E} from A to B is therefore equal to the difference between the values of the potential at A and at B:

$$C = \int_A^B \vec{E} \cdot d\vec{l} = -\frac{Kq}{r_B} + \frac{Kq}{r_A} = V(A) - V(B)$$

1.7.2. Relationship between field and electrostatic potential

$$V(r) = \frac{Kq}{r} \Rightarrow dV = -Kq \frac{dr}{r^2} = -\frac{Kq}{r^2} dr = -\frac{Kq}{r^2} dl \cdot \cos\alpha = -\vec{E} \cdot d\vec{l}$$

In an O,x,y,z coordinate system:

$$\vec{E} \begin{pmatrix} E_x \\ E_y \\ E_z \end{pmatrix} \quad \text{and} \quad d\vec{l} \begin{pmatrix} dx \\ dy \\ dz \end{pmatrix}$$

$$\Rightarrow \vec{E} \cdot d\vec{l} = E_x dx + E_y dy + E_z dz$$

$$dV = \frac{\partial V}{\partial x} dx + \frac{\partial V}{\partial y} dy + \frac{\partial V}{\partial z} dz$$

$$\text{by identification: } E_x = -\frac{\partial V}{\partial x}, \quad E_y = -\frac{\partial V}{\partial y} \quad \text{et} \quad E_z = -\frac{\partial V}{\partial z}$$

therefore the vector of the field is written:

$$\vec{E} = E_x \vec{i} + E_y \vec{j} + E_z \vec{k} = -\left(\frac{\partial V}{\partial x} \vec{i} + \frac{\partial V}{\partial y} \vec{j} + \frac{\partial V}{\partial z} \vec{k} \right) = -\overrightarrow{\text{grad}}V$$

$$\vec{E} = -\overrightarrow{\text{grad}}V$$

The gradient operator in Cartesian coordinates is written:

$$\overrightarrow{\text{grad}} = \frac{\partial}{\partial x} \vec{i} + \frac{\partial}{\partial y} \vec{j} + \frac{\partial}{\partial z} \vec{k}$$

We say the electric field \vec{E} derives from potential V .

I.7.3. Principle of superposition

Consider n fixed point charges q_i , placed at points M_i in a vacuum.

The electrical potential created by the whole of these charges at a point M is written:

$$V(M) = V_1 + V_2 + \dots + V_n = K \frac{q_1}{r_1} + K \frac{q_2}{r_2} + \dots + K \frac{q_n}{r_n}$$

$$\Rightarrow V(M) = \sum_{i=1}^n V_i = \sum_{i=1}^n K \frac{q_i}{r_i}$$

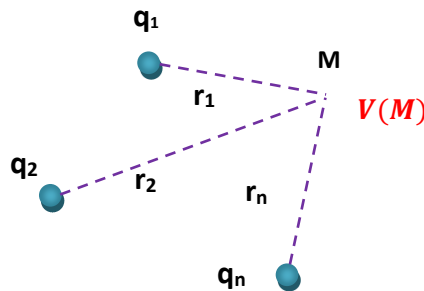

I.7.4. Equipotential surfaces

The equipotential surface is the set of points in space having the same value of electric potential. It is therefore defined by:

$$V(x, y, z) = V_0 = \text{Cste}$$

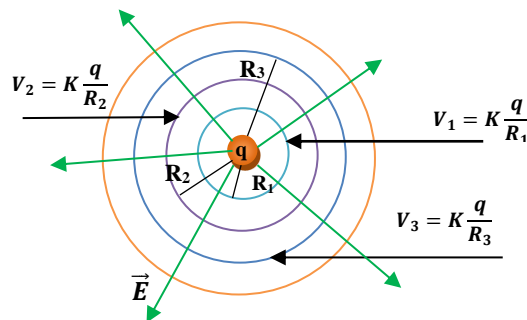

□ For any path \vec{dl} located on the equipotential surface, we have: $\int_A^B \vec{E} \cdot \vec{dl} = 0$.

This shows that everything \vec{dl} on the equipotential surface is perpendicular to \vec{E} .

The equipotential surfaces are therefore perpendicular to the field lines.

I.7.5. Work and potential energy of a moving charge

□ The work of the electrostatic force \vec{F} , and the potential energy, when moving a charge q from point A to point B in an electrostatic field \vec{E} , are given by the following formulas:

$$W_{AB}(\vec{F}) = q \cdot (V_A - V_B)$$

$V(A)-V(B)$ is the electrostatic potential difference between points A and B and is equal to:

$$V(A) - V(B) = \frac{W_{A \rightarrow B}}{q} = \frac{Q}{4\pi\epsilon_0} \left(\frac{1}{r_1} - \frac{1}{r_2} \right)$$

$$E_p(A) - E_p(B) = -\Delta E_p = W_{AB}$$

Special case:

If a point charge q is placed at the point M where there is an electric field and potential $\vec{E}(M)$ and $V(M)$, it will have a potential energy E_p given by:

$$E_p(q) = qV(M)$$

I.8. Electric dipole

The electric dipole is a system made up of two equal charges and opposite signs, $+q$ and $-q$, separated by a distance a . Every electric dipole is characterized by its **dipole moment** \vec{P} which is defined by:

$$\vec{P} = q \cdot \vec{a} \Rightarrow P = |q| \cdot a$$

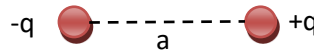

The vector \vec{a} is directed from the negative charge ($-q$) to the positive charge ($+q$).

I.8.1. Electric potential produced by an electric dipole:

We will calculate the electric potential produced by the two charges ($+q$) and ($-q$), at the point M located at the distance r_1 from the charge ($+q$) and at the distance r_2 from the charge ($-q$). The distance a is very small compared to the distances r_1 and r_2 .

The electrostatic potential V created in M by the two electric charges is equal to the sum of the potentials created by each charge taken separately:

$$V(M) = V(q_+) + V(q_-)$$

$$V(q_+) = \frac{1}{4\pi\epsilon_0} \frac{(+q)}{r_1}$$

$$V(q_-) = \frac{1}{4\pi\epsilon_0} \frac{(-q)}{r_2}$$

$$V(M) = V(q_+) + V(q_-) = \frac{1}{4\pi\epsilon_0} \frac{(+q)}{r_1} + \frac{1}{4\pi\epsilon_0} \frac{(-q)}{r_2}$$

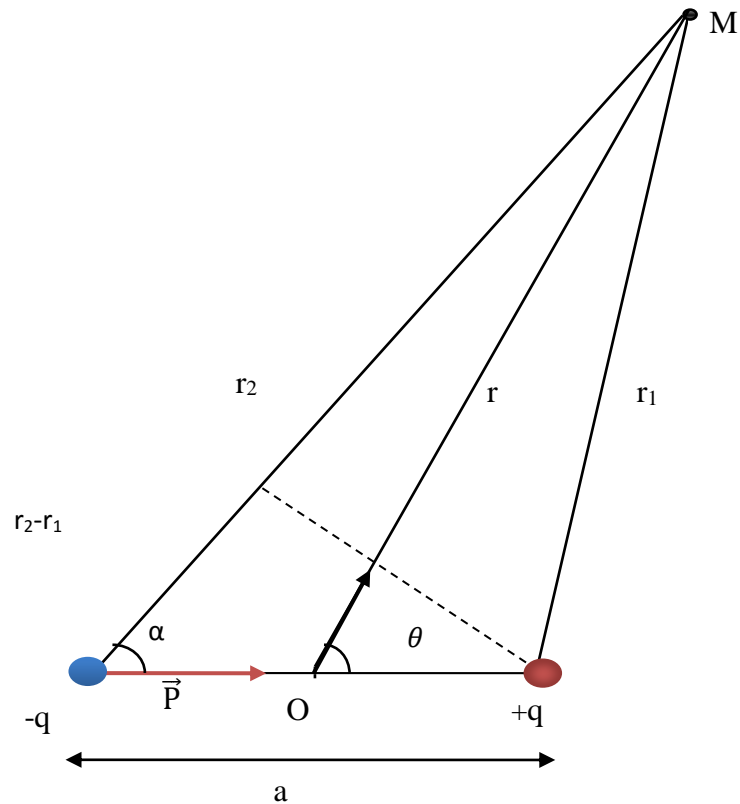

$$V(M) = \frac{q}{4\pi\epsilon_0} \frac{(r_2 - r_1)}{r_1 r_2}$$

We have:

$$a \ll r \Rightarrow r_1 + r_2 \approx 2r \text{ et } r_1 r_2 \approx r^2$$

$$r_2 - r_1 = a \cdot \cos \alpha$$

$$a \ll r \Rightarrow \alpha \approx \theta, \text{ So } : (r_2 - r_1) = a \cos \theta$$

$$V(M) = V(r, \theta) = \frac{q}{4\pi\epsilon_0} \frac{a \cdot \cos \theta}{r^2} = \frac{P \cos \theta}{4\pi\epsilon_0 r^2}$$

$$P = q \cdot a$$

Or,

$$V(M) = V(r, \theta) = \frac{1}{4\pi\epsilon_0} \frac{\vec{P} \cdot \vec{u}_r}{r^2}$$

I.8.2. Dipole Electrostatic Field

As V only depends on r and θ , we therefore calculate the components of the electric field in polar coordinates. Let be the polar reference frame with center O and base vectors $(\vec{u}_r, \vec{u}_\theta)$.

The electrostatic field vector \vec{E} at point M is written in polar coordinates:

$$\vec{E}(M) = E_r \vec{u}_r + E_\theta \vec{u}_\theta$$

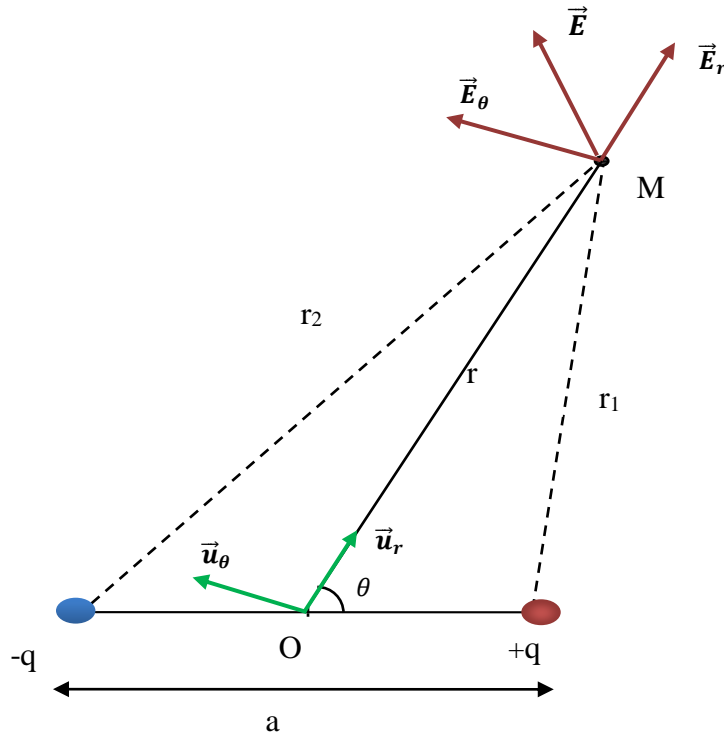

We also have $\vec{E}(M) = -\overrightarrow{grad}V(M)$

\overrightarrow{grad} in polar coordinates is written:

$$\overrightarrow{grad} = \begin{pmatrix} \frac{\partial}{\partial r} \\ \frac{1}{r} \cdot \frac{\partial}{\partial \theta} \end{pmatrix}$$

the radial E_r and tangential E_θ components are therefore :

$$\begin{cases} E_r = -\frac{\partial V}{\partial r} = \frac{1}{4\pi\epsilon_0} \frac{2P \cos \theta}{r^3} \\ E_\theta = -\frac{1}{r} \frac{\partial V}{\partial \theta} = \frac{1}{4\pi\epsilon_0} \frac{P \sin \theta}{r^3} \end{cases}$$

The module of the electric field vector is therefore

$$E = \sqrt{E_r^2 + E_\theta^2}$$

Either

$$E = \frac{1}{4\pi\epsilon_0} \frac{P}{r^3} \sqrt{4\cos^2\theta + \sin^2\theta}$$

$$E = \frac{1}{4\pi\epsilon_0} \frac{P}{r^3} \sqrt{3\cos^2\theta + 1}$$

I.8.3. Field lines equation:

The field line \vec{E} is collinear with $d\vec{l}$, so :

$$\vec{E} \parallel d\vec{l} \Rightarrow \vec{E} = C \cdot d\vec{l} \quad (c = cte)$$

$$\vec{E} \begin{pmatrix} E_r \\ E_\theta \end{pmatrix} \text{ and } d\vec{l} \begin{pmatrix} dr \\ r d\theta \end{pmatrix} \Rightarrow \frac{\vec{E}}{d\vec{l}} = C \Rightarrow \frac{dr}{E_r} = \frac{r d\theta}{E_\theta} \Rightarrow \frac{E_r d\theta}{E_\theta} = \frac{dr}{r}$$

$$\frac{\frac{2KP \cos \theta}{r^3} d\theta}{\frac{KP \sin \theta}{r^3}} = \frac{dr}{r} \Rightarrow \frac{2 \cos \theta}{\sin \theta} = \frac{dr}{r} \Rightarrow \frac{dr}{r} = \frac{2 d(\sin \theta)}{\sin \theta}$$

$$\int \frac{dr}{r} = 2 \int \frac{d(\sin \theta)}{\sin \theta} \Rightarrow \ln r = 2 \ln \sin \theta + c = \ln^2 \sin \theta + c \Rightarrow \ln \frac{r}{\sin^2 \theta} = c \Rightarrow \frac{r}{\sin^2 \theta} = c$$

The trajectory equation is

$$r = c \sin^2 \theta$$

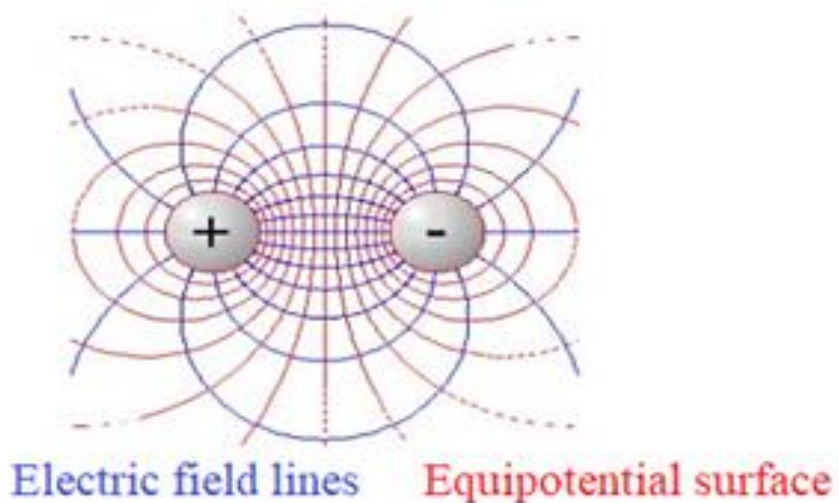

1.8.4. Potential energy of a dipole placed in a uniform external field \vec{E}_0 :

$$E_p = E_p(+q) + E_p(-q) = qV_B + (-q)V_A = q(V_B - V_A)$$

we know that : $dV = -\vec{E}_0 \cdot d\vec{l}$

$$\Rightarrow \int_{V_A}^{V_B} dV = -\vec{E}_0 \cdot \vec{a} \quad \left(\int d\vec{l} = \vec{a} \right)$$

$$\Rightarrow E_p = q \cdot (-\vec{E}_0 \cdot \vec{a}) = -q\vec{a} \cdot \vec{E}_0 = -\vec{P} \cdot \vec{E}_0$$

$$E_p = -\vec{p} \cdot \vec{E}_0 = -p \cdot E_0 \cdot \cos\theta$$

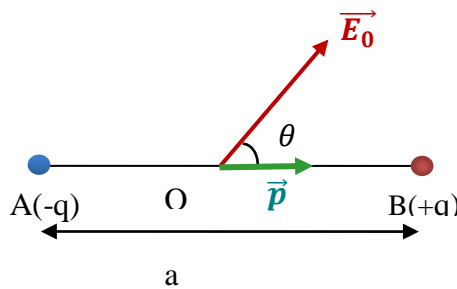

θ	E_p	
0	$-p \cdot E_0$	stable equilibrium
$\pm \frac{\pi}{2}$	0	
$\pm \pi$	$p \cdot E_0$	unstable equilibrium

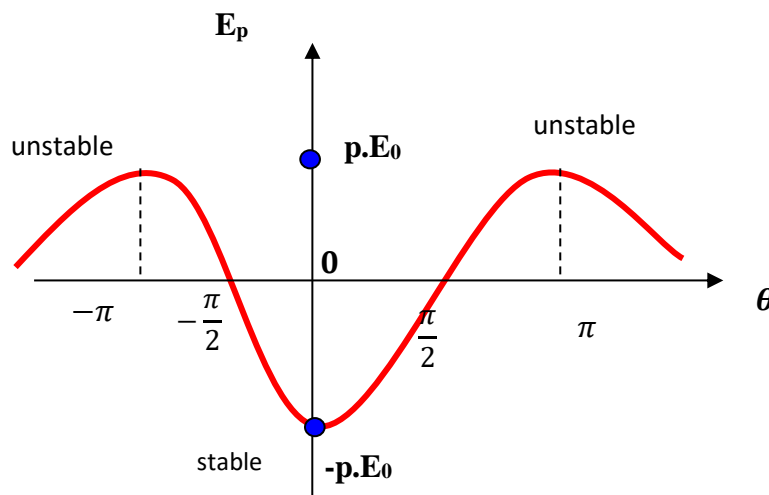

I.9. Electric field created by a distribution of charges

A continuous charge distribution is used to describe the charge of a macroscopic object . While the electric charge is an integer multiple of the unit of electric charge, it can be considered continuous. We can define three types of charge density, depending on the shape and dimensions of the object which creates the electric field:

Linear charge density λ :

It is defined as the charge density by unit of length.

This is the case with an electric wire.

$$\lambda = \frac{dq}{dl}$$

Surface charge density σ :

This is the charge density per unit area.

It is found in a flat body; For example a disk.

$$\sigma = \frac{dq}{ds}$$

Volume charge density ρ :

It is the charge density per unit volume.

It is used when the object has three dimensions;

Example: charged sphere.

$$\rho = \frac{dq}{dV}$$

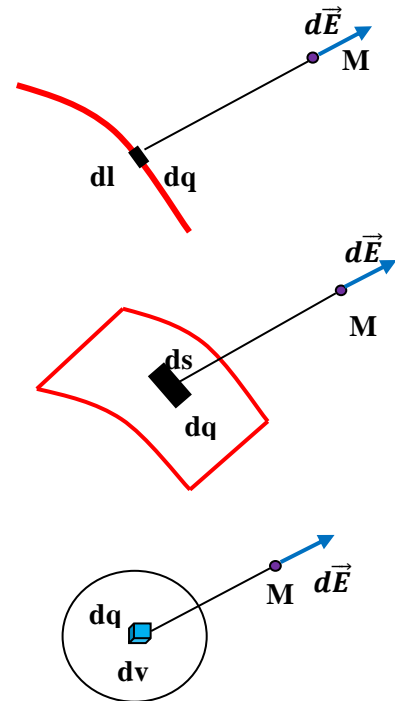

I.10. Gauss's theorem

Gauss' theorem allows us to quickly calculate the electric field \vec{E} created by symmetrical charge distributions. First, we must define the notions of the Solid Angle and the flow of the electric field through a surface.

I.10.1. Concept of solid angle

We saw in the previous study plane angles. But when it comes to spatial geometry we find the angle solid.

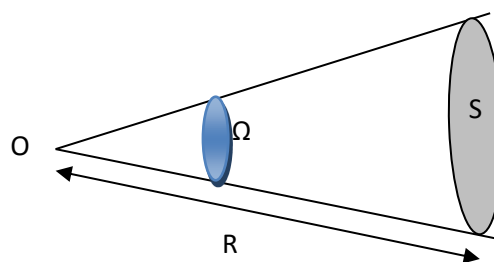

The solid angle is an "angle" in space, consider a sphere with center O and radius r.

We define the solid angle Ω under which we see a surface (S), from a point O, contained in a cone with vertex O.

$$d\Omega = \frac{d\vec{S} \cdot \vec{u}}{R^2} = \frac{dS \cdot \vec{n} \cdot \vec{u}}{R^2} = \frac{dS \cdot \cos\alpha}{R^2}$$

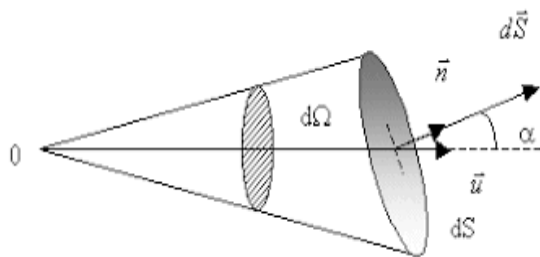

Remark:

If \vec{n} and \vec{u} are parallel, then $\cos \alpha = 1$, and therefore the solid angle is equal to:

$$d\Omega = \frac{dS}{R^2} \Rightarrow \Omega = \frac{S}{R^2}$$

I.10.2. Concept of the electric field through any surface

The flow of the field $\vec{E}(M)$ created at a point M by a charge distribution Q across a closed surface (S) is defined by

$$\Phi_S = \oiint_S \vec{E}(M) \cdot d\vec{S}(M)$$

With $d\vec{S}$ elementary surface vector: $d\vec{S} = dS \cdot \vec{n}$ and \vec{n} unit vector

I.10.3. Gauss's theorem

The field flux \vec{E} across a closed surface created by a charge distribution is equal to the algebraic sum of the charges present within that surface (S_G) divided by ϵ_0

$$\Phi_S = \oiint_S \vec{E}(M) \cdot d\vec{S}(M) = \frac{\sum Q_i}{\epsilon_0}$$

I.10.4. The relationship between solid angle and electric flux:

The electric field produced by a point charge

$$q \text{ at a distance from the load } E = \frac{kq}{r^2}$$

The flow through an elementary surface dS located at the distance r from the charge q is:

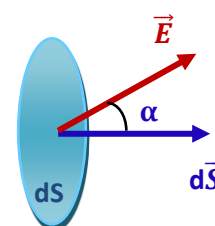

$$\Phi_S = \oiint_S \vec{E} \cdot d\vec{S} = \oiint_S K \frac{q}{r^2} dS \cdot \cos\alpha = \oiint_S Kq \, d\Omega$$

***General calculation method:**

- Find a closed surface passing through the point M where you want to calculate the field.
- Write the flow definition $\Phi_S = \oiint_S \vec{E} \cdot d\vec{S}$
- Apply Gauss' theorem after calculating the algebraic charge inside the surface.

Exercises

Exercise 1

We place respectively at points A, B and C the charges $q_1 = 1.5 \cdot 10^{-3} \text{ C}$, $q_2 = -0.5 \cdot 10^{-3} \text{ C}$ and $q_3 = 10^{-3} \text{ C}$. We give $AC = 1 \text{ m}$ and $BC = 0.5 \text{ m}$.

- Calculate the force exerted on the charge q_3 .

Exercise 2

We place at the vertices of a square ABCD of dimension $a = 1 \text{ cm}$ the charges $q_A = 2 \mu\text{C}$, $q_B = -4 \mu\text{C}$, $q_C = 2 \mu\text{C}$ and $q_D = 1 \mu\text{C}$.

- Calculate the field modulus at point O intersection of the diagonals.

Exercise 3

Consider a finished wire AB of length L and uniform positive linear charge λ .

1- Calculate the field vector \vec{E} and the potential V created by the fine wire AB at any point M located at distance x from the wire.

2 - Deduce \vec{E} and V when M is in the mediating plane of wire AB.

3- Deduce \vec{E} when the wire AB is of infinite length.

Exercise 4

1°) a) Determination of the field \vec{E}_M created by the disk at point M of the axis OX, located at a distance x from the center O of the disk.

b) Calculate the electric potential V created at point M.

2°) Let's check the relationship between the potential and the field: $\vec{E} = -\overrightarrow{\text{grad}}V$

3) Let us distinguish the field E when the radius of the disk R tends towards infinity.

Exercise 5

A wire, of infinite length, is uniformly charged by a positive linear density λ .

1)-By application of Gauss's Theorem calculate the electrostatic field created by this distribution at a point located at distance x from the wire.

Exercise 6

By using Gauss's theorem:

1- Calculate the electric field \vec{E} created at a point M located outside an infinite plane (P) of uniform surface charge density σ ($\sigma > 0$).

2- Deduce the field \vec{E} created in M by an infinite plane (P') perpendicular to (P) of uniform charge density 2σ .

3- Calculate the field \vec{E}_T resulting at this point.

Exercise 7

Consider two concentric spheres of radii R_1 and R_2 ($R_1 < R_2$). The outer sphere of radius R_2 is charged with a surface charge density σ constant and positive, as for the interior sphere of radius R_1 it is charged with a volume charge density ρ constant and positive.

Using Gauss's theorem, determine:

- 1- The electric field $E(r)$ at any point in space.
- 2- The electric potential $V(r)$ at any point in space.

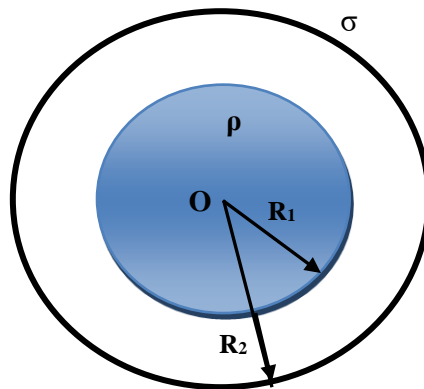

Exercise 8

We consider a uniformly charged ring with center O, radius R and positive linear charge λ .

- 1)- Calculate the field \vec{E}_{tot} and the potential V created at point M located on its axis OX such that $OM = x$
- 2)- Find the potential V using the relationship between the field and the potential.

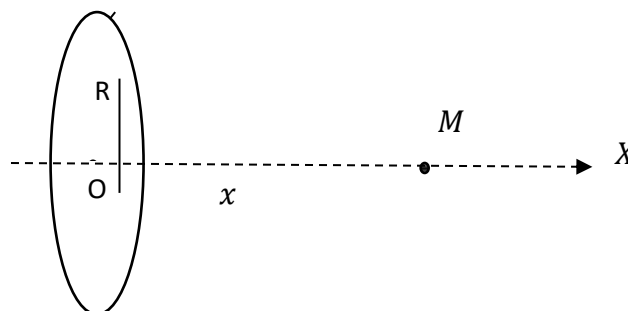

Solution

Exercise 1

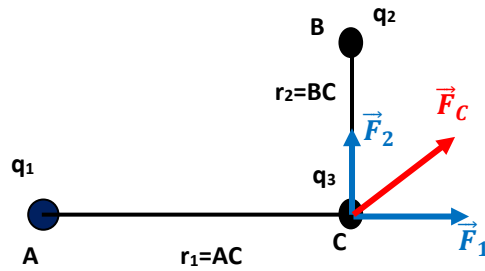

$$\vec{F}_C = \vec{F}_1 + \vec{F}_2 \Rightarrow |\vec{F}_C| = \sqrt{F_1^2 + F_2^2}$$

$$F_1 = K \frac{q_1 \cdot q_3}{r_1^2} \quad \text{Repulsion force (} q_1 > 0 \text{ and } q_3 > 0 \text{)}$$

$$F_2 = K \frac{q_2 \cdot q_3}{r_2^2} \quad \text{Force of attraction (} q_2 < 0 \text{ and } q_3 > 0 \text{)}$$

$$\text{AN: } F_1 = 9 \cdot 10^9 \frac{1.5 \cdot 10^{-3} \cdot 10^{-3}}{1^2} = 13.5 \cdot 10^3 \text{ N}$$

$$F_2 = 9 \cdot 10^9 \frac{0.5 \cdot 10^{-3} \cdot 10^{-3}}{(0.5)^2} = 18 \cdot 10^3 \text{ N}$$

$$\Rightarrow |\vec{F}_C| = \sqrt{(13.5 \cdot 10^3)^2 + (18 \cdot 10^3)^2} = 22.5 \cdot 10^3 \text{ N}$$

$|\vec{F}_C| = 22.5 \cdot 10^3 \text{ N}$

Exercise 2

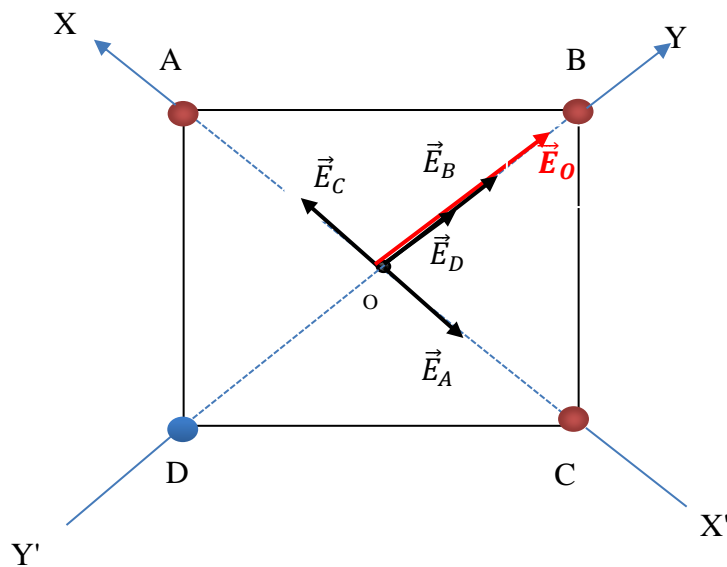

-Field module

$$\vec{E}_O = \vec{E}_A + \vec{E}_B + \vec{E}_C + \vec{E}_D$$

$$E_A = K \frac{q_A}{OA^2}$$

$$E_B = K \frac{q_B}{OB^2}$$

$$E_C = K \frac{q_C}{OC^2}$$

$$E_D = K \frac{q_D}{OD^2}$$

We have: $q_A = q_C$ and $q_B = 4q_D$ (in absolute value)

With: $OA = OB = OC = OD = a\sqrt{2}/2$

As the vectors are not straight, they must be projected on the axes (OX) and (OY)

$$\vec{E}_O = E_{Ox} \vec{i} + E_{Oy} \vec{j} \Rightarrow E_O = \sqrt{E_{Ox}^2 + E_{Oy}^2}$$

To simplify the calculations we choose the axes (OX) and (OY) coincident with the diagonals of the square

Projection along the OX axis

$$E_{Ox} = -E_A + E_C \Rightarrow E_{Ox} = -K \frac{q_A}{(a\sqrt{2}/2)^2} + K \frac{q_C}{(a\sqrt{2}/2)^2} = 0 \quad (E_A = E_C)$$

$$\boxed{E_{Ox} = 0}$$

Projection along the OY axis

$$E_{Oy} = E_B + E_D = K \frac{q_B}{(a\sqrt{2}/2)^2} + K \frac{q_D}{(a\sqrt{2}/2)^2} = \frac{2K}{a^2} (q_B + q_D)$$

$$\boxed{E_{Oy} = \frac{2K}{a^2} (q_B + q_D)}$$

$$\Rightarrow E_O = \sqrt{E_{Ox}^2 + E_{Oy}^2} = \sqrt{0 + E_{Oy}^2} = E_{Oy} = \frac{2K}{a^2} (q_B + q_D)$$

$$\boxed{\vec{E}_O = \vec{E}_{Oy} = \frac{2K}{a^2} (q_B + q_D) \vec{j}}$$

$$\vec{E}_O = 9.10^9 \frac{2(4 \times 10^{-6} + 1 \times 10^{-6})}{(10^{-2})^2} \vec{j} = 9.10^8 \vec{j}$$

$$\boxed{E_O = 9.10^8 \text{ V/m}}$$

Exercise 3

1.a- We take an elementary length dl which carries an elementary charge $dq = \lambda \cdot dl$, this charge creates an elementary field $d\vec{E}$ at point M, according to Coulomb's law

$$d\vec{E} = \frac{k \cdot dq}{r^2} \vec{u} = \frac{1}{4\pi\epsilon_0} \frac{\lambda dl}{r^2} \vec{u} \Rightarrow E = \frac{1}{4\pi\epsilon_0} \frac{\lambda dl}{r^2}$$

here r is the distance between the charge dq and the point M .

Let's project the vector $d\vec{E}$ onto the ox and oy axes.

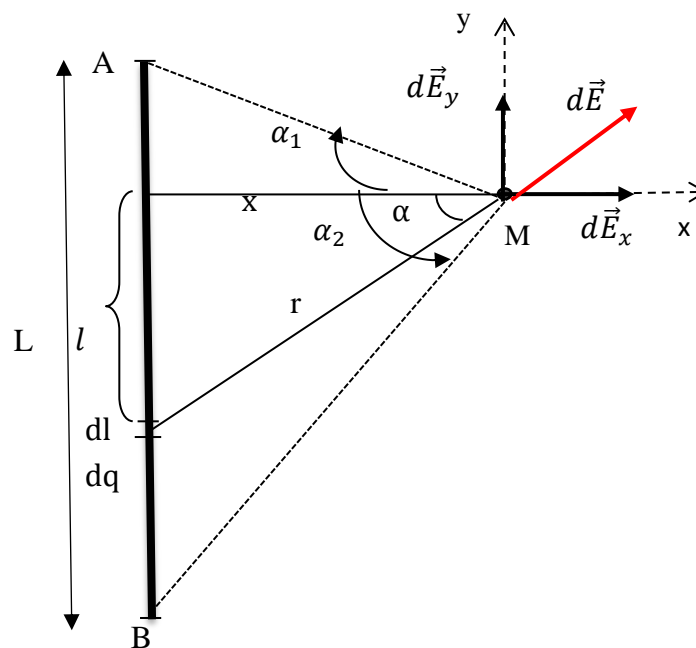

$$d\vec{E} = d\vec{E}_x + d\vec{E}_y \quad \text{or} \quad \begin{cases} d\vec{E}_x = dE_x \vec{i} \\ d\vec{E}_y = dE_y \vec{j} \end{cases}$$

$$\vec{E} = E_x \vec{i} + E_y \vec{j}$$

$$\Rightarrow E = \sqrt{E_x^2 + E_y^2}$$

Projection on the ox axis

$$dE_x = dE \cos \alpha = \frac{1}{4\pi\epsilon_0} \frac{\lambda dl}{r^2} \cos \alpha$$

Projection on the oy axis

$$dE_y = dE \sin \alpha = \frac{1}{4\pi\epsilon_0} \frac{\lambda dl}{r^2} \sin \alpha$$

The components dE_x and dE_y are a function of three variables dl, α et r . Let's express them according to of a single variable, α for example.

$$\tan \alpha = \frac{l}{x} \Rightarrow l = x \tan \alpha \Rightarrow dl = \frac{x d\alpha}{\cos^2 \alpha}$$

$$\text{And } \cos \alpha = \frac{x}{r} \Rightarrow r = x \cos \alpha$$

Let us replace dl and r in the expressions of dE_x and dE_y :

$$dE_x = \frac{\lambda}{4\pi\epsilon_0 x} \cos \alpha d\alpha \quad \text{and} \quad dE_y = \frac{\lambda}{4\pi\epsilon_0 x} \sin \alpha d\alpha$$

Calculation of E_x :

$$E_x = \int dE_x = \frac{\lambda}{4\pi\epsilon_0 x} \int_{-\alpha_2}^{\alpha_1} \cos \alpha d\alpha = \frac{\lambda}{4\pi\epsilon_0 x} \sin \alpha \Big|_{-\alpha_2}^{\alpha_1}$$

$$E_x = \frac{\lambda}{4\pi\epsilon_0 x} (\sin \alpha_1 + \sin \alpha_2)$$

Calculation of E_y :

$$E_y = \int dE_y = \frac{\lambda}{4\pi\epsilon_0 x} \int_{-\alpha_2}^{\alpha_1} \sin \alpha d\alpha = -\frac{\lambda}{4\pi\epsilon_0 x} \cos \alpha \Big|_{-\alpha_2}^{\alpha_1}$$

$$E_y = \frac{\lambda}{4\pi\epsilon_0 x} (\cos \alpha_2 - \cos \alpha_1)$$

$$E = \sqrt{E_x^2 + E_y^2}$$

$$E = \frac{\lambda}{4\pi\epsilon_0 x} \sqrt{(\sin \alpha_1 + \sin \alpha_2)^2 + (\cos \alpha_2 - \cos \alpha_1)^2} = \frac{\lambda}{4\pi\epsilon_0 x} \sqrt{2 - 2(\sin \alpha_1 \sin \alpha_2 - \cos \alpha_1 \cos \alpha_2)}$$

$$E = \frac{\lambda}{4\pi\epsilon_0 x} \sqrt{2(1 - \cos(\alpha_1 + \alpha_2))} = \frac{\lambda}{4\pi\epsilon_0 x} \sqrt{4 \sin^2 \frac{(\alpha_1 + \alpha_2)}{2}}$$

$$E = \frac{2 \cdot \lambda}{4\pi\epsilon_0 x} \sin \frac{(\alpha_1 + \alpha_2)}{2}$$

1.b- Calculation of potential :

$$dV = \frac{kdq}{r} = \frac{\lambda dl}{4\pi\epsilon_0 r} = \frac{\lambda dl}{4\pi\epsilon_0 (x^2 + l^2)^{1/2}}$$

$$V = \int dV = \frac{\lambda}{4\pi\epsilon_0} \int_0^L \frac{dl}{(x^2 + l^2)^{1/2}} \frac{\lambda}{4\pi\epsilon_0} \ln \left(l + \sqrt{x^2 + l^2} \right) \Big|_0^L$$

$$V = \frac{\lambda}{4\pi\epsilon_0} \left[\ln \left(L + \sqrt{x^2 + L^2} \right) - \ln(x) \right] = \frac{\lambda}{4\pi\epsilon_0} \ln \frac{L + \sqrt{x^2 + L^2}}{x}$$

2.a - Deduce \vec{E} and V when M is in the mediating plane of wire AB:

To do this, simply take: $\alpha_1 = \alpha_2$

$$E = \frac{2K\lambda}{x} \sin \alpha_1 = \frac{2K\lambda}{x} \left(\frac{L/2}{r} \right) = \frac{K\lambda L}{x \sqrt{x^2 + \frac{L^2}{4}}}$$

$$E = \frac{2K\lambda L}{x \sqrt{4x^2 + L^2}}$$

Another method which consists of associating the elements $d\ell$ in pairs so that the components normal to Oy of the corresponding fields compensate for each other (reasons of symmetry with respect to Oy); only the components are added $dE_x = dE \cos \alpha$

$$\text{for } \alpha_1 = \alpha_2, \quad E_x = \frac{K\lambda}{x} (\sin \alpha_1 + \sin \alpha_1) = \frac{K\lambda}{x} (2 \sin \alpha_1)$$

$$\sin \alpha_1 = \frac{L/2}{r} \quad \text{so} \quad E_x = \frac{2K\lambda}{x} \left(\frac{L}{\sqrt{4x^2 + L^2}} \right)$$

$$E = E_x = \frac{2K\lambda L}{x \sqrt{4x^2 + L^2}}$$

2.b - Deduce the potential V created at point M which is located in the mediating plane of wire AB:

$$\text{We have } dV = \frac{K dq}{r} = \frac{K \lambda dl}{r} = \frac{K \lambda dl}{\sqrt{x^2 + l^2}}$$

$$\Rightarrow V = K\lambda \int_{-\frac{L}{2}}^{\frac{L}{2}} \frac{dl}{\sqrt{x^2 + l^2}} = K\lambda \cdot \ln \left[l + \sqrt{l^2 + x^2} \right]_{-\frac{L}{2}}^{\frac{L}{2}}$$

$$\Rightarrow V = K\lambda \cdot \ln \left(\frac{L + \sqrt{L^2 + 4x^2}}{-L + \sqrt{L^2 + 4x^2}} \right)$$

3- Deduce \vec{E} when the wire AB is of infinite length:

When the wire AB is of infinite length, this results in : $\alpha_1 = \alpha_2 = \pi/2$

$$E = \frac{2K \lambda}{x} \sin\left(\frac{\pi/2 + \pi/2}{2}\right) = \frac{2K \lambda}{x} \sin \frac{\pi}{2}$$

$$\boxed{E = \frac{2 K \lambda}{x}}$$

Exercise 4

1° a) Determination of the field \vec{E}_M created by the disk at point M of the axis OX, located at a distance x from the center O of the disk:

For reasons of symmetry with respect to the Ox axis, the component $E_{M_y}=0$, therefore the field \vec{E}_M will only admit the component \vec{E}_{M_x} , either :

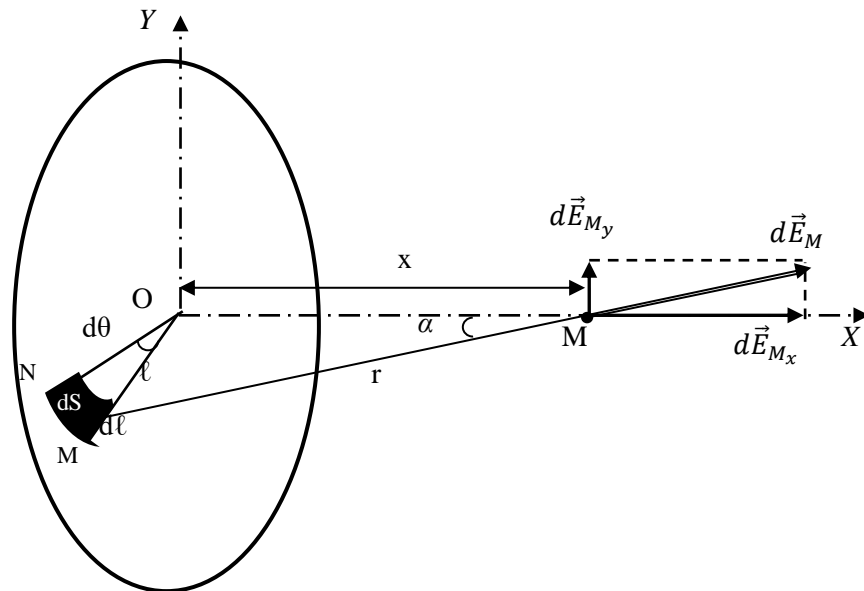

$$dE_{M_x} = dE_M \cos \alpha$$

The elementary field $d\vec{E}_M$ due to an element of surface dS of charge $dq = \sigma dS$, has the expression:

$$dE_M = \frac{K dq}{r^2} = \frac{K \sigma dS}{r^2}$$

We will therefore write :

$$dE_{M_x} = K\sigma \frac{dS}{r^2} \cos \alpha$$

$$\text{Or : } dS = \widehat{MN}d\ell = \ell d\theta d\ell$$

$$\text{And } \cos \alpha = \frac{x}{r} = \frac{x}{\sqrt{x^2 + \ell^2}}$$

$$\text{SO : } dE_{M_x} = K\sigma \frac{\ell d\theta d\ell}{x^2 + \ell^2} \cdot \frac{x}{\sqrt{x^2 + \ell^2}} = K\sigma x \left(\frac{d\theta \ell d\ell}{(x^2 + \ell^2)^{3/2}} \right)$$

$$E_{M_x} = K\sigma x \int_0^{2\pi} d\theta \int_0^R \frac{\ell d\ell}{(x^2 + \ell^2)^{3/2}} = K\sigma x 2\pi \left[-\frac{1}{\sqrt{x^2 + \ell^2}} \right]_0^R$$

$$\boxed{E_M = E_{M_x} = 2\pi K\sigma \left(1 - \frac{x}{\sqrt{x^2 + R^2}} \right)}$$

b) Calculate the electric potential V created at point M:

$$dV = \frac{K dq}{r} = \frac{K \sigma dS}{r} = \frac{K \sigma \ell d\theta d\ell}{\sqrt{x^2 + \ell^2}}$$

$$V = K\sigma \int_0^{2\pi} d\theta \int_0^R \frac{\ell d\ell}{\sqrt{x^2 + \ell^2}} = 2\pi K\sigma \left[\sqrt{x^2 + \ell^2} \right]_0^R$$

$$\boxed{V = 2\pi K\sigma \left(\sqrt{x^2 + R^2} - x \right)}$$

2°) Let's check the relationship between the potential and the field: $\vec{E} = -\overrightarrow{\text{grad}V}$

$$E_M = -\frac{dV}{dx} = -2\pi K\sigma \left(\frac{2x}{2\sqrt{x^2 + R^2}} - 1 \right) = 2\pi K\sigma \left(1 - \frac{x}{\sqrt{x^2 + R^2}} \right)$$

$$\boxed{E_M = 2\pi K\sigma \left(1 - \frac{x}{\sqrt{x^2 + R^2}} \right)}$$

We find the same result as that of question 1, the relationship $\vec{E} = -\overrightarrow{\text{grad}V}$ is verified.

3) Let us distinguish the field E when the radius of the disk R tends towards infinity

$$\text{When } R \rightarrow \infty \Rightarrow E_M = 2\pi K\sigma \left(1 - \frac{x}{\sqrt{x^2 + R^2}} \right) = 2\pi K\sigma (1 - 0) = 2\pi K\sigma$$

$$\boxed{E_M = 2\pi K\sigma}$$

It is the field of an infinite plane uniformly charged at a surface density $\sigma > 0$

Exercise 5

A wire, of infinite length, is uniformly charged by a positive linear density λ .

1)-By application of Gauss's Theorem calculate the electrostatic field created by this distribution at a point located at distance x from the wire.

1)- Let us take as a closed surface (Gaussian surface) , a cylinder of radius x and length l and axis the infinite wire.

For reasons of symmetry the field \vec{E} is radial (carried by ox).

The flux of the vector \vec{E} leaving the closed surface is

$$\phi(\vec{E}) = \phi_{S_1}(\vec{E}) + \phi_{S_2}(\vec{E}) + \phi_{S_3}(\vec{E}).$$

$$\phi(\vec{E}) = \iint_{S_1} \vec{E} \cdot d\vec{S}_1 + \iint_{S_2} \vec{E} \cdot d\vec{S}_2 + \iint_{S_3} \vec{E} \cdot d\vec{S}_3$$

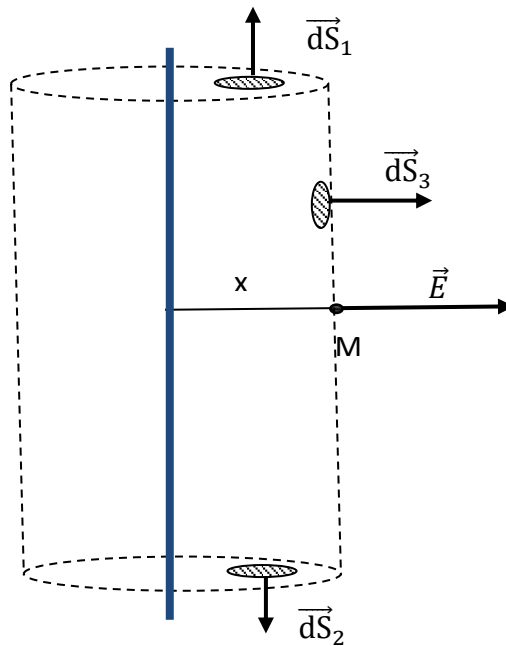

The field \vec{E} is perpendicular to the normal at any point on both basis \vec{S}_1 and \vec{S}_2 therefore

$$\vec{E} \cdot d\vec{S}_1 = \vec{E} \cdot d\vec{S}_2 = 0$$

$$\Rightarrow \phi_{S_1}(\vec{E}) = \phi_{S_2}(\vec{E}) = 0$$

Also, the field \vec{E} is parallel to the normal of the lateral surface $^2\vec{S}_3$

$$\phi_{S_3}(\vec{E}) = \iint_{S_3} E \cdot dS_3 = E \cdot S_3 = E2\pi xl$$

2)-The total charge contained in the *Gaussian surface* is.

$$Q = \int dq = \lambda \int dl = \lambda l$$

Gauss 's theorem

$$E2\pi xl = \frac{\lambda l}{\epsilon_0}$$

$$E = \frac{\lambda}{2\pi x \epsilon_0}$$

Exercise 6

1)-Let us take as a *Gaussian surface* a cylinder with an axis perpendicular to the plane. By reason of symmetry the field \vec{E} is perpendicular to the plane (P)

The flux of the vector \vec{E} leaving the *Gaussian surface* is

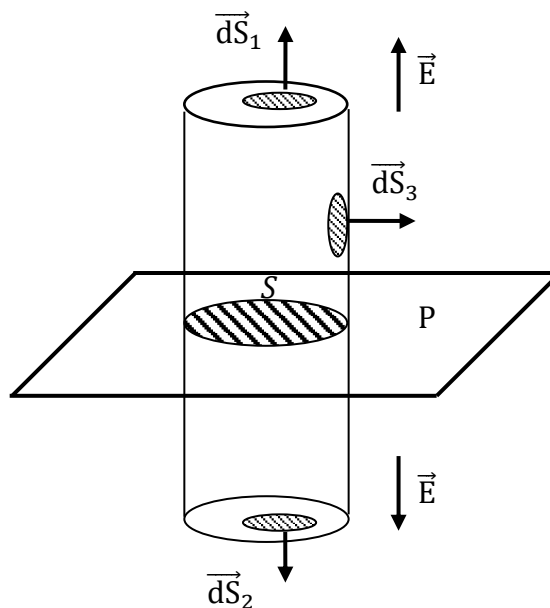

$$\Phi(\vec{E}) = \Phi_{S_1}(\vec{E}) + \Phi_{S_2}(\vec{E}) + \Phi_{S_3}(\vec{E})$$

$$\Phi(\vec{E}) = \iint_{S_1} \vec{E} \cdot d\vec{S}_1 + \iint_{S_2} \vec{E} \cdot d\vec{S}_2 + \iint_{S_3} \vec{E} \cdot d\vec{S}_3$$

The field \vec{E} is perpendicular to the normal of the side surface $\vec{S}_3 \Rightarrow \Phi_{S_3} = 0$

On the other hand, we have everything from the two bases S_1 and S_2 the field \vec{E} is parallel to the normal so

$$\Phi(\vec{E}) = \Phi_{S_1} + \Phi_{S_2} = ES_1 + ES_2 = 2ES_1 = 2ES \quad (S_1 = S_2 = S)$$

The charge contained in the *Gaussian surface* is

$$Q = \iint_S dq = \sigma \iint_S dS = \sigma S \text{ with } S = S_1 = S_2$$

We apply Gauss' theorem:

$$\phi(\vec{E}) = 2ES = \frac{\sigma S}{\epsilon_0}$$

$$\boxed{E = \frac{\sigma}{2\epsilon_0}}$$

2)-By analogy with question 1, the field \vec{E}' created by the plane (P') is

$$\boxed{E' = \frac{\sigma}{\epsilon_0}}$$

The resulting field \vec{E} is then $\vec{E}_{total} = \vec{E} + \vec{E}'$

$$E_{total} = \sqrt{E^2 + E'^2} = \sqrt{\left(\frac{\sigma}{2\epsilon_0}\right)^2 + \left(\frac{\sigma}{\epsilon_0}\right)^2} = \frac{\sqrt{5}\sigma}{2\epsilon_0} \Rightarrow E_{tot} = \frac{\sqrt{5}\sigma}{2\epsilon_0}$$

$$\boxed{E_{tot} = \frac{\sqrt{5}\sigma}{2\epsilon_0}}$$

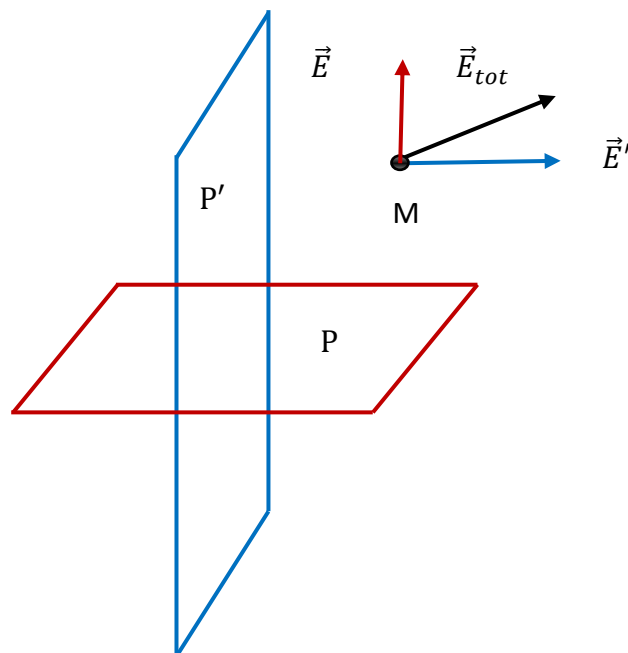

Exercise 7

Given the symmetry of the problem, the field is radial.

❖ 1st case : $r < R_1$

The flux Φ leaving the Gaussian sphere is:

$$\Phi = E_1(r) S_G = E_1(r) 4\pi r^2 \quad (S_G = S_{Gauss})$$

The internal charge of the Gaussian sphere is:

$$\sum q_{int} = \int_0^r \rho dV = \int_0^r \rho \cdot 4\pi r^2 dr = \frac{4\rho \pi r^3}{3}$$

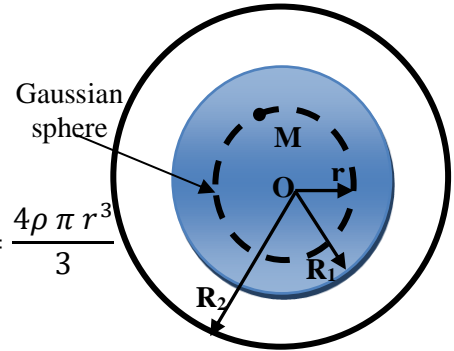

We will therefore have:

$$\Phi = E_1 \cdot S = \frac{\sum q_{int}}{\epsilon_0} \Rightarrow E_1 4\pi r^2 = \frac{\rho 4\pi r^3}{3\epsilon_0}$$

$$E_1 = \frac{\rho r}{3\epsilon_0}$$

b) 2nd case : $R_1 < r < R_2$

$$\Phi = E_2(r) S_G = E_2(r) 4\pi r^2$$

The internal charge of the Gaussian sphere is:

$$\sum q_{int} = \int_0^{R_1} \rho dV = \int_0^{R_1} \rho \cdot 4\pi r^2 dr = \frac{4\rho \pi R_1^3}{3}$$

He comes :

$$\Phi = E_2 \cdot S = \frac{\sum q_{int}}{\epsilon_0} \Rightarrow E_2 4\pi r^2 = \frac{\rho 4\pi R_1^3}{3\epsilon_0}$$

$$E_2 = \frac{\rho R_1^3}{3\epsilon_0 r^2}$$

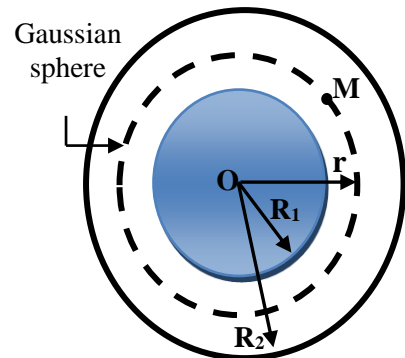

c) 3rd case : $r > R_2$

$$\Phi = E_3(r) S_G = E_3(r) 4\pi r^2.$$

The internal charge of the Gaussian sphere is:

$$\sum q_{int} = q_{R_1} + q_{R_2} = \frac{4\rho \pi R_1^3}{3} + \int_0^{R_2} \sigma dS$$

$$\sum q_{int} = \frac{4\rho \pi R_1^3}{3} + \sigma \int_0^{R_2} 8\pi r dr = \frac{4\rho \pi R_1^3}{3} + 4\pi\sigma R_2^2$$

Eventually :

$$E_3(r)4\pi r^2 = \frac{4\rho \pi R_1^3}{3\varepsilon_0} + \frac{4\pi\sigma R_2^2}{\varepsilon_0}$$

$$E_3(r) = \frac{\rho R_1^3 + 3\sigma R_2^2}{3 \varepsilon_0 r^2}$$

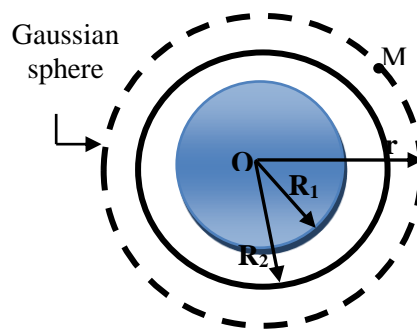

Exercise 8

1)- The field created by an elementary charge dq is:

$$d\vec{E} = \frac{1}{4\pi\varepsilon_0} \frac{\lambda dl}{r^2} \vec{u}$$

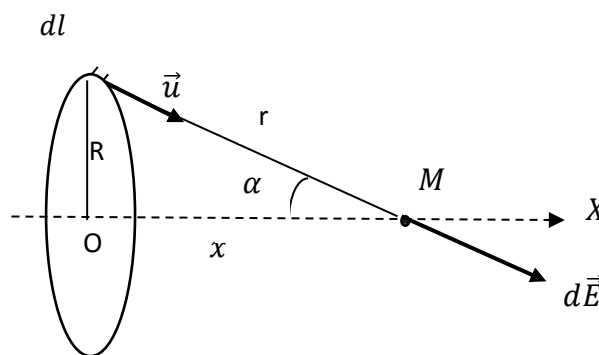

For reasons of symmetry the total electric field is carried by ox ,

$$\vec{E}_{tot} = \vec{E}_x$$

$$E_{tot} = \int dE_x$$

$$dE_x = \frac{1}{4\pi\epsilon_0} \frac{\lambda dl}{r^2} \cos \alpha,$$

We have

$$\cos \alpha = \frac{x}{r} = \frac{x}{\sqrt{x^2 + R^2}}$$

$$E_{tot} = \frac{1}{4\pi\epsilon_0} \frac{\lambda x}{(x^2 + R^2)^{3/2}} \int_0^{2\pi R} dl$$

$$E_{tot} = \frac{\lambda x R}{2\epsilon_0 (x^2 + R^2)^{3/2}}.$$

- potential V

$$dV = \frac{1}{4\pi\epsilon_0} \frac{\lambda dl}{r} =$$

$$V = \frac{1}{4\pi\epsilon_0} \frac{\lambda x}{(x^2 + R^2)^{1/2}} \int_0^{2\pi R} dl$$

$$V = \frac{\lambda R}{2\epsilon_0 (x^2 + R^2)^{1/2}}.$$

2)-We can deduce the potential by the relation

$$\vec{E} = -\overrightarrow{\text{grad}}V$$

$$E = -\frac{dV}{dx} \Rightarrow dV = -Edx$$

$$V = -\frac{\lambda R}{2\epsilon_0} \int \frac{x}{(x^2 + R^2)^{3/2}} dx$$

$$V = \frac{\lambda R}{2\epsilon_0} \frac{x}{(x^2 + R^2)^{1/2}} + c$$

$$V(\infty) = 0 \Rightarrow c = 0 \Rightarrow V = \frac{\lambda R}{2\epsilon_0} \frac{x}{(x^2 + R^2)^{1/2}}.$$

Chapter 2

Conductors

Michael Faraday

- 1791 – 1867
- British physicist and chemist
- Great experimental scientist
- Contributions to early electricity include:
 - Invention of motor, generator, and transformer
 - Electromagnetic induction
 - Laws of electrolysis



II.1. Classification of materials

We have two types of materials: conductors and insulators

a. Conductor materials

In conductors, electrical charges are free to move and are distributed throughout the material. An electrical conductor therefore conducts electric current.

b. Insulating materials (dielectrics)

Conversely, an electrical insulator is a medium that does not conduct electric current, because it does not allow the passage of free electrons from one atom to another.

II.2. Definition

- ❖ A conductor is a body inside which charges can move (mobile charges) under the action of an electric field or force.
- ❖ A conductor is said to be in electrostatic equilibrium if its charges inside are immobile, (the charges are not subject to any force).

II.3. Properties of a conductor in electrostatic

a- The electrostatic field inside a conductor in equilibrium is zero:

Since the charges inside the conductor in equilibrium are immobile, therefore the force acting on the charges is zero, which means that the electric field inside the conductor is also zero.

$$\vec{F} = q\vec{E} = \vec{0} \Rightarrow \vec{E} = \vec{0}$$

b- The conductor in equilibrium constitutes an equipotential volume:

Inside the driver $\vec{E} = \vec{0}$, and we also have:

$$\vec{E} = -\overrightarrow{\text{grad}}V = \vec{0} \Rightarrow V = \text{cte}$$

We deduce that the electrostatic potential at any point of a conductor in equilibrium is constant, therefore the conductor in electrostatic equilibrium comprises an equipotential volume.

As a result, the outer surface of the conductor is an equipotential surface, which proves that the field is perpendicular to the surface of the conductor.

$$V_A - V_B = \int \vec{E} \cdot d\vec{l} = 0 \Rightarrow \vec{E} \perp d\vec{l}$$

c- The conductor's charge is distributed over its surface:

Inside the conductor $\vec{E} = \vec{0}$, according to Gauss' theorem the flow is therefore zero through any closed surface inside the conductor

$$\phi = \oiint_S \vec{E} \cdot d\vec{S} = \frac{\sum Q_{int}}{\epsilon_0} = 0 \Rightarrow \sum Q_{int} = 0$$

$$\sum Q_{int} = 0 \Rightarrow \rho = 0$$

Since the number of protons is equal to the number of electrons, the total charge inside the conductor is zero. All free charges are distributed over the surface.

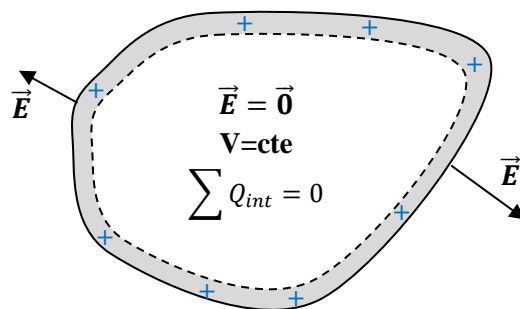

Remark

The same properties are valid for a hollow conductor.

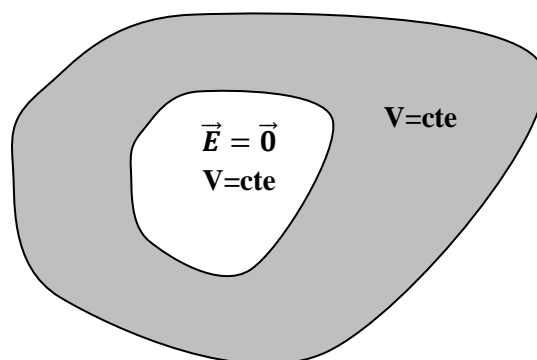

II.4. Field in the vicinity of a conductor in equilibrium: Coulomb's theorem

Let us calculate the electric field in the vicinity of the external surface of the conductor. By applying Gauss's theorem to a cylindrical Gaussian surface, one base of which is outside the surface (S_1) and the other base inside the conductor ($q=0$) (S_2)

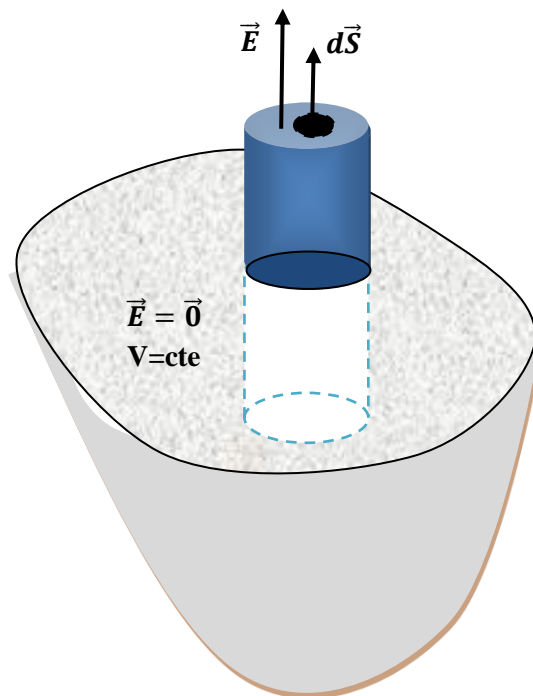

$$\Phi = \oiint_{S_1} \vec{E} \cdot d\vec{S}_1 + \oiint_{S_2} \vec{E} \cdot d\vec{S}_2 + \oiint_{S_{lat}} \vec{E} \cdot d\vec{S}_{lat} = ES$$

$$\boxed{\Phi = ES}$$

- The flow through the interior base (S_2) is zero ($E=0$)

- The flow through the lateral surface (S_{lat}) is zero $\vec{E} \perp \vec{dS}$

($S_1=S_2=S$)

$$\Phi = ES = \frac{\sum Q_i}{\epsilon_0} = \frac{\iint_S \sigma dS}{\epsilon_0} = \frac{\sigma S}{\epsilon_0}$$

$$\boxed{E = \frac{\sigma}{\epsilon_0}}$$

Remark

We found the value of the electric field at a point close to the outer surface of the conductor, and the field inside is zero.

On the surface of the conductor the field takes an average value:

$$E_m = \frac{E_{ext} + E_{int}}{2} = \frac{\frac{\sigma}{\epsilon_0} + 0}{2} = \frac{\sigma}{2\epsilon_0}$$

$$E_m = \frac{\sigma}{2\epsilon_0}$$

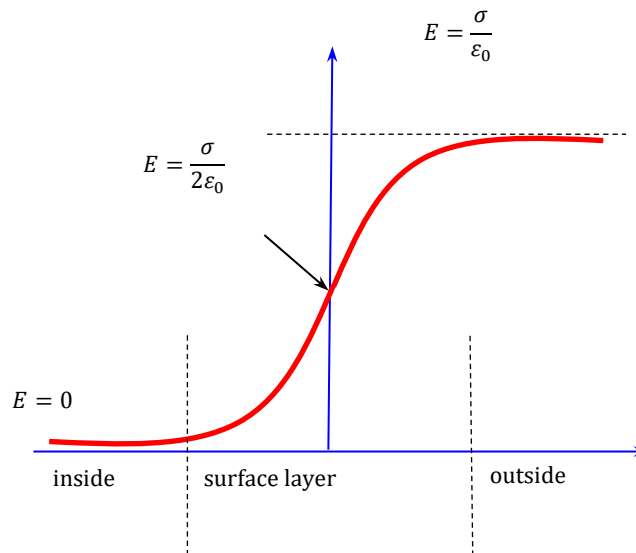
**II.4. Electrostatic pressure**

Electrostatic pressure is the force exerted per unit area. Charges on the surface of a conductor are subject to repulsive forces from other charges:

$$F = dqE_m = \sigma dS \cdot \frac{\sigma}{2\epsilon_0} = \frac{\sigma^2}{2\epsilon_0} dS$$

We can therefore calculate the electrostatic pressure:

$$P = \frac{dF}{dS} = \frac{\frac{\sigma^2 dS}{2\epsilon_0}}{dS} = \frac{\sigma^2}{2\epsilon_0}$$

$$P = \frac{\sigma^2}{2\epsilon_0}$$

II.5. Peak effect: Distribution of charges on a

Near a tip, the electrostatic field is very intense. This means that the surface density of charges is very high in the vicinity of a tip.

Consider two conducting spheres with respective radii R_1 and R_2 ($R_1 > R_2$) carried to the same potential (connected by a conducting wire). The two spheres have uniform charge density σ_1 and σ_2 .

$$V_1 = V_2 = \frac{kq_1}{R_1} = \frac{kq_2}{R_2} \Rightarrow \frac{k\sigma_1 S_1}{R_1} = \frac{k\sigma_2 S_2}{R_2} \Rightarrow \sigma_1 R_1 = \sigma_2 R_2$$

$$\boxed{\frac{\sigma_1}{\sigma_2} = \frac{R_2}{R_1}}$$

So, the smaller one of the spheres will have a radius, the more its charge density will be high.

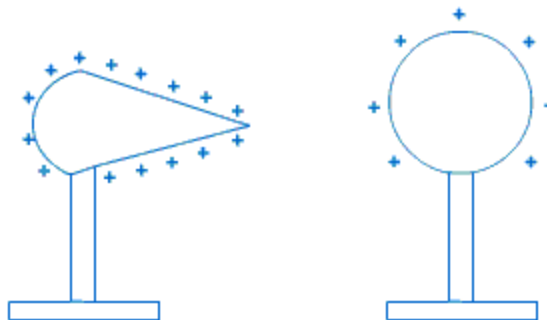
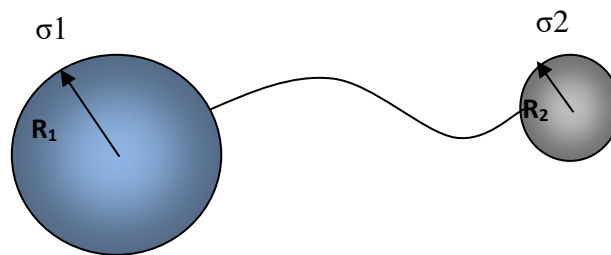

II.6. Capacity of a driver isolated

The electrostatic capacitance of a conductor at equilibrium is defined by

$$C = \frac{Q}{V}$$

where Q is the total electric charge of the conductor brought to potential V .

The unit of capacitance is the Farad (symbol F).

Example:

Capacity of a spherical conductor (radius R) of charge Q .

$$C = \frac{Q}{V}$$

At any point on the surface $V = \frac{kQ}{R}$

$$C = \frac{Q}{V} = \frac{Q}{\frac{kQ}{R}} = 4\pi\epsilon_0 R$$

- For the earth $R = 6400$ km, $C = 710 \mu\text{F}$ (The microfarad : $1 \mu\text{F} = 10^{-6} \text{F}$)

Generalization

We can generalize the notion of capacitance to a set of conductors. In the case of two conductors carrying two charges $+Q$ and $-Q$, including the potential difference between them:

$U = V_1 - V_2$, the capacitance of the system is:

$$C = \frac{Q}{V_1 - V_2} = \frac{Q}{U}$$

II.7. Internal energy of an isolated charged conductor

Let Q be the charge of the conductor and C its capacitance and V its potential in the equilibrium state. Its internal energy is measured by the work required to charge the conductor either :

$$E_p = \frac{1}{2} QV = \frac{1}{2} CV^2 = \frac{1}{2} \frac{Q^2}{C}$$

II.8. phenomena between charged conductors**II.8.1. Partial influence (Influence suffered by an insulated conductor)**

Consider two conductors A neutral ($Q_+ = Q_-$ therefore $Q_{\text{total}} = 0$) and B charged (Q_+). Let us approach body B from A. The latter creates an electric field E_B in conductor A. The free electrons of conductor A will, under the action of E_B , move in the opposite direction to E_B . Conversely, positive charges will appear on the other side due to lack of electrons. We say that conductor A is influenced by B.

The influence phenomenon does not modify the total charge of an insulated conductor, but only modifies the distribution of this charge on its surface and therefore its potential.

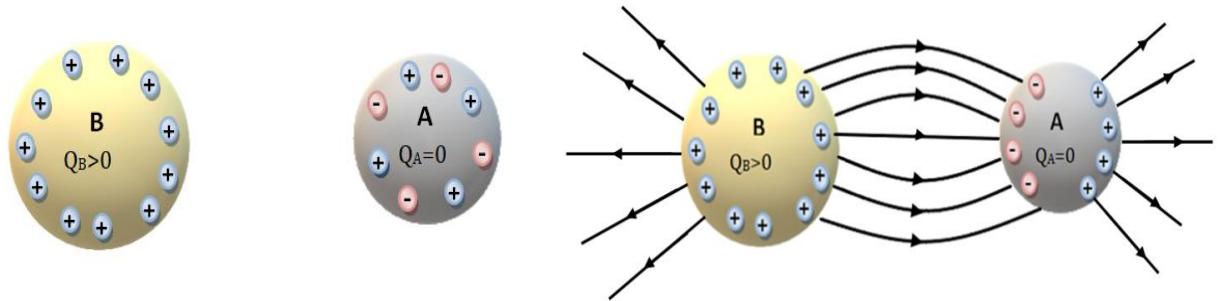

Special cases:

We take the previous example of partial influence and connect conductor A to earth (ground), using a conductive wire; the earth and conductor A form a new conductor; the positive charges are then repelled towards the earth. The potential of this conductor is zero $V_A = 0$ and no more field lines leave it.

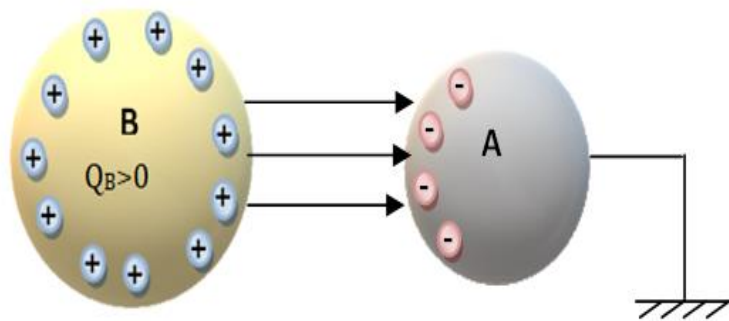

II.8.2. Total influence

We say that there is total influence if B completely surrounds A; all field lines starting from A arrive at B.

We notice that the charge, which appears on the internal surface of B, is equal and opposite to the charge of conductor A:

$$Q_{Bint} = - Q_A$$

The charge that appears on the external surface of B is equal to the charge of conductor A:

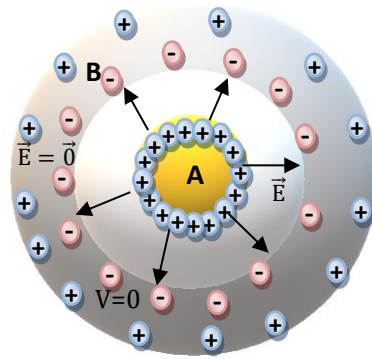

$$Q_{\text{Bext}} = Q_A$$

$$Q_B = Q_{\text{Bint}} + Q_{\text{Bext}} = -Q_A + Q_A = 0$$

Special cases:

1- B isolated and has an initial charge Q' , then

$$Q_B = Q_{\text{Bint}} + Q_{\text{Bext}} = -Q_A + (Q_A + Q') = Q'$$

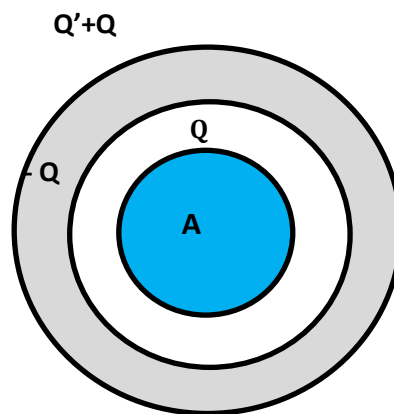

2- B connected to the ground

$$Q_B = Q_{\text{Bint}} + Q_{\text{Bext}} = -Q_A + 0 = -Q_A$$

$V_B = 0$ and $Q_{\text{Bext}} = 0$ because positive charges flow to earth

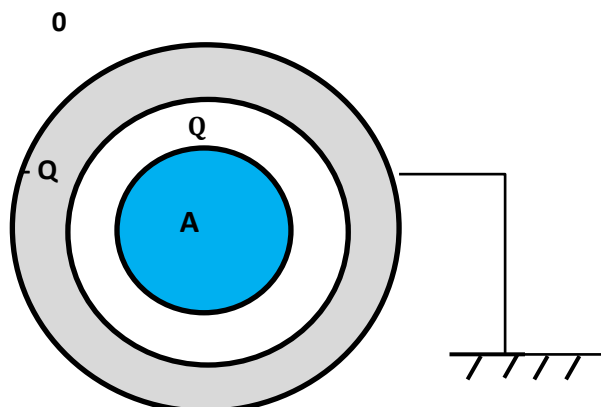

II.8.3. Generalization: Effect of an electric field on a conductor

If we place a conductor in an external electric field \vec{E}_{ext} , the positive charges go in the same direction of the field and the negative charges go in the opposite direction (under the effect of the force $\vec{F}_0 = q\vec{E}_0$) and there is the creation of 2 poles, one positive and another negative. This new distribution of charges forms a field \vec{E}' opposite the field \vec{E}_{ext} , and this process continues until it becomes $E = E_{ext}$, the conductor is in polarized equilibrium. The charge on the conductor has not changed, but the charge distribution and potential have changed.

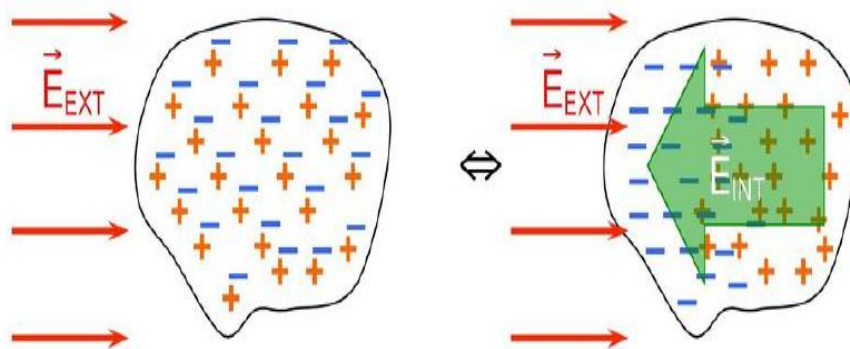

II.8.4. system of n conductors

a) capacity coefficients and influence coefficients

We consider n conductors in electrostatic equilibrium. Each conductor i carries a charge Q_i and a potential V_i . Charges and potentials are related by the equations:

$$\begin{cases} Q_1 = C_{11}V_1 + C_{12}V_2 + \dots + C_{1n}V_n \\ Q_2 = C_{21}V_1 + C_{22}V_2 + \dots + C_{2n}V_n \\ \vdots \\ Q_n = C_{n1}V_1 + C_{n2}V_2 + \dots + C_{nn}V_n \end{cases} \Rightarrow \begin{pmatrix} Q_1 \\ Q_2 \\ \vdots \\ Q_n \end{pmatrix} = \begin{pmatrix} C_{11} & C_{12} & \dots & C_{1n} \\ C_{21} & C_{22} & \dots & C_{2n} \\ \vdots & \vdots & \ddots & \vdots \\ C_{n1} & C_{n2} & \dots & C_{nn} \end{pmatrix} \cdot \begin{pmatrix} V_1 \\ V_2 \\ \vdots \\ V_n \end{pmatrix}$$

C_{ii} : coefficient of conductor capacity i ($C_{ii} > 0$).

C_{ij} : coefficient of influence of the conductor i ($C_{ij} = C_{ji} < 0$).

Exp:

2 conductive spheres in influence:

at equilibrium we have

$$\begin{cases} Q_1 = C_{11}V_1 + C_{12}V_2 \\ Q_2 = C_{21}V_1 + C_{22}V_2 \end{cases}$$

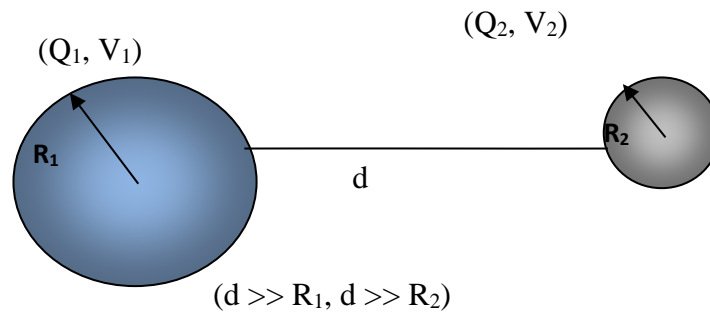

III.8.5. Corresponding Elements Theorem

Consider two conductors A and B in electrostatic equilibrium and carrying surface charge densities σ_A and σ_B ($V_A > V_B$), we bring the two conductors together, an electric field appears between these 2 conductors (from V_A towards V_B), it modifies the distribution of charges on the surface of the two conductors. Consider a small closed contour C_A located on the surface of (A) such that all the field lines resting on C_A join B and draw a closed contour C_B there. The set of these field lines constitutes a flux tube: Let a closed surface produced $S = S_L + S_A + S_B$. According to Gauss' theorem on the closed surface:

$$\phi = \phi_{S_A} + \phi_{S_B} + \phi_{S_L} = \oiint_{S_A} \vec{E} \cdot d\vec{S}_A + \oiint_{S_B} \vec{E} \cdot d\vec{S}_B + \oiint_{S_L} \vec{E} \cdot d\vec{S}_L = \frac{\sum Q_i}{\epsilon_0}$$

$$\oiint_{S_A} \vec{E} \cdot d\vec{S}_A = 0: E \text{ is zero in conductor A}$$

$$\oiint_{S_B} \vec{E} \cdot d\vec{S}_B = 0: E \text{ is zero in conductor B}$$

$$\oiint_{S_L} \vec{E} \cdot d\vec{S}_L = 0: \vec{E} \cdot d\vec{S}_L = 0$$

$$\phi = 0$$

$$\text{So } \phi = 0 = \frac{\sum Q_i}{\epsilon_0} = \frac{q_A + q_B}{\epsilon_0} \Rightarrow q_A + q_B = 0 \Rightarrow q_B = -q_A$$

$$\boxed{q_B = -q_A}$$

Corresponding Elements Theorem: Faraday's Theorem: "The charges carried by the two corresponding surface elements facing each other are equal and of opposite signs."

II.9. Capacitor

A capacitor is made up of 2 conductors in total influence separated by a vacuum and an insulator. These conductors are called plates of the capacitor. We call Q the charge of the capacitor (armature). Let V1 and V2 be the respective potentials of the internal and external armatures.

The capacitance of the capacitor is

$$C = \frac{Q}{V_1 - V_2}$$

A capacitor is used to store electrical energy, by storing charges on its armatures, we represent the capacitor by:

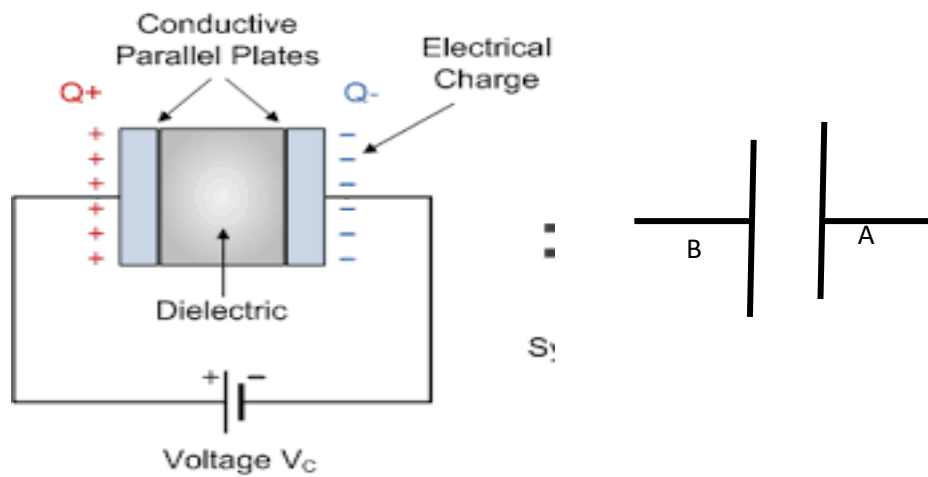

Types of Capacitor

II.9.1. Calculating the capacitance of a capacitor

To calculate the capacitance of a capacitor you must follow the following steps:

- 1- Calculate the field between the armatures (using the Gauss theorem)
- 2- Deduce the potential difference between the conductors ($\vec{E} = -\overrightarrow{grad}V$)
- 3- Calculate the ratio $C=Q/(V_1 - V_2)$

II.9.2. Capacitor association in electric circuits

a) Series capacitors

Let n be capacitors of capacitances C_i connected in series. The difference of potential across each of the capacitors is therefore:

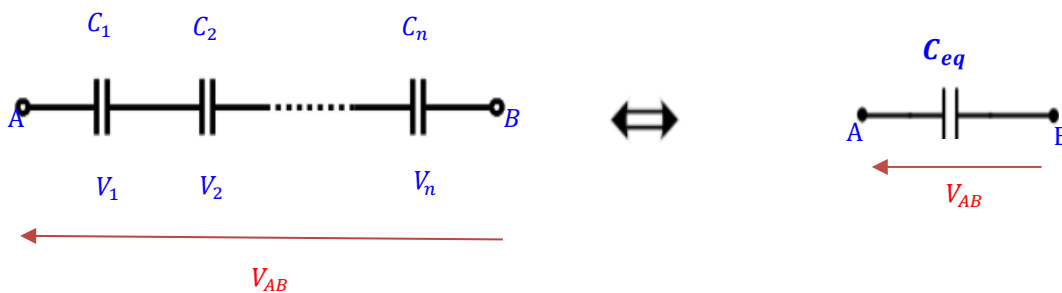

$$V_1 = \frac{Q_1}{C_1}, \quad V_2 = \frac{Q_2}{C_2} \dots V_n = \frac{Q_n}{C_n}$$

$$V_{AB} = V_1 + V_2 + \dots + V_n$$

$$V_{AB} = \frac{Q}{C_1} + \frac{Q}{C_2} + \dots + \frac{Q}{C_n}$$

The association then behaves like a “single equivalent capacitor” of capacitance C_{eq}

$$V_{AB} = \frac{Q}{C_{eq}}$$

$$\frac{1}{C_{eq}} = \frac{1}{C_1} + \frac{1}{C_2} + \dots + \frac{1}{C_n} = \sum_1^n \frac{1}{C_i}$$

$$\boxed{\frac{1}{C_{eq}} = \sum_1^n \frac{1}{C_i}}$$

b) Parallel capacitors

Let n capacitors of capacitances C_i be placed in parallel with the same voltage

$$V_{AB} = V_1 = V_2 = \dots = V_n$$

The electric charge of each of them is given by:

$$Q_i = C_i U$$

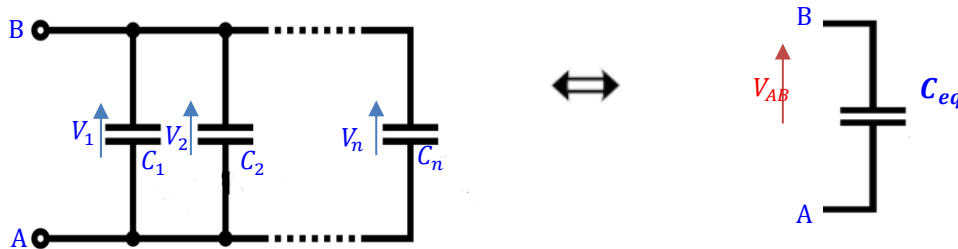

$$Q = \sum_{i=1}^n Q_i = Q_1 + Q_2 + \dots + Q_n$$

$$Q = \sum_{i=1}^n Q_i = C_1 V_1 + C_2 V_2 + \dots + C_n V_n = \sum_{i=1}^n C_i V_{AB}$$

The association then behaves like a “single equivalent capacitor” of capacitance C_{eq}

$$Q = C_{eq} V_{AB}$$

$$C_{eq} = C_1 + C_2 + \dots + C_n = \sum_{i=1}^n C_i$$

$$\boxed{C_{eq} = \sum_{i=1}^n C_i}$$

II.9.3. Electrical energy stored by a capacitor

A capacitor stores an amount of electrical energy equal to the work done to charge it, for example using a battery. Suppose that at a given moment, the charge already accumulated on the armature, i.e. q .

Therefore, the potential difference between the armatures is worth $V=q/C$.

The work required to pass an infinitesimal charge dq from the negative armature to the positive armature, via the battery is:

$$dW = Vdq = \frac{q}{C} dq$$

The total work W , for charging an uncharged capacitor with a charge Q is obtained by integrating:

$$W = \int_0^Q \frac{q}{C} dq = \frac{1}{2} \frac{Q^2}{C} = \frac{1}{2} CV^2$$

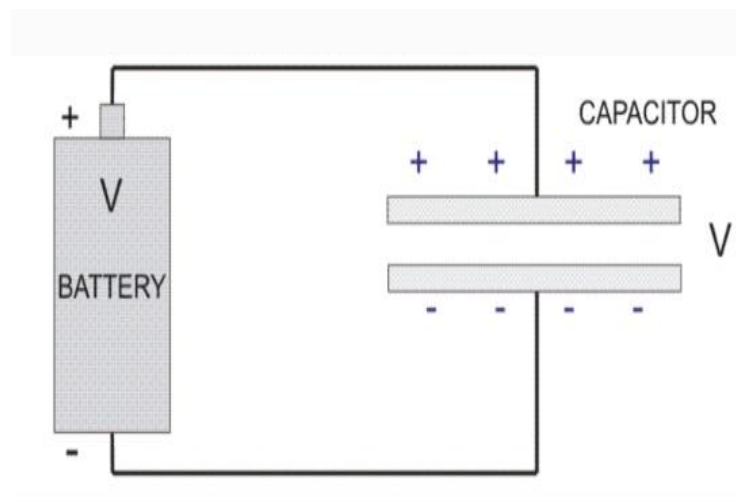

Exercises

Exercise 1

Find the charge acquired by a conducting sphere S of radius $R = 50\text{cm}$ when it is carried at a potential $V = 200\text{V}$.

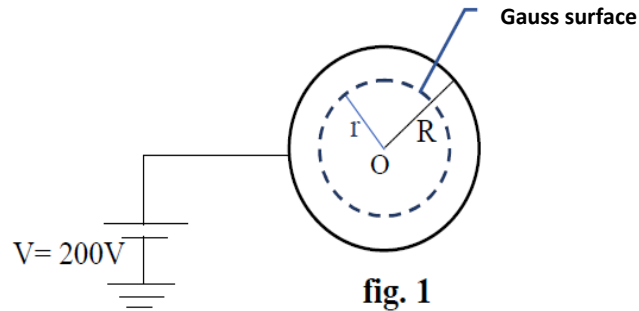

Exercise 2

Consider a plane capacitor made up of two parallel conducting plates of area S , separated by a small distance e , charged with two surface charge densities $(+\sigma)$ and $(-\sigma)$.

-Calculate the capacitance of this capacitor. (we assume that $e \ll S$)

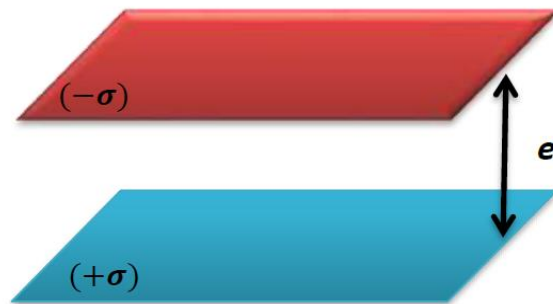

Exercise 3

The cylindrical capacitor consists of two coaxial conducting cylinders of radii R_1 and R_2 ($R_1 < R_2$), the first carries a positive charge Q and the second carries a negative charge $-Q$.

-Calculate the capacitance of this capacitor.

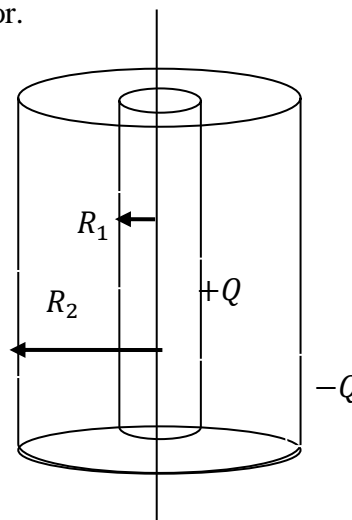

Exercise 4

Consider a spherical capacitor made up of two concentric spheres of radius R_1 and R_2 ($R_1 < R_2$), in total influence.

-Calculate the capacitance of this capacitor.

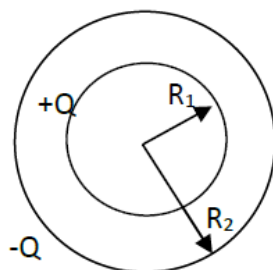

Solution

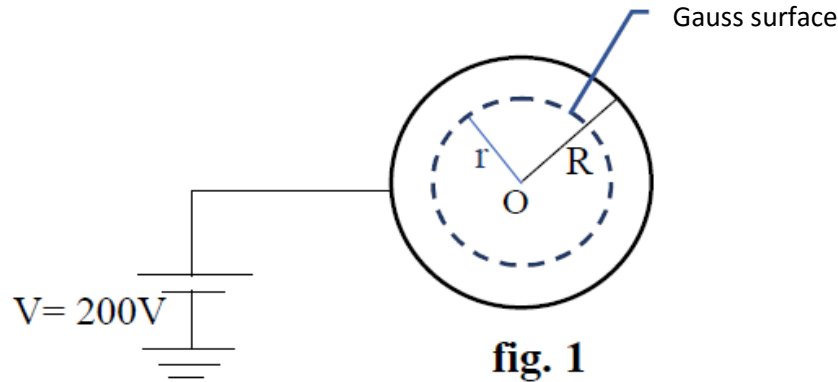
Exercise 1

We have a conductive sphere S of radius R connected to a potential $V = 200\text{ V}$ (fig.1). So S carries a potential $V(R) = 200\text{V}$.

In order to be able to calculate the charge Q that this sphere S carries, we must first determine the relationship of its potential V

We must first determine the relationship of its potential V

According to Gauss's theorem, we have:

$$\Phi_S = \oiint_S \vec{E}(M) \cdot d\vec{S}(M) = \frac{\sum Q_i}{\epsilon_0}$$

$$\Phi_S = ES_G = \frac{Q}{\epsilon_0}$$

Since the conductor is spherical, the Gauss surface S_G is a sphere of radius r (fig.1)

$$S_G = 4\pi r^2 \Rightarrow E \cdot 4\pi r^2 = \frac{Q}{\epsilon_0}$$

$$E = \frac{Q}{4\pi r^2 \epsilon_0}$$

On the other hand, we have:

$$\vec{E} = -\overrightarrow{\text{grad}}V \Rightarrow E = -\frac{dV}{dr} \Rightarrow \int_V^\infty dV = -\int_R^\infty E \cdot dr$$

The potential at infinity is zero, $V(\infty)=0$

$$\boxed{Q = 4\pi\epsilon_0 RV}$$

N.A: $Q = 11,1 \cdot 10^{-9}\text{ C}$

Note:

The capacity of a conductor is defined by the relation: $C = \frac{Q}{V}$; in our case (a spherical conductor) the capacitance will take the relation: $C = \frac{Q}{V} = 4\pi\epsilon_0 R$. We clearly notice that C only depends on the geometry of the conductor (its radius of curvature R).

Exercise 1

It is made up of two parallel planes in total influence, spaced by a thickness e, the first carries a positive density σ and the second carries a negative density $-\sigma$.

We assume that e is very small compared to the dimensions of the plates which allows us to consider them as “infinite”.

1) $\vec{E}_1 \perp$ on the plane and leaving the plane (positive charge)

$\vec{E}_2 \perp$ to the plane and entering the plane (negative charge)

Outside the frames $\vec{E}_{total} = \vec{E}_1 + \vec{E}_2 = \vec{0}$

Between the two frames, we have: $\vec{E}_{total} = \vec{E}_1 + \vec{E}_2$

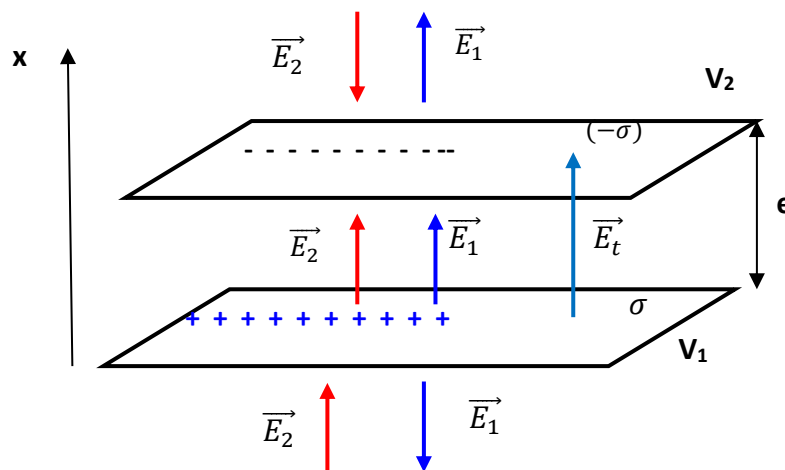

Gauss 's theorem

$$\Phi = \oiint_S \vec{E} \cdot d\vec{S} = \frac{\Sigma Q_{int}}{\epsilon_0}$$

Let us take as *Gaussian surface* a cylinder with axis perpendicular to the plane (+).

$$\phi(\vec{E}_1) = \phi_{S_1}(\vec{E}_1) + \phi_{S_2}(\vec{E}_1) + \phi_{S_3}(\vec{E}_1) = \oiint_{S_1} \vec{E}_1 \cdot d\vec{S}_1 + \oiint_{S_2} \vec{E}_1 \cdot d\vec{S}_2 + \oiint_{S_3} \vec{E}_1 \cdot d\vec{S}_3$$

The field \vec{E}_1 is perpendicular to $d\vec{S}_3 \Rightarrow \phi_{S_3} = 0$

$$\vec{E}_1 // d\vec{S}_1 \text{ and } \vec{E}_1 // d\vec{S}_2$$

$$\phi(\vec{E}_1) = \phi_{S_1} + \phi_{S_2} = E_1 S_1 + E_1 S_2 = 2E_1 S_1 = 2E_1 S \quad (S_1 = S_2 = S)$$

The charge contained in the *Gaussian surface* is

$$\Sigma Q_{int} = \iint_S dq = \sigma \iint_S dS = \sigma S$$

$$\phi(\vec{E}_1) = 2E_1 S = \frac{\sigma S}{\epsilon_0} \Rightarrow \boxed{E_1 = \frac{\sigma}{2\epsilon_0}}$$

The same result for the (-) plane:

$$\boxed{E_2 = \frac{\sigma}{2\epsilon_0}}$$

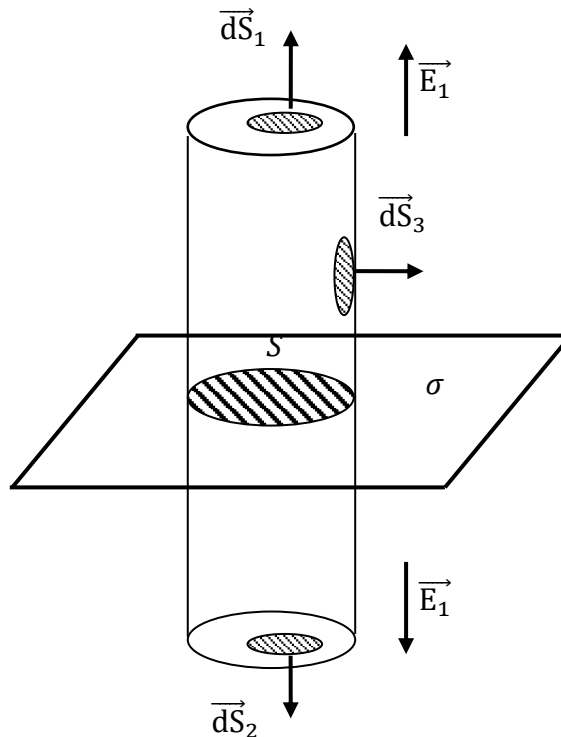

$$E_{total} = E_1 + E_2 = \frac{\sigma}{2\epsilon_0} + \frac{\sigma}{2\epsilon_0} \Rightarrow \boxed{E_{tot} = E = \frac{\sigma}{\epsilon_0}}$$

$$2)\vec{E} = -\overrightarrow{grad}V \Rightarrow E = -\frac{dV}{dx} \Rightarrow \int_{V_1}^{V_2} dV = -\int_0^e E \cdot dx$$

$$V_2 - V_1 = -\frac{\sigma}{\epsilon_0} e \Rightarrow V_1 - V_2 = \frac{\sigma e}{\epsilon_0}$$

$$3) C = \frac{Q}{V_1 - V_2} = \frac{Q}{\frac{\sigma e}{\epsilon_0}} = \frac{\sigma S}{\frac{\sigma e}{\epsilon_0}} = \boxed{\frac{S \epsilon_0}{e} = C}$$

We notice that the capacitance does not depend on the charge or the potential, it depends on the dimensions of the capacitor and the medium in which it is placed (here the vacuum ϵ_0)

Exercise 2

The cylindrical capacitor consists of two coaxial conducting cylinders of radii R_1 and R_2 ($R_1 < R_2$), the first carries a positive charge Q and the second carries a negative charge $-Q$.

1) By applying Gauss's theorem. *Let us take a cylinder as a Gaussian surface.*

of height h and radius r ($R_1 < r < R_2$). By reason of symmetry, \vec{E} is radial and constant in the Gaussian surface.

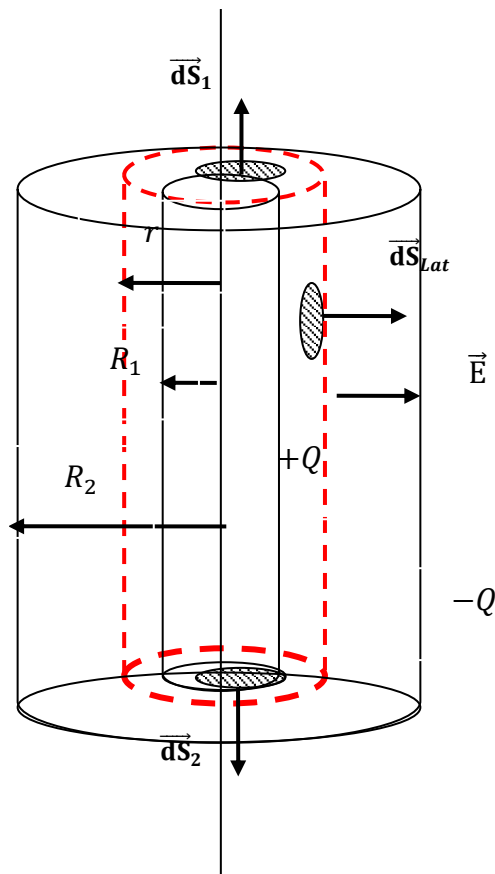

$$\phi(\vec{E}) = \phi_{S_1}(\vec{E}) + \phi_{S_2}(\vec{E}) + \phi_{S_3}(\vec{E}) = \iint_{S_1} \vec{E} \cdot d\vec{S}_1 + \iint_{S_2} \vec{E} \cdot d\vec{S}_2 + \iint_{S_3} \vec{E} \cdot d\vec{S}_3$$

The field \vec{E} is perpendicular to S_1 et $S_2 \Rightarrow \phi_{S_1} = \phi_{S_2} = 0$

$$\vec{E} // d\vec{S}_3 = d\vec{S}_{Lat}$$

$$\phi(\vec{E}) = ES_3 = E2\pi rh$$

The charge contained in the *Gaussian surface* is $\Sigma Q_{int} = Q$

$$\phi(\vec{E}) = E2\pi rh = \frac{Q}{\epsilon_0} \Rightarrow \boxed{E = \frac{Q}{\epsilon_0 2\pi rh}}$$

$$2) \vec{E} = -\overrightarrow{grad}V \Rightarrow E = -\frac{dV}{dr} \Rightarrow \int_{V_1}^{V_2} dV = -\int_{R_1}^{R_2} E \cdot dr$$

$$V_2 - V_1 = -\int_{R_1}^{R_2} \frac{Q}{\epsilon_0 2\pi rh} \cdot dr = -\frac{Q}{\epsilon_0 2\pi h} \ln r \Big|_{R_1}^{R_2} \Rightarrow V_1 - V_2 = \frac{Q}{\epsilon_0 2\pi h} \ln \frac{R_2}{R_1}$$

$$C = \frac{Q}{V_1 - V_2} = \frac{Q}{\frac{Q}{\epsilon_0 2\pi h} \ln \frac{R_2}{R_1}} = \frac{\epsilon_0 2\pi h}{\ln \frac{R_2}{R_1}} = \boxed{\epsilon_0 2\pi h \cdot \ln \frac{R_1}{R_2} = C}$$

Exercise 3

It is made up of two concentric spheres of radius R_1 and R_2 ($R_1 < R_2$), in total influence.

1-1) By applying Gauss's Theorem, let us calculate the electrostatic field created by a sphere with center O and radius $R_1 < r < R_2$.

-For reasons of symmetry, the vector \vec{E} is radial and has the same modulus on the Gaussian surface, the flow leaving this sphere is:

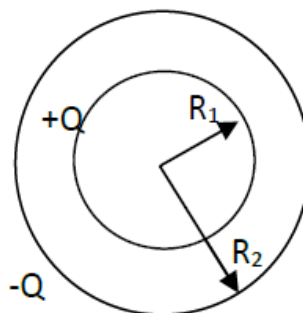

$$\phi = \oint_{S_G} \vec{E} \cdot d\vec{S} = E \cdot S_G = E4\pi r^2 \quad (\vec{E} // d\vec{S})$$

$$\boxed{\phi = E4\pi r^2}$$

The charge contained in the Gaussian surface is

$$\Sigma Q_{int} = Q.$$

By applying Gauss's theorem:

$$\phi(\vec{E}) = E4\pi r^2 = \frac{\Sigma Q_{int}}{\epsilon_0} = \frac{Q}{\epsilon_0}.$$

$$\Rightarrow \boxed{E = \frac{Q}{4\pi r^2 \epsilon_0}}$$

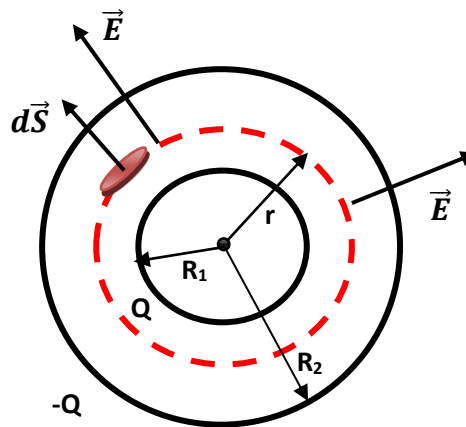

$$1-2) \vec{E} = -\overrightarrow{grad}V \Rightarrow E = -\frac{dV}{dr} \Rightarrow \int_{V_1}^{V_2} dV = -\int_{R_1}^{R_2} E \cdot dr$$

$$V_2 - V_1 = -\frac{Q}{4\pi\epsilon_0} \left(-\frac{1}{R_2} + \frac{1}{R_1} \right) \Rightarrow V_1 - V_2 = \frac{Q}{4\pi\epsilon_0} \left(\frac{1}{R_1} - \frac{1}{R_2} \right)$$

$$\boxed{V_1 - V_2 = \frac{Q}{4\pi\epsilon_0} \left(\frac{1}{R_1} - \frac{1}{R_2} \right)}$$

$$1-3) C = \frac{Q}{V_1 - V_2} = \frac{4\pi\epsilon_0 R_1 R_2}{R_2 - R_1}$$

$$C = \frac{4\pi\epsilon_0 R_1 R_2}{R_2 - R_1}$$

2) Calculation of the capacity C if R_2 tends towards R_1

$$\text{If } R_2 \rightarrow R_1 \Rightarrow \begin{cases} R_2 - R_1 \approx e \ll \\ R_1 R_2 \approx R^2 \end{cases}$$

$$\Rightarrow C = \frac{4\pi\epsilon_0 R^2}{e}$$

The surface of the sphere $S = 4\pi R^2$

$$C = \frac{S\epsilon_0}{e}$$

Similar to that of a planar capacitor

Chapter 3

Electrokinetics

Gustav Robert Kirchhoff (1824-1887)

Born in Prussia, Germany. Studied with Neumann and in 1841 published his famous Kirchhoff's laws. He extended Ohm's electrical theories. Later he studied spectra from various elements. He worked with Robert Bunsen and studied radiation spectrum from the sun. He also worked on black body radiation, which was very important in the development of Quantum Theory. After he was disabled in crutches and a wheelchair he turned from experimental physics to theoretical physics. He became Chair of Mathematical physics in Berlin. He was known as a masterful teacher with clarity and rigor in his thinking and teaching.

Andre-Marie AMPER (Ampère) (22.01.1775 - 10.06.1836) Andre-Marie Amper is a French physicist, mathematician and chemist. He was born in Lyon in the family of a merchant. In his father's beautiful library were works of famous philosophers, scientists and writers. Young André could sit there all day with a book, so that he, who never attended school, was able to acquire extensive and profound knowledge



III.1. Introduction

Electrokinetics is the study of electrical charges in motion.

Electrokinetics is the study of electric currents, *i.e.* the study of electrical charges moving in material media called conductors. In other words, it is the study of electrical circuits and networks.

III.2. Electrical conductor

A conductor, or electrical conductor, is a substance or material that allows electricity to flow through it. In a conductor, electrical charge carriers (), usually electrons, move easily when voltage is applied.

Some examples of conductors of electricity are: Copper, Aluminium, Silver, Gold, Graphite, Platinum, Water, Human Body, ...

In some materials the electrons can wander about between the atoms, these electrons are called **free electrons**. In some materials, electrons can move between atoms (their movement is irregular), and these electrons are called free electrons. But if we now connect a battery to both ends of the wire, the electrons drift and their movement is in one direction.

The more free electrons there are in a solid the better it will conduct electricity.

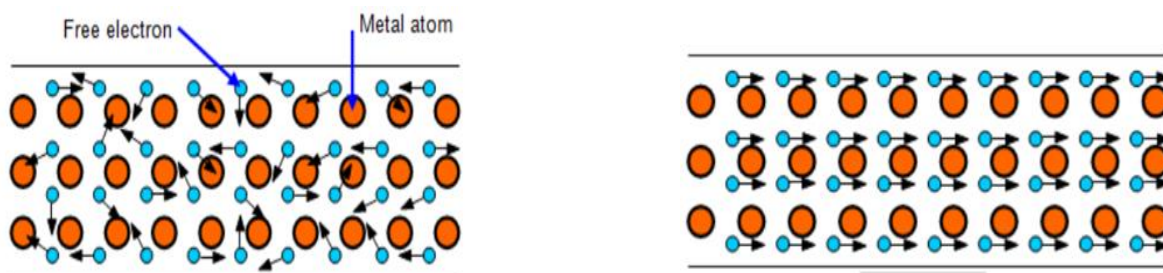

III.3. Electric current

Consider two charged conductors A and B at potentials V_A and V_B such that $V_A > V_B$. They are connected by a conductor wire to obtain a single conductor (A-wire-B) which does not have the same potential in all points: there is a potential difference dV between 2 points of the wire. This results in an electric field $E = -dV/dr$, which makes the charges to move. These charges movement forms an electric current which flows from A to B. Therefore, an electric current is a flow of charged particles. It is characterized by intensity and direction.

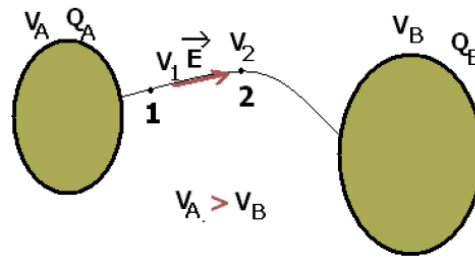

III.3.1 Definition:

An electric current is a movement of a group of electric charge carriers, generally electrons, within a conductive material. To have an electric current in a conductor, it would have to establish a difference of potential between the terminals of this conductor.

III.3.2. Properties of Electric Current

a) Intensity

The intensity of the electric current is given by the number of electric charges which cross a surface (section of conductive wire S) for a duration of time dt .

$$I = \frac{dq}{dt}$$

with: $I(t)$: current intensity; dq : the elementary electric charge; dt : the interval of time.

b) Unit

in the International System of Units (SI), the electric current is expressed in units of ampere symbol (A), which is equivalent to one coulomb per second.

$$1 \text{ Amper} = 1 \text{ Coulomb} / 1 \text{ second}$$

The ampere is an SI base unit and the electric current is a base quantity measured using a device called an *ammeter*.

c) The conventional direction

By convention, the electric current always flows from the positive (+) terminal to the negative (-) terminal outside the generator.

The electrons flow is from negative to positive terminal. Electrons are negatively charged and are therefore attracted to the positive terminal.

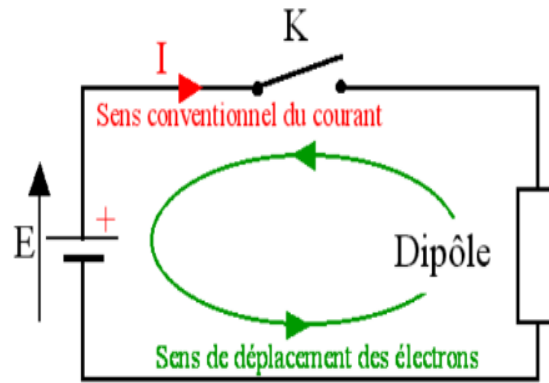

d) types of electric current

There are two types of electric current known as [alternating current \(AC\)](#) and [direct current \(DC\)](#). The direct current can flow only in one direction, whereas the alternating direction flows in two directions. Direct current is rarely used as a primary energy source in industries. It is mostly used in low voltage applications such as charging batteries, aircraft applications, etc. Alternating current is used to operate appliances for both household and industrial and commercial use.

III.3.3. Density of electric current

Consider a number n of charges q , which move with a speed \vec{v} , in a conductor of section dS and volume V . In a time dt the charges travel a distance $\vec{dl} = \vec{v} \cdot dt$, therefore the quantity of charge dQ contained in the volume dV is given by:

$$dQ = n \cdot q \cdot dV$$

We have : $dV = \vec{dl} \cdot \vec{dS}$

$$dQ = nq \vec{dl} \cdot \vec{dS} = nq\vec{v} \cdot dt \cdot \vec{dS}$$

we pose: $\vec{J} = nq\vec{v}$

So $dQ = \vec{J} \cdot \vec{dS} \cdot dt$

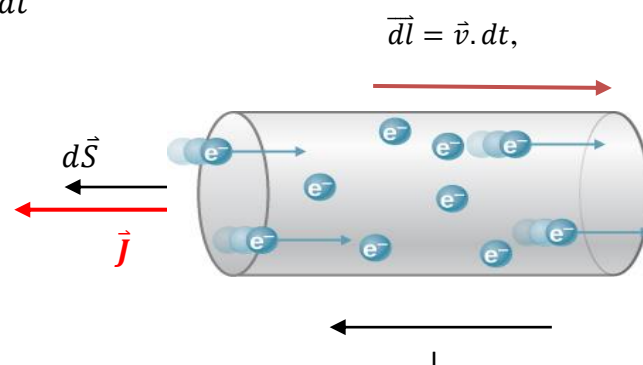

Definition:

The density of the electric current \vec{j} is a vector quantity which equals the charge per unit of time across the unit of surface, it is expressed in $A.m^{-2}$.

In the case of a conductor composed of free electrons

$$q = -e \Rightarrow \vec{j} = -nev \Rightarrow J = nev$$

Therefore the current I flowing through the surface dS is given by:

$$I = \frac{dQ}{dt} = \frac{\vec{j} \cdot \overrightarrow{dS} \cdot dt}{dt} = \vec{j} \cdot \overrightarrow{dS}$$

So I which crosses the entire section S is:

$$I = \iint \vec{j} \cdot \overrightarrow{dS}$$

Therefore, the intensity of the current passing through the section S is equal to the flux of current density through S

III.4. Ohm's law

III.4.1. Macroscopic ohm's law

Ohm's law states that the voltage across a conductor is directly proportional to the current flowing through it, provided all physical conditions and temperatures remain constant.

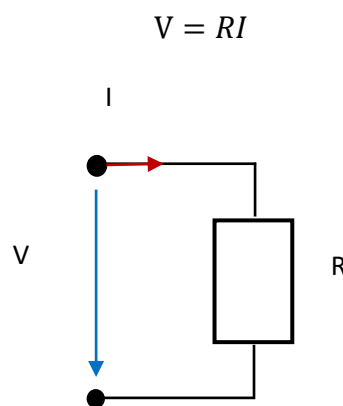

V : Volt (V)

i : Ampere (A)

R: Ohms (Ω)

In the equation, the constant of proportionality, R, is called *Resistance* and has units of Ohms, with the symbol Ω .

Resistance is opposition exerted by a body to the passage of a current.

III.4.2. local ohm's law

a) conductivity:

Consider a cylindrical conductor of length l and section S , be subjected to a potential difference V

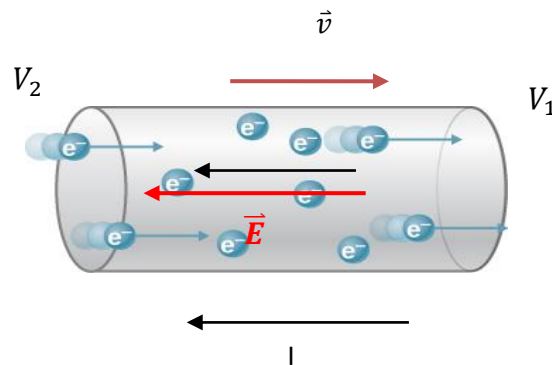

the field \vec{E} :

$$V = V_1 - V_2 = \int \vec{E} \cdot d\vec{l} = E \cdot l$$

$$V = RI = E \cdot l$$

We have: $I = JS \Rightarrow V = R \cdot J \cdot S = E \cdot l$

$$\Rightarrow J = \frac{E \cdot l}{R \cdot S}$$

We pose: $\sigma = \frac{l}{R \cdot S} \Rightarrow J = \sigma \cdot E$ and $\Rightarrow \vec{J} = \sigma \cdot \vec{E}$

σ : conductivity of the conductor, expressed in $\Omega^{-1} \cdot m^{-1}$

b) Resistivity:

The inverse of σ is called the resistivity ρ :

$$\rho = \frac{1}{\sigma}$$

where ρ is a constant (for a given material at a given temperature) known as the resistivity () of the material. Some selected values for ρ are:

$$\rho_{\text{Copper}} = 1.72 \times 10^{-8} \Omega \cdot m, \rho_{\text{Aluminum}} = 2.82 \times 10^{-8} \Omega \cdot m, \rho_{\text{Carbon}} = 3.5 \times 10^{-5} \Omega \cdot m$$

Relationship between Resistance and Resistivity

The resistance of a piece of material depends on the type and shape of the material. If the piece has length L and cross-sectional area S , the resistance is:

$$R = \rho \frac{l}{S}$$

Relationship between Resistivity and conductivity

Since conductivity is the measure of how easily electricity flows, electrical resistivity measures how much a material resists the flow of electricity.

Conductivity and resistivity are inversely proportional to each other. When conductivity is low, resistivity is high. When resistivity is low, conductivity is high. The proportionality is as follows:

$$\rho = \frac{1}{\sigma}$$

where :

- Resistivity is represented by ρ and is measured in **Ohm-meters** ($\Omega.m$),
- Conductivity is represented by σ and is measured in **Siemens** ($1/\Omega.m$).

c) Mobility

In a conductor the electrons are subjected to the force F_e :

$$F_e = eE = m_e a = m_e \frac{dv}{dt} \Rightarrow dv = \frac{F_e \cdot dt}{m_e}$$

$$\Rightarrow dv = \frac{e \cdot E \cdot dt}{m_e} \Rightarrow v = \frac{e \cdot E \cdot t}{m_e}$$

$$\text{We pose : } \mu = \frac{e \cdot t}{m_e} \Rightarrow v = \mu \cdot E \quad \text{and} \quad \Rightarrow \vec{v} = \mu \cdot \vec{E}$$

μ : mobility

we also have:

$$\sigma = \frac{J}{E} = \frac{nev}{E} = ne\mu = \frac{ne \cdot et}{E \cdot m_e} = \frac{ne^2 t}{E \cdot m_e}$$

$$\Rightarrow \mu = \frac{\sigma}{n \cdot e}$$

n: number of electrons per m^3 .

III.5. The Joule Effect and Electric Power

The Joule effect phenomenon is defined as the effect of heat production during of the electric current flow in a conductor. So, a fraction of the electrical energy is transformed into calorific energy (energy dissipated in the form of heat).

As charge moves through the wires of an electric circuit, they lose electric potential energy. (When charge Δq moves through a potential difference V , it loses ΔqV of potential energy.)

The power dissipated by this conductor is equal to:

$$P = \frac{\Delta q \cdot V}{\Delta t}$$

that is:

$$P = IV = RI^2 = \frac{V^2}{R}$$

The electric power is measured in joules per second, or watts: $1 \text{ J/s} = 1 \text{ W}$.

The energy goes into heating the resistor or **the energy consumed by a resistor during time (Δt) is:**

$$E = P \cdot \Delta t = RI^2 \cdot \Delta t$$

III.6. Association of Resistors

Fundamentally we have three types of resistance associations that we can find in electrical circuits: association type series, parallel and mixed.

a. Series Association

In a **series circuit**: the current is the same in each resistor

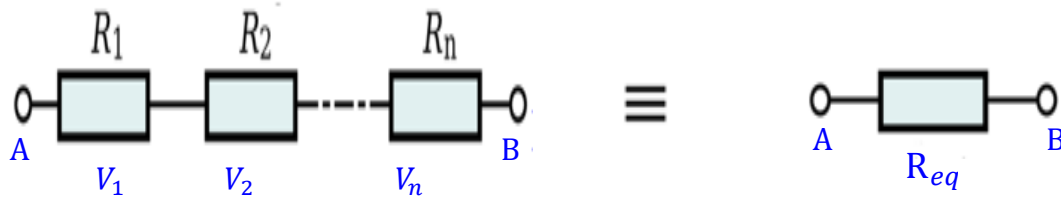

$$V_{AB} = V_1 + V_2 + \dots + V_n$$

$$I = I_1 = I_2 = \dots = I_n$$

$$V_{AB} = R_1I + R_2I + \dots + R_nI = R_{eq}I$$

$$R_{eq} = R_1 + R_2 + \dots + R_n = \sum_{i=1}^n R_i$$

$$R_{eq} = \sum_{i=1}^n R_i$$

b. Parallel Association

All resistances will be subjected to the same potential difference V_{AB} . Therefore, the current that will circulate in each resistance will only depend on its ohmic value.

The total current flowing through the circuit is the sum of the currents in each circuit resistance.

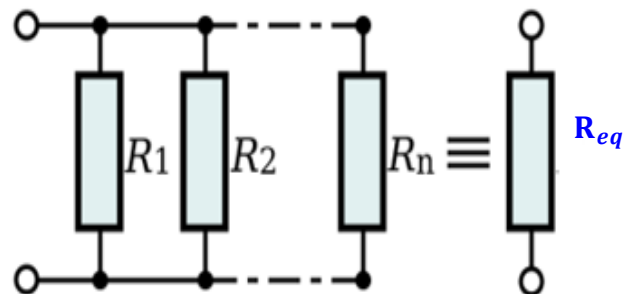

$$V_{AB} = V_1 = V_2 = \dots = V_n$$

$$I = \sum_{i=1}^n I_i = I_1 + I_2 + \dots + I_n$$

$$I = \frac{V}{R_1} + \frac{V}{R_2} + \dots + \frac{V}{R_n} = \frac{V}{R_{eq}}$$

$$\frac{1}{R_{eq}} = \frac{1}{R_1} + \frac{1}{R_2} + \dots + \frac{1}{R_n} = \sum_1^n \frac{1}{R_i}$$

$$\boxed{\frac{1}{R_{eq}} = \sum_1^n \frac{1}{R_i}}$$

III.7. Electrical circuits

An electrical circuit is a set of electrical components such as: resistors, capacitors, and conductors etc., carried by an electric current.

So, the electrokinetics of an electric circuit consists of finding the intensity of the current and the voltage for each location in this circuit.

a. Circuit diagrams

A circuit diagram uses circuit symbols to represent each component in the circuit.

A circuit diagram shows how the components are connected.

Use straight lines to show the *wires* and *circuit symbols* to represent each component.

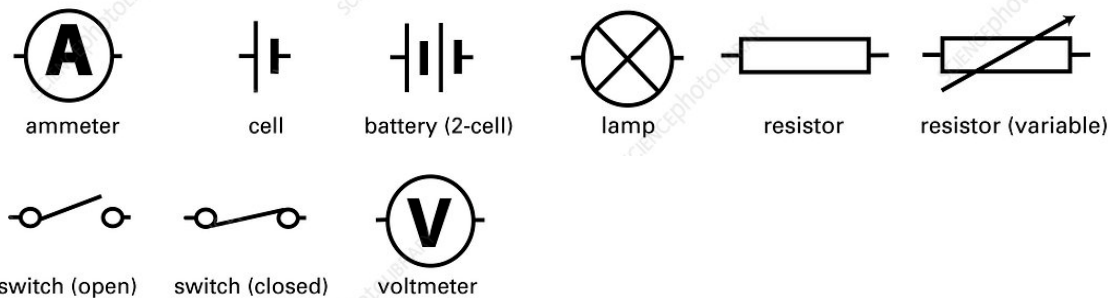

Before we go into Kirchhoff's rules, we first define basic things in circuit analysis which will be used in applying Kirchhoff's rules.

Node is a point common to at least three branches.

Branch consists of one or more elements located between two nodes and through which the same current passes.

Loop: It is a closed path in a circuit consisting of two or more branches. The starting point is the end.

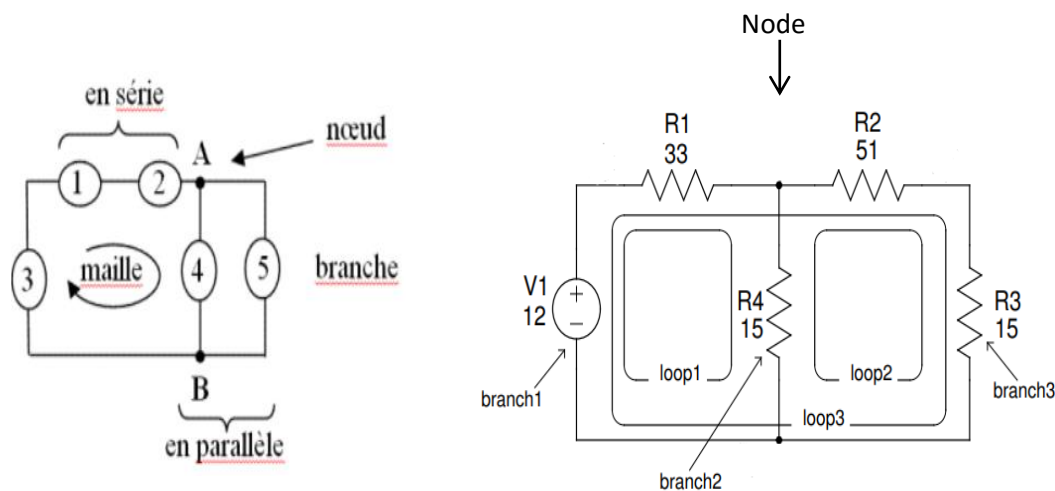

b. Generators

An electrical circuit requires a power source to power it. So, it is essential to connect these circuits by a device called a generator (electromotive force) to ensure the transport of electrical charges.

There are two categories of generators:

1. Voltage generator

In the case of an ideal voltage generator the electromotive force (*emf*) is equal to the potential difference between these terminals:

$$U_{AB} = V_A - V_B = E$$

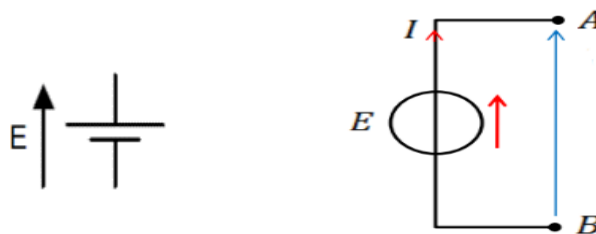

A real voltage generator is an ideal voltage generator *E* in series with a resistor

$$U_{AB} = V_A - V_B = E - rI$$

r: is the internal resistance of the source

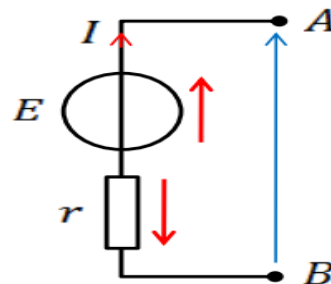

2. Current generator

An ideal current generator delivers a constant current independently of the potential difference between its terminals.



A real current generator is an ideal current generator *I*₀ in parallel with a resistance *r*.

The current *I* supplied by the generator is:

$$I = I_0 - U/r.$$

r: is the internal resistance of the generator

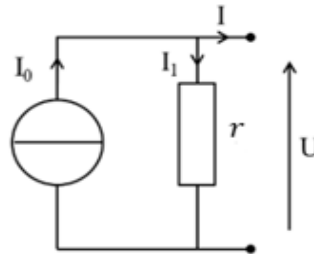

III.8. Kirchhoff's laws

The principle of conservation of energy and charge in electrical circuits is expressed by a set of rules called *Kirchhoff's laws*.

1. Law of Nodes-

The law of nodes is known by the first Kirchhoff law: The sum of the intensities of the currents entering a node is equal to the sum of the intensities of the currents leaving it.

$$I_1 + I_2 + I_3 = I_4 + I_5 + I_6$$

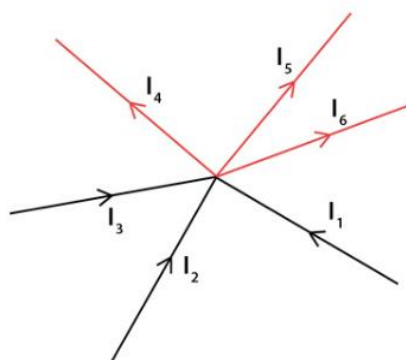

In other words, the sum of the currents in a node equals zero

$$\sum_{i=1}^n I_i = 0$$

$$I_1 + I_2 + I_3 - I_4 - I_5 - I_6 = 0$$

2. The loops law

This is the Kirchhoff's second law in a loop of an electrical circuit.

The algebraic sum of the potential drops (potential differences) of the loop elements is zero.

$$\sum_{k=1}^n U_k = 0$$

Here, n is the total number of voltages measured

$$U_{ab} + U_{bc} + U_{cd} + U_{da} = 0$$

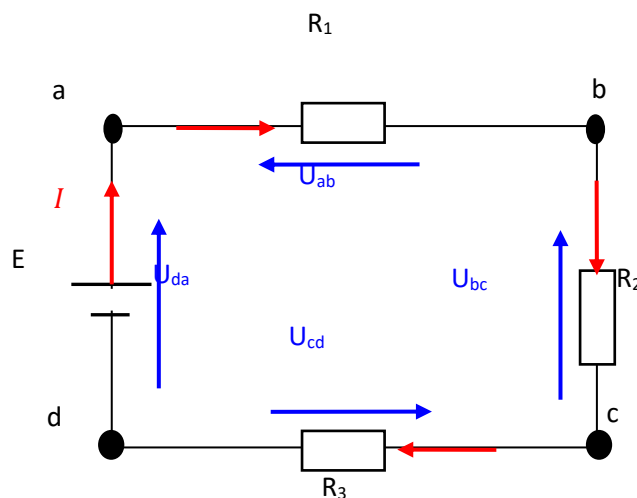

Applying Kirchhoff's Laws

By applying Kirchhoff's rules, we generate equations that allow us to find the unknowns in circuits. The unknowns may be currents, voltages or resistances.

1. When applying Kirchhoff's first rule, the node (junction) rule, you must label the current in each branch and decide in what direction it is going.

There is no risk here, if you choose the wrong direction, the current will be of the correct magnitude but negative.

2. When applying Kirchhoff's second rule, the loop rule, you must identify a closed loop and decide in which direction to go around it, clockwise or counterclockwise

Again, there is no risk; going around the circuit in the opposite direction reverses the sign of every term in the equation, which is like multiplying both sides of the equation by -1 .

The following points will help you get the plus or minus signs right when applying the loop rule.

- When a resistor is traversed in the same direction as the current, the change in potential (voltage) is $-IR$.
- When a resistor is traversed in the direction opposite to the current, the change in potential is $+IR$
- When an emf is traversed from $-$ to $+$ (the same direction it moves positive charge), the change in potential is $+emf (+E)$.
- When an emf is traversed from $+$ to $-$ (opposite to the direction it moves positive charge), the change in potential is $-emf (-E)$.
- The direction of the current is represented by an arrow placed on a connection wire, and oriented according to the conventional direction of the electric current.

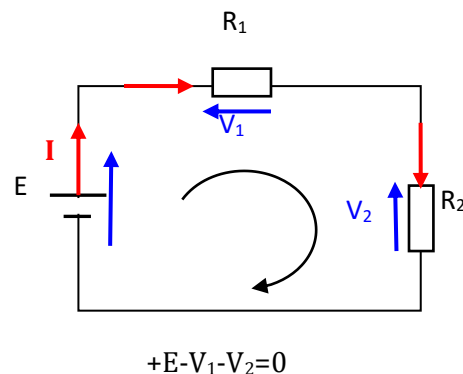
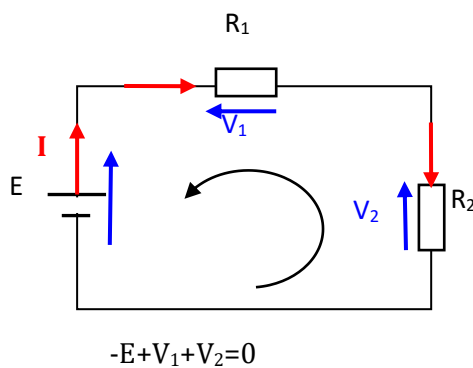
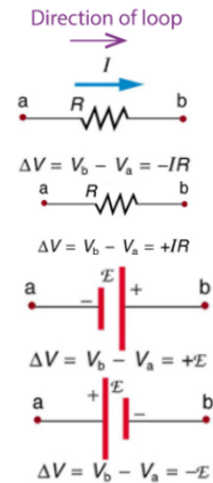

III.9. Thevenin's theorem

A linear two-terminal (A and B) circuit consisting of a number of voltage sources and resistances can be replaced by an equivalent network having a single voltage source called Thevenin's voltage (E_{Th}) and a single series resistance called Thevenin's resistance (R_{Th}), where E_{Th} is the open-circuit voltage at the terminals AB and R_{Th} is the equivalent resistance as seen from the open terminals when the voltage sources are turned off (short circuit).



Exercises

Exercise 1

Using Kirchhoff's Circuit Laws, find the current flowing through each loop I_1 , I_2 , and the current I_3 flowing in the resistor R_3 .

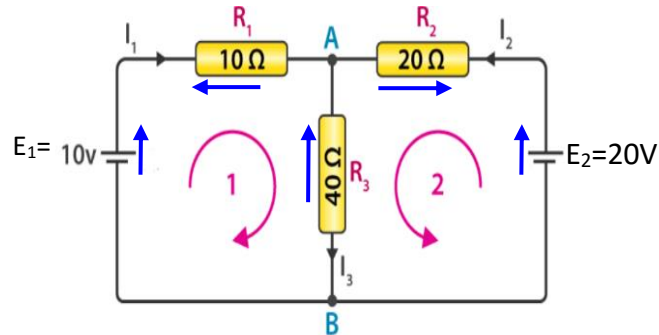

Exercise 2

Consider the circuit as shown ($E=16V$, $R_1=2\Omega$, $R_2=6\Omega$, $R_3=10\Omega$, $R_L=4\Omega$). Use Thevenin's theorem to determine the voltage (V_L) and current (I_L) across the load resistance R_L .

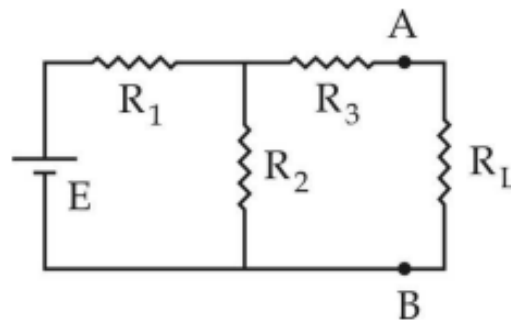

Exercise 3

Use Thevenin's theorem to determine the voltage (V_{AB}) and current (I_{AB}) across the resistance R_2 .

$E_1=10V$, $E_2=20V$, $R_1=10\Omega$, $R_2=40\Omega$, $R_3=20\Omega$

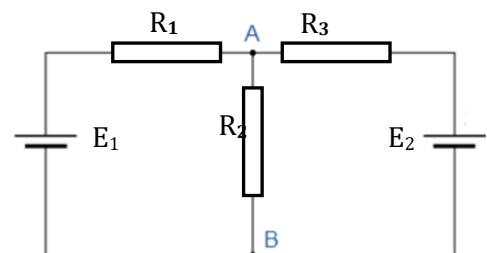

Solution

Exercise 1

Step 1:

The first and foremost step is to draw a closed loop to a circuit. Once done with it, draw the direction of the flow of current.

Step 2:

Defining our sign convention is very important

Step 3:

Using Kirchhoff's first law, at B and A, we get: $I_1+I_2=I_3$

Step 4:

By making use of the above convention and Kirchhoff's Second Law,

From Loop 1 we have:

$$E_1 - V_1 - V_3 = 0 \Rightarrow E_1 = V_1 + V_3$$

$$E_1 = R_1 I_1 + R_3 I_3 \Rightarrow 10 = 10 I_1 + 40 I_3 \Rightarrow 1 = I_1 + 4 I_3$$

From Loop 2 we have:

$$E_2 - V_2 - V_3 = 0 \Rightarrow E_2 = V_2 + V_3$$

$$20 = R_2 I_2 + R_3 I_3 \Rightarrow 20 = 20 I_2 + 40 I_3 \Rightarrow 1 = I_2 + 2 I_3$$

By making use of Kirchhoff's First law:

$$I_1 + I_2 = I_3$$

Equation reduces as follows (from Loop 1):

$$1 = 5 I_1 + 4 I_2$$

Equation reduces as follows (from Loop 2):

$$1 = 2 I_1 + 3 I_2$$

This results in the following Equation:

$$I_1 = -1/3 I_2$$

From last three equations we get,

$$1 = 1/3 I_2 + 2 I_2$$

$$I_2 = 0.429 \text{ A}, \quad I_1 = 0.143 \text{ A}, \quad I_3 = 0.286 \text{ A}$$

Exercise 2

For finding Thevenin's equivalent circuit, steps are as follows:

To find R_{Th}

The load resistance R_L is removed. The voltage source is shorted (short-circuited) as shown. The equivalent resistance across AB = Thevenin's resistance R_{Th} .

$$R_{Th} = R_3 + (R_1 // R_2)$$

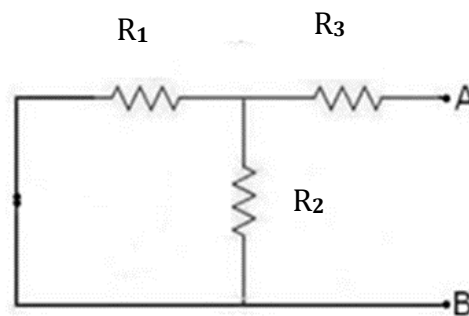

$$R_{Th} = 10 + \frac{2 \times 6}{2 + 6}$$

$$R_{Th} = 11.5 \Omega$$

To find E_{Th}

The load resistance R_L is removed.

The voltage across AB = Thevenin's voltage E_{Th} .

we have:

$$V_{AB} - R_3 \times 0 - R_2 \times I = 0$$

$$E_{Th} = V_{AB} = R_2 \times I$$

with:

$$I = \frac{E}{R_1 + R_2} = 2A$$

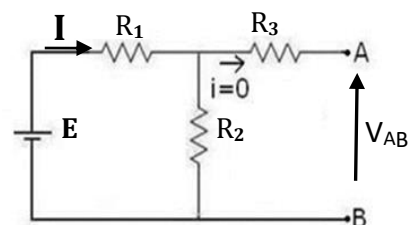

$$E_{Th} = 12V$$

Now, Thevenin's equivalent circuit is:

For which :

$$I_L = \frac{E_{Th}}{R_{Th} + R_L} = \frac{12}{11.5 + 4}$$

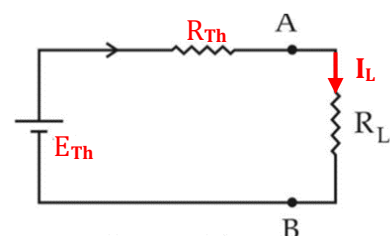

$$I_L = 0.774A$$

and

$$V_L = I_L \times R_L = 0.774A \times 4\Omega$$

$$V_L = 3.096V$$

Exercise 3

the equivalent resistance R_{Th} :

$$R_{Th} = R_{AB} = R1 // R3 = \frac{10 \times 20}{10 + 20}$$

$$R_{Th} = 6.67\Omega$$

The voltage source E_{Th} :

We have

$$E2 - (R3 + R1) \times I - E1 = 0$$

$$I = \frac{E2 - E1}{R3 + R1} = \frac{20 - 10}{20 + 10}$$

$$I = 0.33A$$

And

$$E2 - R3 \times I - V_{AB} = 0$$

$$V_{AB} = E2 - R3 \times I = 20 - 20 \times 0.33$$

$$V_{AB} = 13.4V$$

$$E_{Th} = 13.4V$$

$$I_{AB} = I_2 = \frac{E_{Th}}{R_{Th} + R_2} = \frac{13.4}{6.67 + 40}$$

$$I_{AB} = I_2 = \frac{13.4}{6.67 + 40}$$

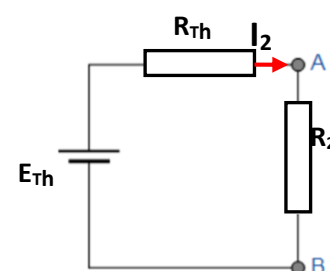
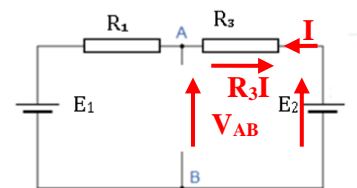
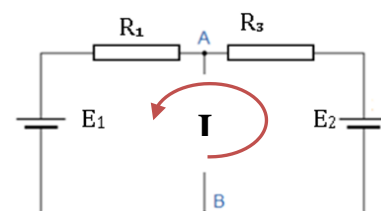

$$I_2 = 0.287A$$

$$V_{AB} = R_2 \times I_2 = 40 \times 0.287$$

$$V_{AB} = 11.48V$$

Chapter 4

Electromagnetism

PIERRE SIMON LAPLACE (1749–1827)



THE FRENCH mathematician and astronomer Pierre Simon Laplace used complex mathematical techniques to show that apparent irregularities in the movements of the Moon and the planets were in fact part of a very long, regular cycle. This showed that the Solar System is indeed stable, as predicted by **Newton's** laws of gravitation and motion. Laplace made many valuable contributions to **mathematical analysis** in the course of this work.

Laplace's contributions to physics, particularly in the mathematical basis of the subject, have had a lasting impact, and his theory of the origin of the Solar System, the so-called **nebular hypothesis**, was accepted for many years.

Hendrik Antoon Lorentz

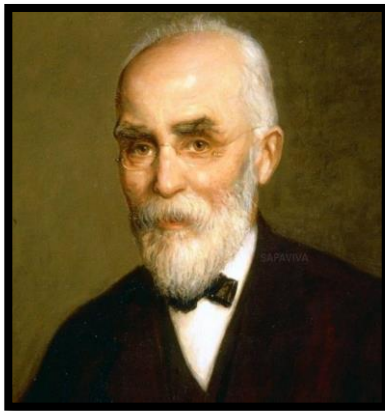

(18 July 1853 – 4 February 1928) was a Dutch physicist who shared the 1902 Nobel Prize in Physics with Pieter Zeeman for the discovery and theoretical explanation of the Zeeman effect. He derived the Lorentz transformation of the special theory of relativity, as well as the Lorentz force, which describes the combined electric and magnetic forces acting on a charged particle in an electromagnetic field. He received many other honours and distinctions, including a term as chairman of the International Committee on Intellectual Cooperation, the forerunner of UNESCO,

IV.1. Introduction

The Greeks knew that certain stones attracted small pieces of iron, and as these stones came from Magnesia (in Turkey), it was called magnetism. These stones are actually natural magnets. Therefore, magnetism designates all the phenomena which take place inside and around magnetic materials. This magnetization can be natural or the result of an induction field. Researchers have noticed that the properties of a magnet are only manifested at its ends: the poles. These two poles, called the north pole and the south pole, are different.

Experience shows that: Two poles of the same name repel each other while two poles of opposite names, attract

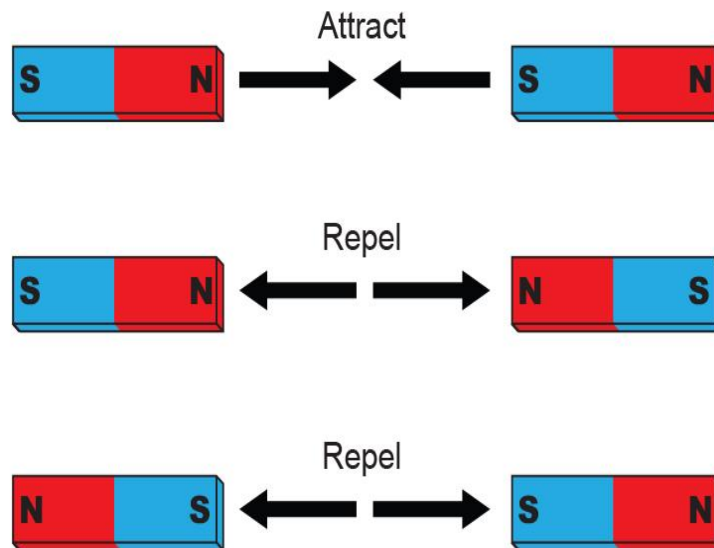

IV.2. Definition

The magnetic field is a vector quantity, which we will designate by \vec{B} (we still say magnetic induction field).

Compared to the electric field, a moving charge or set of charges creates a magnetic field in the region where they are located. This magnetic field acts on an external electric charge q with a force \vec{F}_B . It is the same for an electric current, since by definition, it is a set of charges. The characteristics of the magnetic field:

- The magnetic field vector is tangent to the field lines.

- The magnetic field lines leave the north pole of the magnet and enter through the south pole.
- Unit of the magnetic induction field in the International System is Tesla (T).

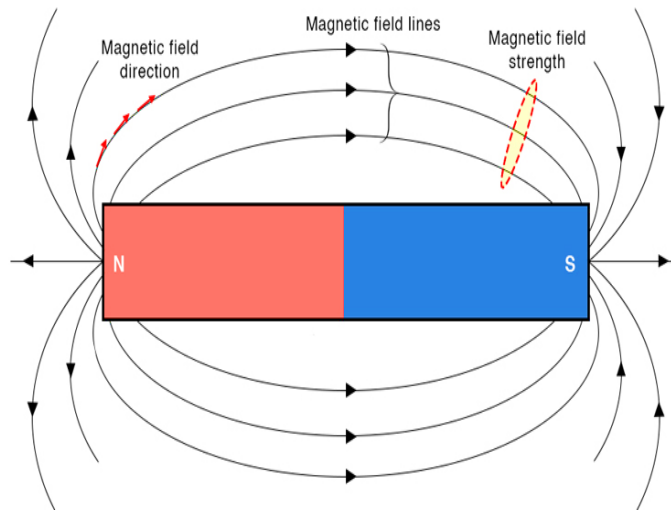

IV.3. Action of a magnetic field on the movement of an electric charge

IV.3.1. Lorentz force

A charge q , moving at speed \vec{v} , subjected to an electric field \vec{E} and magnetic field \vec{B} experiences a force consisting of two parts:

An electrical part, it is the Coulomb force: $\vec{F}_e = q \cdot \vec{E}$

A magnetic part, which is written: $\vec{F}_m = q \cdot \vec{v} \wedge \vec{B}$

The combination of these two forces constitutes the Lorentz force:

$$\vec{F} = q(\vec{E} + \vec{v} \wedge \vec{B})$$

In the presence of the magnetic field alone ($E=0$), the Lorentz force becomes:

$$\vec{F} = q\vec{v} \wedge \vec{B} = q \cdot v \cdot B \cdot \sin\theta \cdot \vec{u}$$

Θ is the angle formed by \vec{v} and \vec{B}

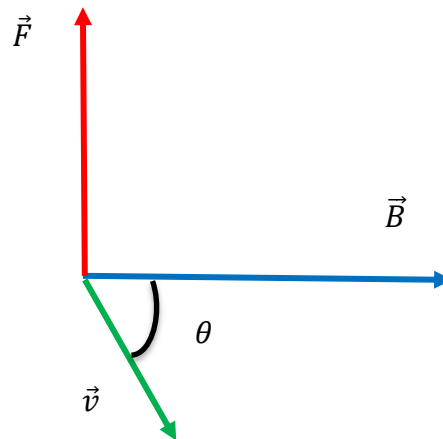

Properties of Lorentz force

- its module: $F = q \cdot v \cdot B \cdot \sin\theta$.
- its direction is perpendicular to the plane formed by \vec{v} and \vec{B}
- Its sense is: in the case of a positive charge, the vectors \vec{F} , \vec{v} and \vec{B} form a direct trihedron (right-hand rule). When the charge is negative the force changes direction.

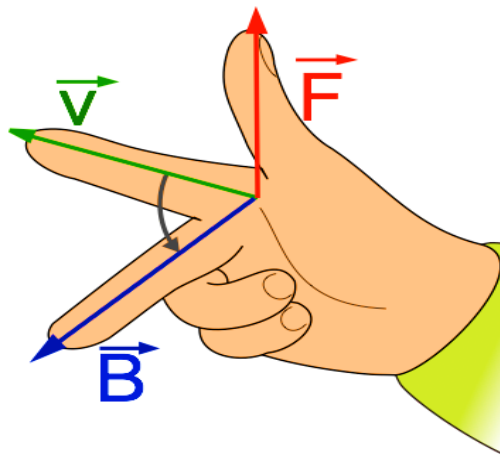

IV.4. action of a magnetic field on an electric current

IV.4.1. Laplace force

When a rectilinear conducting wire of length l , carrying a current I , is placed in a magnetic field B , it experiences a force:

$$\vec{F} = I \cdot \vec{l} \wedge \vec{B}$$

\vec{l} is a vector of length l , parallel to the conductor and oriented in the direction of the current.

The characteristics of the Laplace force are:

- ❑ its module: $F = l \cdot B \cdot |I \cdot \sin\theta|$
- ❑ its direction is perpendicular to the plane formed by \vec{l} and \vec{B} .
- ❑ Its sense is determined by the right-hand rule.

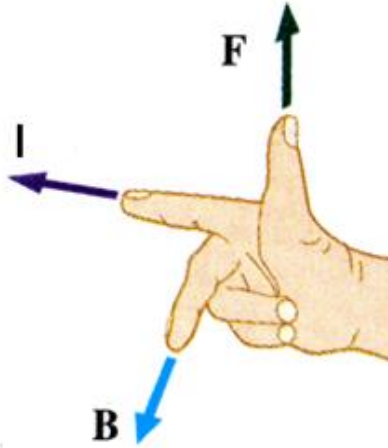

IV.5. Magnetic field created by a current

IV.5.1 Biot and Savart's law

The French physicists Biot and Savart found the expression for the magnetic field obtained during the Oersted experiment.

A rectilinear conducting wire of infinite length, traversed by a current I , creates, at a point M in the space located at a distance r from the wire, a magnetic field including:

- The direction is such that the field lines are circles centered on the wire.
- The meaning is given by the rule of the “good man of Ampère”: this one, when he is traversed by I , from the feet to the head, sees in M the field to his left.
- The module is: $B = \frac{\mu_0 I}{2\pi r}$

μ_0 is the magnetic permeability of vacuum.

In the SI system, $\mu_0 = 4\pi \cdot 10^{-7}$ henry per meter: H/m

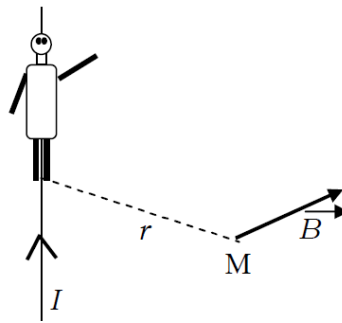

In general:

each current element $I dl$, creates in M an elementary field:

$$d\vec{B} = \frac{\mu_0}{2\pi} \frac{I \cdot d\vec{l} \wedge \vec{u}}{r^2}$$

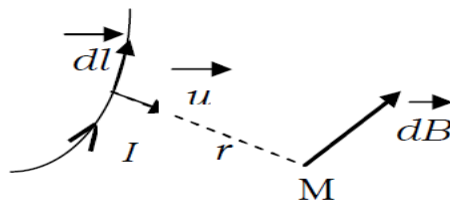

IV.6. Ampère's theorem

Ampère's theorem is the "equivalent" of Gauss's theorem. It makes it possible to calculate the magnetic field created by a current distribution when it has "strong" symmetries.

Statement of Ampère's theorem:

We consider a certain number of wires carried by currents of intensities I_1, I_2 , etc. Let (C) be an oriented closed curve entwining some of these currents and \vec{n} be the normal vector deduced from the right-hand rule.

$$\oint_C \vec{B} \cdot d\vec{r} = \mu_0 \sum_i I_i$$

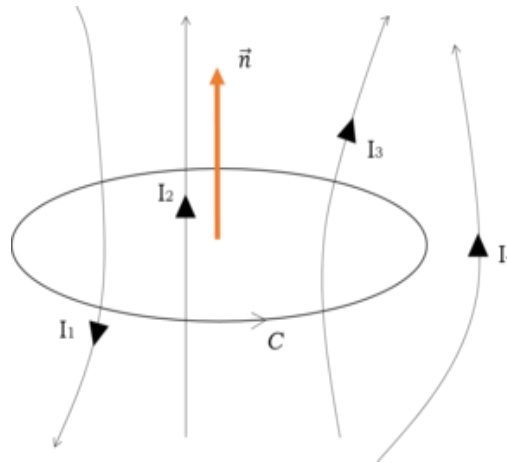

IV.7. Faraday's law

In any closed circuit immersed in a magnetic field, an electromotive force of induction (e) is created equal to the derivative of the magnetic flux, through the circuit, with respect to time (that is to say equal to the speed of variation of the flow) with change of sign:

$$e = -\frac{d\phi}{dt}$$

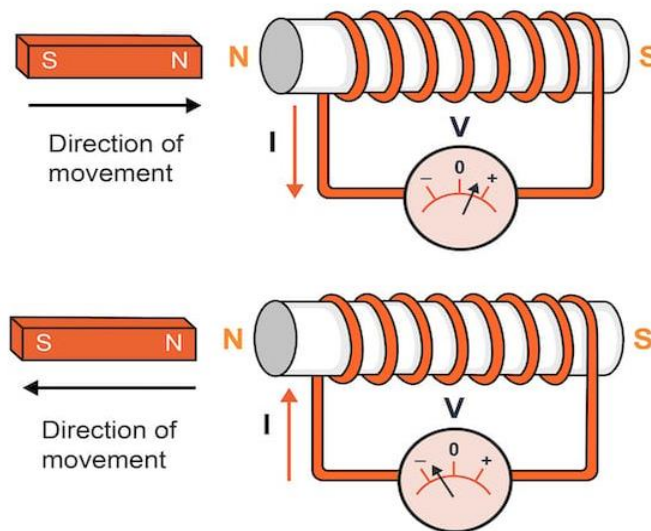

IV.8. Lenz's law

This law allows the determination of the direction of the induced current

Statement

“The direction of the induced current is such that its effects oppose the cause which gave rise to it”.

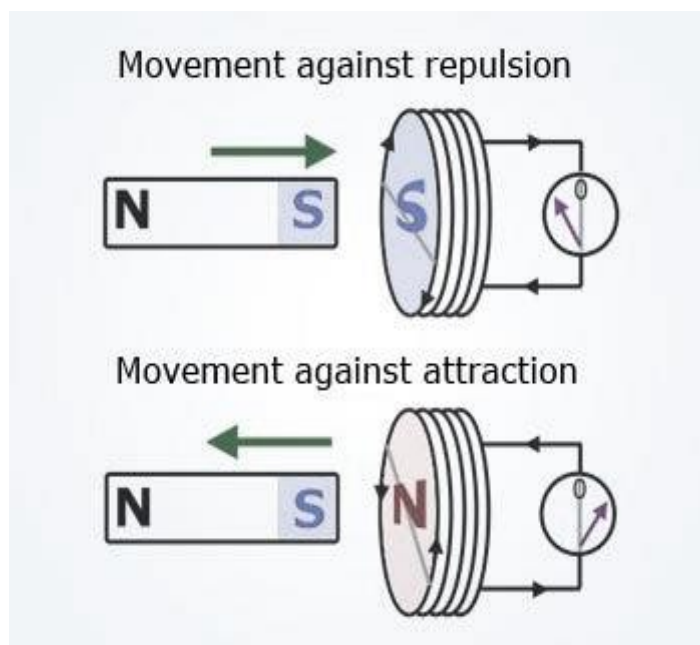

Exercises

Exercise 1

A particle of mass $5 \cdot 10^{-4}$ kg carries a charge of $2.5 \cdot 10^{-8}$ C. The particle is given an initial horizontal speed of $6 \cdot 10^4$ ms⁻¹.

-What is the magnitude and direction of the minimum magnetic field that will keep the particle on a horizontal trajectory by compensating for the effect of gravity?

Solution

Exercise 1

We know that the magnetic force experienced by a charged particle moving with velocity v in a magnetic field B is given by:

$$\vec{F} = q\vec{v}\wedge\vec{B} = q \cdot v \cdot B \cdot \sin\theta \cdot \vec{u}$$

Where q is the charge of the particle.

such that its intensity is equal to:

$$F = q \cdot v \cdot B \cdot \sin\theta$$

With $\theta = (\vec{v}, \vec{B}) = -\pi$.

To keep the particle on a horizontal trajectory, the magnetic force must exactly balance the gravitational force acting on the particle. The gravitational force is given by:

$$F_g = mg$$

Where m is the mass of the particle and g is the acceleration due to gravity.

For the particle to move horizontally, the magnetic force F must be equal in magnitude and opposite in direction to the gravitational force F_g . Thus, we have:

$$mg = q \cdot v \cdot B$$

Solving for B , we get:

$$B = \frac{mg}{q \cdot v}$$

Given:

- $m=5.10 \times 10^{-4}$ kg
- $q=2.5 \times 10^{-8}$
- $v=6.10^4$ m/s
- g (acceleration due to gravity) is approximately 9.81 m/s²

Substitute these values into the equation to find B :

$$B=3.2792 \times 10^{-2} \text{ T}$$

So, the magnitude of the minimum magnetic field required to keep the particle on a horizontal trajectory is approximately 3.2792×10^{-2} T.

As for direction, the magnetic field must be perpendicular to both the velocity of the particle and the gravitational force acting on it. Since the particle is moving horizontally, the magnetic field should be either upward or downward to counteract the downward gravitational force.

BIBLIOGRAPHY

BIBLIOGRAPHY

1. E. Amzallag, j. Cipriani, j. Ben aïm, N. Piccioli, *La physique en fac, Électrostatique et Électrocinétique*, Cours et exercices corrigés, Dunod, Paris, 2006.
2. René Lafrance, Jean Parent, *Physique 2 électricité et magnétisme, 5ed*, De Boeck, 2014
3. D. Cordier, *Cours de Physique pour la Licence- Électromagnétisme*, Dunod (2007).
4. Ahmed Fizazi, *Electricité-Magnétisme, Cours Simplifiés 80 Exercices Corrigés*, Univ-BECHAR