

Badji Mokhtar University –Annaba
Faculty of Sciences
Physics Department



Mechanics of the material point

Courses and exercises

*First-year LMD Sciences and Technology (ST)
and Matter Sciences (MS)*

DRABLIA Samia

2023/2024

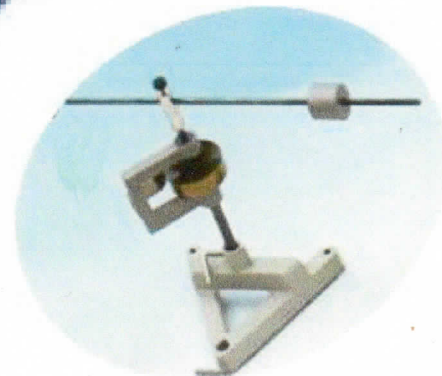



Badji Mokhtar University -Annaba
Faculty of Sciences
Physics Department



Mechanics of the material point

Courses and exercises

***First-year LMD students in Science and Technology (ST)
and Matter Science (MS).***

DRABLIA Samia

2023/2024

Introduction

This course is aimed at students in the core areas (first year) of science and technology (ST), material sciences (SM), mathematics and computer science (MI).

These courses introduce basic concepts of material point mechanics in physics. This handout is made up of 4 chapters consistent with the programs for the first semester.

We'll start by presenting a mathematical reminders ,where in the first part we will we will study dimensional analysis while in the second part, we will focus on the vector calculation.

The first chapter is dedicated to the kinematics of the material point. The objective of this chapter is to describe the movement of the material point in the different coordinate systems. The study of compound movement was studied in this chapter.

The second chapter deals with the dynamics of the material point, within the framework of Newton's mechanics laws.

The last chapter concerns work and energy. We deal with the work of a force, kinetic energy, potential energy, mechanical energy and the conservative forces.

To achieve a correct understanding of the lessons, we have included with each chapter a set of exercises with the typical and detailed solution.

Contents

<u>Mathematical reminders</u>	1
<u>Part 1 :Dimensional equations</u>	2
1.1. Generalities about Physical Quantities	3
1.1.1. Fundamental (Basic) quantities	3
1.1.2. Derived Quantities	3
1.2. System of unit	3
1.3. Dimensional equations	4
1.3.1. Dimension	4
1.3.2. Dimensional equations	5
1.3.3. Homogeneity of dimensions	6
1.3.4. Conversion from SI to CGS	6
Exercises	8
Solution	9
<u>Part 2: Vector Calculus</u>	13
2. 1. Scalar quantities and vector quantities	14
2.2. Vectors	14
2.2.1. Definition	14
2.2.2. Unit vector	14
2.3. Vector snoitarepO	15
2.3.1. The sum (addition) of the vectors	15
2.3.1.1. Properties	15
2.3.2. Vector subtraction	16

2.3.3. Components of a vector	16
2.3.3.1. Linear reference frame	16
2.3.3.2. Planar (two-dimensional) orthogonal reference frame	17
2.3.3.3. An orthonormal reference in space	18
2.3.4. Magnitude (norm) of a vector	19
2.3.5. Scalar (dot) product	19
2.3.5.1. Properties	19
2.3.5.2. Projection of the vector	20
2.3.5.3. Vector projection of vector	20
2.3.6. Direction cosines	21
2.3.7. Vector (cross) product	21
2.3.7.1. Properties	21
2.3.7.2. Magnitude of the cross product	22
2.3.8. Mixed product	22
2.3.8.1. Properties	23
2.3.9. Triple product	23
2.4. Moment of a vector	23
2. 4.1. Moment of a vector relative to a point	23
2. 4.2. Moment of a vector relative to an axis	24
2.5. Vector derivatives	24
2.5.1. Properties	24
2.6. Vector analysis	24
2.6.1. “Nabla” operator	24
2.6.1.1. “Gradient” operator	25
2.6.1.2. “Divergence” operator	25
2.6.1.3. “Curl” operator	25

2.6.1.4. “Laplacian” operator	25
Exercises	26
Solution	28
<u>Chapter 1: Kinematics of a particle</u>	35
I.1. Introduction	36
I.2. Definitions	36
I.2.1. Particle	36
I.2.2. Trajectory	36
I.2.3. noitom fo noitauqE	36
I.3. Movement characteristics	36
I.3.1. Position vecteur	37
I.3.2. Velocity vector	37
I.3.2.1. Average velocity vector	38
I.3.2.2. Instantaneous velocity vector	38
I.3.3. Accélération vector	39
I.3.3.1. Average acceleration vector	39
I.3.3.2. Instantaneous acceleration vector	39
I.4. Coordinate metsys	40
I.4.1. setanidrooc naisetraC	40
I.4.1.1. Position vector	40
I.4.1.2. Velocity vector	40
I.4.1.3. Accélération vector	41
I.4.2. setanidrooc raloP	41
I.4.2.1. Position vector	42

I.4.2.2. Velocity vector	42
I.4.2.3. Accélération vector	42
I.4.3. setanidrooc lacirdnilyC	43
I.4.2.1. Position vector	43
I.4.2.2. Velocity vector	43
I.4.2.3. Accélération vector	44
I.4.4. setanidrooc lacirehpS	44
I.4.4.1. Position vector	44
I.4.4.2. Velocity vector	45
I.4.4.3. Accélération vector	45
I.4.5. Frenet frame (Intrinsic basis)	46
I.4.5.1. Curvilinear abscissa	47
I.4.5.2. Velocity vector in the Frenet reference frame	47
I.4.5.3. Acceleration vector in the Frenet reference frame	47
I.5. Types of movement	48
I.5.1. Rectilinear Movement	48
I.5.1.1. Uniform rectilinear movement	49
I.5.1.2. Uniformly varied rectilinear movement	49
I.5.2. Circular movement	51
I.5.2.1. Uniform circular movement	52
I.5.2.2. Uniformly varied circular movement	52
I.6. Relative motion	52
I.6.1. Change of frames of reference	52
I.6 2. dohtem tceriD	53
I.6 2.1. Position vector	53
I.6 2.2. yticolev etulosbA vector	53

I.6.2.3. Absolute velocity vector	53
I.6.3. compound movement	54
I.6.3.1. isospeed vector	54
I.6.3.2. Absolute velocity vector	54
I.6.3.2. absolute velocity vector	55
Exercises	57
Solution	59
<u>Chapter 2: Dynamics of a particle</u>	66
II.1. Introduction	67
II.2. Definition	67
II.2.1. Concept of force	67
II.2.2. Mass	67
II.2.3. Material point	57
II.2.4. Isolated or pseudo-isolated system	68
II.3. Momentum	68
II.3.1 Conservation of quantity of movement	68
II.3.2. Case of two particles in collision	69
II.4. Fundamental Laws of Dynamics	69
II.4.1. 1st Newton's law 'Principle of Inertia'	69
II.4.2. 2nd Newton's Law: 'Fundamental Relation of Dynamics (FRD)'	70
II.4.3. 3rd Newton's Law: 'Principle of reciprocal actions'	71
II.5. Classification of forces	72
II.5.1. Forces at a distance	72
II.5.2. Contact forces	74

II.6. Cinematic moment (Angular momentum)	76
II.6.1. Angular momentum of a material point	76
II.6.2. Angular momentum theorem	76
II.6.3. Conservation of angular momentum – central forces	77
II.6.4. Inertia forces or pseudo forces: a non-Galilean frame reference	78
Exercises	79
Solution	82
<u>Chapter 3: Work and Energy</u>	91
III.1. Work	92
III.1.1. Elementary work	92
III.2. Constant force on a rectilinear movement	93
III.3. Power	94
III.4. Kinetic energy	94
III.4.1. Kinetic energy theorem	95
III.5. Potential Energy	95
III.5.1. Conservative force and non-conservative force	95
III.6. Potential energy	96
III.7. Total Mechanical Energy	96
III.7.1. Principle of Conservation of Mechanical Energy	96
III.7.2. Examples of conservative forces	97
Exercises	99
Solution	100
Bibliography	105

Mathematical reminders

Part 1

Dimensional equations

1.1. Generalities about Physical Quantities عموميات عن المقادير الفيزيائية

A Physical Quantity is a property that can be measured or calculated, and usually equals a value followed by a unit.

Example : mass ($m=5$ kg), time ($t=12$ h)

There are two types of physical quantities: fundamental quantities and derived quantities.

1.1.1. Fundamental (Basic) quantities المقادير الأساسية

Any physical quantity can be expressed on the basis of the fundamental quantities.

The seven basic quantities are given in Table 1:

Table1. The seven fundamental quantities

Physical quantity	Symbol
Length	l (x, d)
Mass	m
Time	t
Electric current	i
Temperature	T
Luminous intensity	j (I_v)
Amount of substance	n

1.1.2. Derived Quantities المقادير المشتقة

These quantities are expressed as a combination of the seven fundamental quantities (multiplication, division, etc.).

Examples:

- Area (surface) S: $S = l \times l = l^2$, (Unit m^2).
- Velocity v: $v = l/t$. (Unit m/s).
- Force F: $F = m a = m(v/t) = m(l/t^2)$, (Unit: Newton N = $kg\ m/s^2$).

1.2. System of units نظام الوحدات

A physical quantity can be defined by a numerical value which translates its intensity and also its unit, which specifies the nature of this quantity. The four fundamental units thus chosen define the MKSA system whose initials mean meter,

kilogram, second and ampere respectively. The international system of units SI comprises seven basic units and two additional units: meter, kilogram, second, ampere, kelvin, mole and candela. (One can add a complementary unit: the angles, one assigns to a plane angle the radian unit).

All other units called derived units are obtained by combining these basic units of the international system.

Remark:

Before the adoption of the MKSA system, another system in which the length was measured in centimeters, the mass in grams and the time in seconds already existed, is the CGS system (C=centimeter, g=gram and s=second).

1.3. Dimensional equations معادلات الأبعاد

1.3.1. Dimension البعد

The nature of a physical quantity is recognized by its dimension. The dimension of a physical quantity G is noted by the expression $[G]$. For example, if G has the dimension of a length, it is said to be homogeneous to a length, so the relation $[G] = L$ corresponds to the equation to the dimensions (the dimension) of the quantity G .

So if G is the size of a:

- mass, note $[G]=M$,
- length, note $[G]=L$,
- time, note $[G]=T$,
- electric current, note $[G]=I$,
- temperature, note $[G]=\theta$,
- luminous intensity, note $[G]= J$,
- quantity of substance, note $[G]= N$.

The dimension and unity must therefore be coherent with each other. A quantity has a single dimension but can be expressed in several units.

For example, the mass has the dimension M and can be expressed in kg or g.

The length has the dimension L and can be expressed in m or cm.

The time has the dimension T and can be expressed in s.

Table 2. dimension of fundamental quantities and their units in the SI system

Basic size	Dimension	Unit Name (SI)	unit symbol (SI)
Length	L	meter	m
Mass	M	kilogram	kg
Time	T	second	s
Electric current	I	ampere	A
Temperature	θ	kelvin	K
Amount of substance	N	mole	mol
Luminous intensity	J	candela	cd
Flat angle	A	radian	rad
Solid angle	Ω	steradian	sr

1.3.2. Dimensional equations معادلات الأبعاد

A dimensional equation is a mathematical relationship that expresses the dimension of a physical quantity as a function of the dimensions of the fundamental quantities. Generally, the dimension of a derived quantity is expressed by the product of powers of the fundamental dimensions. The dimensional equation of a derived physical quantity G is written:

$$[G] = M^{\alpha} L^{\beta} T^{\gamma} I^{\sigma}$$

The dimensional equations allows to:

- Determine the unit composed of a quantity according to the fundamental quantities.
- Check if a formula is homogeneous and detect errors in calculations.
- Perform unit conversions.

Example:

$$\text{velocity: } v = \frac{x}{t}$$

$$\text{The velocity dimension: } [v] = \left[\frac{x}{t} \right] = \frac{[x]}{[t]} = \frac{L}{T} = LT^{-1}$$

So, the of velocity dimensional equation: $[v] = LT^{-1}$ and the unit in SI: m.s^{-1}

Some of quantities are reported in the table 2 where the equivalent units are specified in the International System of Units (SI).

Table 3. Dimensional equations of derived quantities and their units in SI

Derived quantity	The expression	dimensional equation	IS Unit	Commonly used unit
Acceleration	$a=l/t^2$	LT^{-2}	$m.s^{-2}$	
Force	$F=ma$	MLT^{-2}	$Kg.m.s^{-2}$	newton (N)
Pressure	$p=F/S$	$ML^{-1}T^{-2}$	$kg.m^{-1}.s^{-2}$	pascal (Pa)
Energy, Work	$W=Fl$	ML^2T^{-2}	$kg.m^2.s^{-2}$	joule (J)
Power	$P=W/t$	ML^2T^{-3}	$kg.m^2.s^{-3}$	watt (W)
Electric charge	$Q=it$	IT	A.S	coulomb (C)
Electric field	$E=F/q$	$MLT^{-3}I^{-1}$	$kg.m.s^{-3}.A^{-1}$	Volt/meter (V/m)
Potential (voltage)	$U=El$	$ML^2T^{-3}I^{-1}$	$kg.m^2.s^{-3}.A^{-1}$	volt (V)
Electrical capacity	$C=q/U$	$M^{-1}L^{-2}T^4I^2$	$Kg^{-1}.m^{-2}.s^4.A^2$	farad (F)
Resistance	$R=U/i$	$ML^2T^{-3}I^{-2}$	$kg.m^2.s^{-3}.A^{-2}$	ohm (Ω)

Note:

The functions: $\sin(x)$, $\cos(x)$, $\tan(x)$, $\ln(x)$, $\log(x)$ and e^x are dimensionless (without dimensions), so $[\sin(x)] = [\cos(x)] = [\tan(x)] = [e^x] = [\ln(x)] = [\log(x)] = 1$.

Also, a constant is dimensionless ($[\pi] = 1$).

1.3.3. Homogeneity of dimensions تجانس الأبعاد

Dimensional equations are used to verify the homogeneity of formulas, that is, both its members have the same dimension.

1.3.4. Conversion from SI to CGS

Table 4 summarizes some conversions from SI to CGS

Table 4. Conversion from SI to CGS

Quantity	IS Unit	Symbol	CGS Unit	Symbol	Equivalence
length	m	m	cm	cm	$1\text{m}=10^2\text{cm}$
mass	kg	kg	g	g	$1\text{kg}=10^3\text{g}$
time	s	s	s	s	
acceleration	m.s^{-2}	m.s^{-2}	cm.s^{-2}	Gal	$1\text{m.s}^{-2}=10^2\text{cm.s}^{-2}$ ($1\text{m.s}^{-2}=10^2\text{Gal}$)
force	Kg.m.s^{-2}	N (newton)	g.cm.s^{-2}	Dyn (dyne)	$\text{Kg.m.s}^{-2}=10^5\text{g.cm.s}^{-2}$ ($1\text{N}=10^5\text{dyn}$)
energy	$\text{Kg.m}^2\text{s}^{-2}$	J (joule)	$\text{g.cm}^2\text{s}^{-2}$	erg	$\text{kg.m}^2\text{s}^{-2}=10^7\text{g.cm}^2\text{s}^{-2}$ ($1\text{J}=10^7\text{erg}$)
pressure	$\text{Kg.m}^{-1}\text{s}^{-2}$	Pa (pascal)	$\text{g.cm}^{-1}\text{s}^{-2}$	Ba (barye)	$\text{Kg.m}^{-1}\text{s}^{-2}=10\text{g.cm}^{-1}\text{s}^{-2}$ ($1\text{Pa}=10\text{Ba}$)

Exercises

Exercise 1

Write the dimensional equations of the following quantities and deduce their units in the international system (IS):

1. The pressure $P = \frac{F}{S}$
2. The quantity of movement $\vec{P}: \left(\vec{F} = \frac{d\vec{P}}{dt}\right)$
3. The momentum of $\vec{F}: \vec{\mathcal{M}}_{/O}(\vec{F}) = \vec{r} \wedge \vec{F}$
4. The angular momentum $\vec{L} = \vec{r} \wedge \vec{P}$
5. The electric field $E = F/q$
6. The electric potential $V = E \cdot l$

Exercise 2

The T -period of a circular Earth satellite may depend on the mass of the Earth m , the radius of the circle described R and the constant of the universal gravitation G .

We will write: $T = k \cdot m^a \cdot R^b \cdot G^c$, where k is a dimensionless constant.

- Determine by a dimensional analysis the values of a , b and c . Deduce the expression of the formula of the period T .

Exercise 3

Experience has shown that the force experienced by a sphere immersed in a moving fluid depends on:

- The viscosity coefficient η of the fluid.
- The radius of the sphere R .
- Their relative speed v .

Find the expression for this force by assuming the form: $F = k\eta^a R^b v^c$

(k is a dimensionless numerical coefficient). We recall that $[\eta] = L^{-1}MT^{-1}$.

Solution

Exercise 1

1. Pressure (P):

$$P = \frac{F}{S}$$

$$[P] = \frac{[F]}{[S]} = \frac{[F]}{[S]}$$

F : force :

$$F = ma \text{ and } a = \frac{v}{t} = \frac{\frac{x}{t}}{t} = \frac{x}{t^2}$$

$$F = m \frac{x}{t^2}$$

$$\text{So } [F] = [m] \frac{[x]}{[t^2]} = M \cdot \frac{L}{T^2} = M \cdot L \cdot T^{-2}$$

S : area :

$$S = l^2$$

$$\text{So } [S] = L^2$$

$$[P] = \frac{[F]}{[S]} = \frac{M \cdot L \cdot T^{-2}}{L^2}$$

$$\boxed{[P] = M \cdot L^{-1} \cdot T^{-2}}$$

Unit of pressure in IS : $\text{kg} \cdot \text{m}^{-1} \cdot \text{s}^{-2} = \text{pascals (Pa)}$

$$1 \text{ Pa} = 1 \text{ N/m}^2$$

2. Quantity of movement \vec{P} :

$$\vec{F} = \frac{d\vec{P}}{dt}$$

$$\vec{F} = \frac{d\vec{p}}{dt} \Rightarrow d\vec{p} = \vec{F} \cdot dt = m \cdot \vec{a} \cdot dt.$$

$$\Rightarrow p = \int m \cdot a \cdot dt = m \int \frac{dv}{dt} dt = m \int dv = mv$$

$$\text{So } p = mv \Rightarrow [p] = [mv] = [m][v] = [m] \left[\frac{x}{t} \right] = M \cdot \frac{L}{T}$$

$$\boxed{[p] = M \cdot L \cdot T^{-1}}$$

Unit of quantity of movement in IS: $\text{kg}\cdot\text{m}/\text{s}$.

3. The momentum of force \vec{F} :

$$\vec{\mathcal{M}}_{/O}(\vec{F}) = \vec{r} \wedge \vec{F}$$

$$M_{/O}(\vec{F}) = r \cdot F \Rightarrow [M] = [r] \cdot [F] = L \cdot M \cdot L \cdot T^{-2}$$

$$\boxed{M \cdot L^2 \cdot T^{-2} = [M]}$$

Unit of momentum of a force in IS: $\text{kg}\cdot\text{m}^2/\text{s}^2 = \text{joule (J)}$

4. The angular momentum $\vec{\mathcal{L}}$:

$$\vec{\mathcal{L}} = \vec{r} \wedge \vec{p} \quad (\mathbf{p} \text{ is a quantity of movement})$$

$$\vec{\mathcal{L}} = \vec{r} \wedge \vec{p} = \vec{r} \wedge m\vec{v} \Rightarrow \mathcal{L} = r \cdot m \cdot v \Rightarrow [p] = [r][m][v] = [r][m] \left[\frac{x}{t} \right]$$

$$\boxed{[L] = M \cdot L^2 \cdot T^{-1}}$$

Unit of angular momentum in IS: $\text{kg}\cdot\text{m}^2/\text{s}$

5. Electric Field (E):

$$E = \frac{F}{q}$$

$$[E] = \frac{[F]}{[q]}$$

$$\Rightarrow [F] = M \cdot L \cdot T^{-2}$$

q: charge électrique: $q = it \Rightarrow [q] = [i] \cdot [t] = IT$

$$[E] = \frac{[F]}{[q]} = \frac{M \cdot L \cdot T^{-2}}{IT}$$

$$\boxed{[E] = M \cdot L \cdot T^{-3} I^{-1}}$$

Unit of electric field in IS: $\text{kg}\cdot\text{m}\cdot\text{s}^{-3}\cdot\text{A}^{-1} = (\text{V}/\text{m})$.

6. Electric potential (V):

$$V = E \cdot l$$

$$[V] = [E] \cdot [l] = M \cdot L \cdot T^{-3} I^{-1} \cdot L$$

$$\boxed{[V] = ML^2 T^{-3} I^{-1}}$$

Unit of electric potential in IS: $\text{kg}\cdot\text{m}^2\cdot\text{s}^{-3}\cdot\text{A}^{-1} = \text{Volt (V)}$.

Exercise 2

The equation of dimensions for period T is given by the following formula:

$$[T]=[k.m^a.R^b.G^c] = [k]. [m^a]. [R^b]. [G^c] = [m]^a. [R]^b. [G]^c \text{ (k is a dimensionless constant)}$$

The dimension of each term must be determined:

$$[T] = T$$

$$[m] = M$$

$$[R] = L$$

$$[G] = ?$$

So according to the law of universal gravitation :

$$F = G \frac{mm'}{r^2}$$

Or F is the gravitational force between two masses m and m' separated by distance r

$$\Rightarrow G = \frac{Fr^2}{mm'}, \text{ so the dimension of } G \text{ is :}$$

$$[G] = \frac{[F][r]^2}{[m][m']}$$

$$F \text{ is a force: } F=ma \Rightarrow [F] = [m][a] = MLT^{-2}$$

$$[r] = L$$

$$[m] = [m'] = M$$

$$[G] = \frac{MLT^{-2}L^2}{M^2} = M^{-1}L^3T^{-2}$$

Replace $[G]$ in the $[T]$ expression

$$T = M^a L^b (M^{-1}L^3T^{-2})^c = M^{a-c} L^{b+3c} T^{-2c}$$

$$\begin{cases} a - c = 0 \\ b + 3c = 0 \\ -2c = 1 \end{cases} \Rightarrow \begin{cases} a = c \\ b = -3c \\ c = -1/2 \end{cases} \Rightarrow \begin{cases} a = -1/2 \\ b = 3/2 \\ c = -1/2 \end{cases}$$

$$\text{So } T = k.m^{-1/2}.R^{3/2}.G^{-1/2}$$

$$T = kR \sqrt{\frac{R}{mG}}$$

Exercise 3

$$F = k\eta^a R^b v^c \Rightarrow [F] = [k][\eta]^a [R]^b [v]^c$$

The dimensions of the quantities are:

Viscosity coefficient η : $[\eta] = M L^{-1} T^{-1}$

Radius of the sphere R : $[R] = L$

Relative speed v : $[v] = L T^{-1}$

Force F : $[F] = M \cdot L \cdot T^{-2}$

k is a dimensionless numerical coefficient, so $[k] = 1$

$$\Rightarrow [F] = [k][\eta]^a [R]^b [v]^c$$

$$\Rightarrow M \cdot L \cdot T^{-2} = (M L^{-1} T^{-1})^a (L)^b (L T^{-1})^c$$

$$M \cdot L \cdot T^{-2} = (M)^a L^{-a+b+c} T^{-a-c}$$

$$\begin{cases} \boxed{1 = a} \\ 1 = -a + b + c \Rightarrow b = 1 + a - c = 1 + 1 - 1 = \boxed{1 = b} \\ -2 = -a - c \Rightarrow c = -a + 2 = -1 + 2 = \boxed{1 = c} \end{cases}$$

$$\Rightarrow F = k\eta^1 R^1 v^1$$

So, the expression for this force

$$\boxed{F = k\eta R v}$$

Part 2

Vector calculus

2.1. Scalar quantities and vector quantities المقادير السلمية و المقادير الشعاعية

Physical quantities are divided into two groups:

- Scalar quantity such that; mass (m), time (t), energy (E),
- Vector quantity such as velocity (\vec{v}), force (\vec{F}),...

2.2. Vectors الأشعة

2.2.1. Definition: تعريف

A vector is a line segment AB, having an origin A and an end B. We denote it by \overrightarrow{AB} , characterized by:

- Its direction which is defined by that of the line which carries the segment
- Its sense which designates the orientation of the vector (from A towards B).
- Its magnitude (norm or intensity) which is equal to the length of the segment [AB], noted $\|\overrightarrow{AB}\|$ which is always positive.

Note:

A vector can be designated by a single letter: $\overrightarrow{AB} = \vec{V}$.

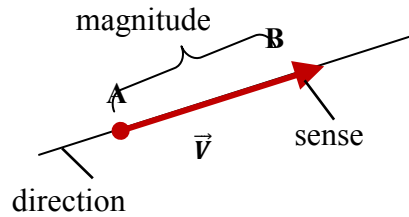

2.2.2. Unit vector شعاع الوحدة

A vector is unitary when its magnitude is equal to unity (1).

If \vec{u} is a unit vector carried by a vector \vec{V} then:

$$\vec{V} = \|\vec{V}\| \cdot \vec{u} \Rightarrow \vec{u} = \frac{\vec{V}}{\|\vec{V}\|}$$

We also have $\|\vec{u}\| = 1$ and \vec{u} is always parallel to \vec{V} ($\vec{u} // \vec{V}$).

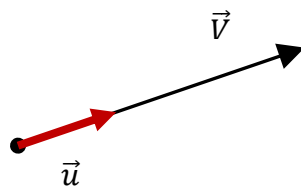

2.3. Vector Operations

Let $\vec{V}_1, \vec{V}_2, \vec{V}_3$, be three vectors, a, b and c real numbers

2.3.1. The sum (addition) of the vectors جمع الأشعة

The sum of two vectors \vec{V}_1 and \vec{V}_2 is another vector \vec{S} , with :

$$\vec{S} = \vec{V}_1 + \vec{V}_2$$

Graphically, we can find the resulting vector \vec{S} by the parallelogram rule.

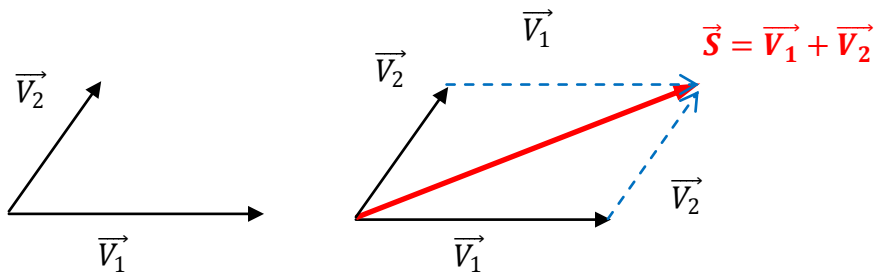

The sum of n vectors: $\vec{V}_1, \vec{V}_2, \vec{V}_3, \dots, \vec{V}_n$. is a vector \vec{S} such that:

$$\vec{S} = \vec{V}_1 + \vec{V}_2 + \vec{V}_3 + \dots + \vec{V}_n$$

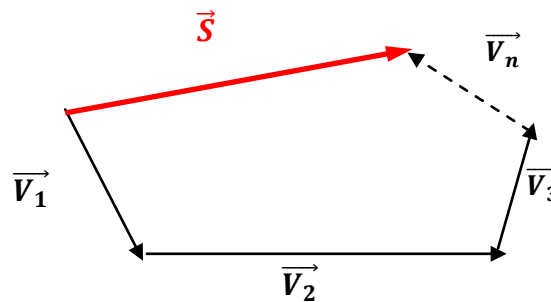

2.3.1.1. Properties: الخواص

* Commutativity (تبديلي): $\vec{S} = \vec{V}_1 + \vec{V}_2 = \vec{V}_2 + \vec{V}_1$

* Associativity (تجميعي): $(\vec{V}_1 + \vec{V}_2) + \vec{V}_3 = \vec{V}_1 + (\vec{V}_2 + \vec{V}_3)$.

* Distributivity (توزيعي) : $(a+b) \cdot \vec{V}_1 = a \cdot \vec{V}_1 + b \cdot \vec{V}_1$

$$\text{and } a \cdot (\vec{V}_1 + \vec{V}_2) = a \cdot \vec{V}_1 + a \cdot \vec{V}_2$$

* The sum of a vector \vec{V}_1 and its opposite $(-\vec{V}_1)$ is zero: $\vec{V}_1 + (-\vec{V}_1) = \vec{0}$

2.3.2. Vector subtraction طرح الأشعة

The difference of two vectors \vec{V}_1 and \vec{V}_2 is a vector \vec{D} , with :

$$\vec{D} = \vec{V}_1 - \vec{V}_2 = \vec{V}_1 + (-\vec{V}_2)$$

Graphically, we can find the resulting vector \vec{D} by the parallelogram rule.

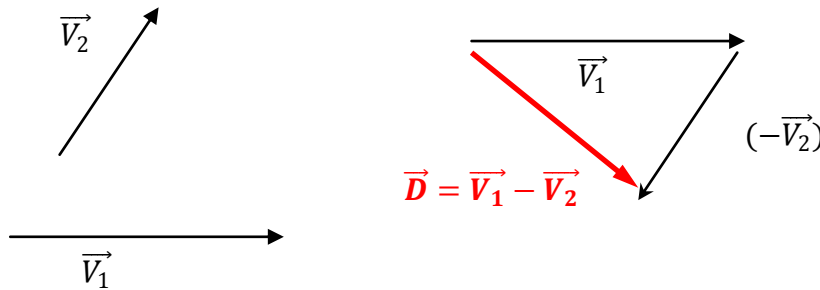

Note:

$\vec{V}_1 - \vec{V}_2 \neq \vec{V}_2 - \vec{V}_1$, therefore the difference of the vectors is non-commutative.

2.3.3. Components of a vector مركبات شعاع

To determine the components of a vector, it is necessary to choose a reference frame (coordinate system) which is a set of non-collinear unit vectors called basis. We can then decompose all the other vectors according to these unit vectors and this decomposition is unique. We have three types of references frame:

2.3.3.1. Linear reference frame: معلم خطي

It is composed of a single axis Ox, provided with a unit vector \vec{i} positively oriented. The coordinate (x) of point M is defined by:

$$\vec{OM} = x\vec{i}$$

(x) is also called the component of the vector \vec{OM} .

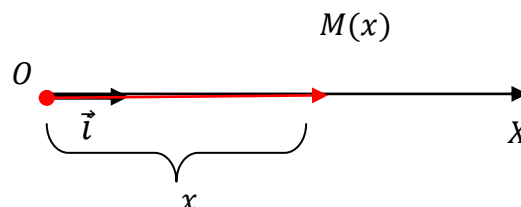

2.3.3.2. Planar (two-dimensional) orthogonal reference frame: معلم مستوي

It is composed of two orthogonal axes of the plane, OX and OY, provided with unit vectors \vec{i} and \vec{j} positively oriented.

The position of a point M is characterized by the vector \overrightarrow{OM} :

$$\vec{V} = \overrightarrow{OM}$$

Let x and y be the projections of M onto the OX and OY axes, respectively. So we have:

$$\vec{V} = x\vec{i} + y\vec{j} = \begin{pmatrix} x \\ y \end{pmatrix}$$

$$\begin{cases} x = \|\vec{V}\|\cos\theta \\ y = \|\vec{V}\|\sin\theta \end{cases}$$

$$\vec{V} = x\vec{i} + y\vec{j} = \|\vec{V}\|\cos\theta\vec{i} + \|\vec{V}\|\sin\theta\vec{j}$$

$$\Rightarrow \vec{V} = \|\vec{V}\|(\underbrace{\cos\theta.\vec{i} + \sin\theta.\vec{j}}_{\vec{u}}) \Rightarrow \vec{V} = \|\vec{V}\|.\vec{u}$$

\vec{u} is the unit vector of the vector \vec{V}

$$\vec{u} = \cos\theta.\vec{i} + \sin\theta.\vec{j}$$

(x,y) is called the components of the vector \vec{V} or the cartesian coordinates of the point M in the plane (OXY)

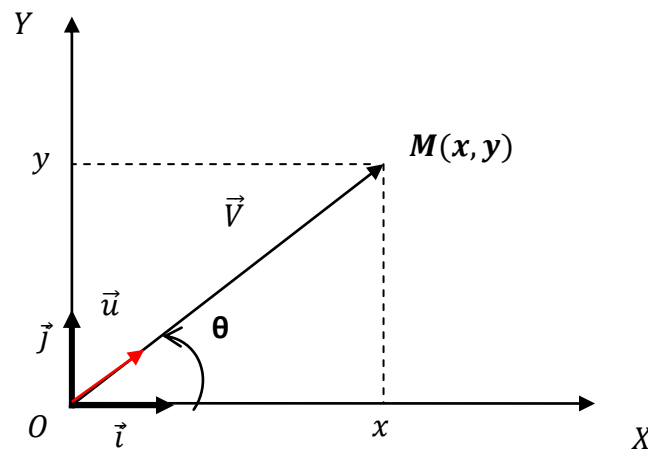

2.3.3.3. An orthonormal reference in space: معلم متعامد متجانس في الفضاء

It is composed of three orthogonal axes, OX , OY and OZ , provided with unit vectors \vec{i}, \vec{j} and \vec{k} positively oriented. The position of a point M in space is characterized by the vector $\vec{V} = \overrightarrow{OM}$. Let x , y and z be the projections of M onto the axes OX , OY and OZ , respectively. So we have:

$$\vec{V} = x\vec{i} + y\vec{j} + z\vec{k} = \begin{pmatrix} x \\ y \\ z \end{pmatrix}$$

$$\begin{cases} x = \|\overrightarrow{OM'}\| \cos\theta \\ y = \|\overrightarrow{OM'}\| \sin\theta \Rightarrow \|\overrightarrow{OM'}\| = \|\vec{V}\| \cdot \sin\varphi \\ z = \|\vec{V}\| \cos\varphi \end{cases}$$

$$\Rightarrow \begin{cases} x = \|\vec{V}\| \sin\varphi \cdot \cos\theta \\ y = \|\vec{V}\| \sin\varphi \cdot \sin\theta \\ z = \|\vec{V}\| \cos\varphi \end{cases}$$

$$\vec{V} = \|\vec{V}\| \cdot \vec{u}$$

\vec{u} is the unit vector of the vector \vec{V}

$$\vec{u} = \sin\varphi \cdot \cos\theta \cdot \vec{i} + \sin\varphi \cdot \sin\theta \cdot \vec{j} + \cos\varphi \cdot \vec{k}$$

(x,y,z) is called the components of the vector \overrightarrow{OM} or the cartesian coordinates of the point M in the orthonormal reference frame $(OXYZ)$.

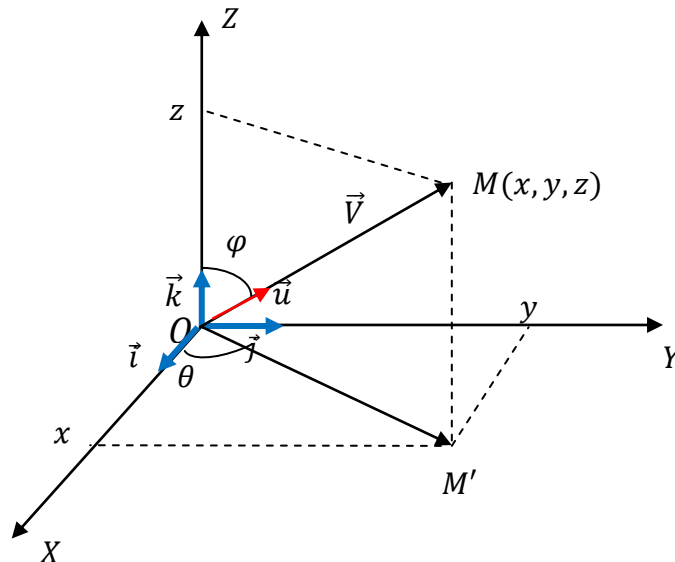

2.3.4. Magnitude (norm) of a vector *طويلة شعاع*

The magnitude of a vector $\vec{V} = x\vec{i} + y\vec{j} + z\vec{k}$ represents its length, it is given by the following formula:

$$\|\vec{V}\| = \sqrt{x^2 + y^2 + z^2} = V$$

$\|\vec{V}\|$ is always positive

2.3.5. Scalar (dot) product *الجداء السلمي*

The dot product of two vectors \vec{V}_1 and \vec{V}_2 is a scalar given by the following relation:

$$\vec{V}_1 \cdot \vec{V}_2 = \|\vec{V}_1\| \cdot \|\vec{V}_2\| \cdot \cos\theta$$

Where θ is the angle between the two vectors \vec{V}_1 and \vec{V}_2

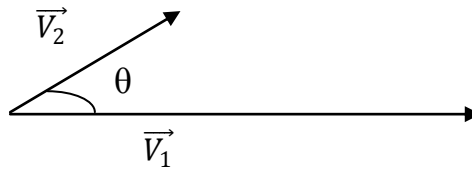

2.3.5.1. Properties

- ❖ $\vec{V} \cdot \vec{V} = \|\vec{V}\| \cdot \|\vec{V}\| \cdot \cos 0 = V^2$
- ❖ $\vec{V}_1 \cdot \vec{V}_2 = \|\vec{V}_1\| \cdot \|\vec{V}_2\| \cdot \cos\theta = \|\vec{V}_2\| \cdot \|\vec{V}_1\| \cdot \cos(\pi - \theta) \Rightarrow \vec{V}_1 \cdot \vec{V}_2 = \vec{V}_2 \cdot \vec{V}_1$
- ❖ $\vec{V}_1 \cdot (\vec{V}_2 + \vec{V}_3) = \vec{V}_1 \cdot \vec{V}_2 + \vec{V}_1 \cdot \vec{V}_3$
- ❖ $(\vec{V}_1 \pm \vec{V}_2)^2 = V_1^2 + V_2^2 \pm 2V_1V_2\cos\theta$
- ❖ If $\theta = \frac{\pi}{2}$, their scalar product is zero:

$$\vec{V}_1 \perp \vec{V}_2 \Rightarrow \vec{V}_1 \cdot \vec{V}_2 = 0$$

We will therefore have:

- ❖ $\vec{i} \cdot \vec{i} = \vec{j} \cdot \vec{j} = \vec{k} \cdot \vec{k} = 1$
- ❖ $\vec{i} \cdot \vec{j} = \vec{j} \cdot \vec{k} = \vec{i} \cdot \vec{k} = 0$
- ❖ If we know the coordinates of two vectors in an orthonormal basis, the scalar product will be expressed only in terms of the coordinates:

$$\vec{V}_1 \begin{pmatrix} x_1 \\ y_1 \\ z_1 \end{pmatrix} \text{ and } \vec{V}_2 \begin{pmatrix} x_2 \\ y_2 \\ z_2 \end{pmatrix} \Rightarrow \vec{V}_1 \cdot \vec{V}_2 = \begin{pmatrix} x_1 \\ y_1 \\ z_1 \end{pmatrix} \cdot \begin{pmatrix} x_2 \\ y_2 \\ z_2 \end{pmatrix}$$

$$\vec{V}_1 \cdot \vec{V}_2 = x_1x_2 + y_1y_2 + z_1z_2$$

2.3.5.2. Projection of the vector: مسقط شعاع

The projection of the vector \vec{V}_2 onto \vec{V}_1 is given by the following relation:

$$proj \vec{V}_2 / \vec{V}_1 = \|\vec{V}_2\| \cdot \cos\theta$$

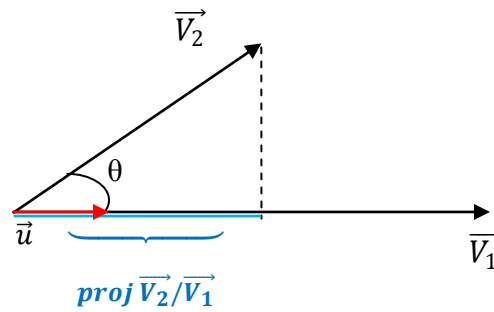

We can rewrite the previous relation in the form of a scalar product:

$$\vec{u} \cdot \vec{V}_2 = \|\vec{u}\| \cdot \|\vec{V}_2\| \cdot \cos\theta = \|\vec{u}\| \cdot proj \vec{V}_2 / \vec{V}_1$$

\vec{u} is the unit vector of the vector \vec{V}_1

$$\Rightarrow \|\vec{u}\| = \frac{\|\vec{V}_1\|}{\|\vec{V}_1\|} = 1$$

$$\Rightarrow proj \vec{V}_2 / \vec{V}_1 = \frac{\vec{V}_1 \cdot \vec{V}_2}{V_1}$$

2.3.5.3. Vector projection of vector: شعاع مسقط شعاع

The vector projection of vector \vec{V}_2 onto \vec{V}_1 is a vector defined by:

$$\overrightarrow{proj} \vec{V}_2 / \vec{V}_1 = proj \frac{\vec{V}_2}{V_1} \cdot \vec{u} = \frac{\vec{V}_1 \cdot \vec{V}_2}{V_1} \cdot \vec{u} = \frac{(\vec{V}_1 \cdot \vec{V}_2)}{V_1} \cdot \frac{\vec{V}_1}{V_1} = \frac{\vec{V}_1 \cdot (\vec{V}_1 \cdot \vec{V}_2)}{V_1^2}$$

$$\overrightarrow{proj} \vec{V}_2 / \vec{V}_1 = \frac{\vec{V}_1 \cdot (\vec{V}_1 \cdot \vec{V}_2)}{V_1^2}$$

2.3.5.3. Direction cosines

The direction cosines of the vector $\vec{V} = x\vec{i} + y\vec{j} + z\vec{k}$ are the cosines of angles that the vector \vec{V} forms with the coordinate axes.

Let α , β and γ be the angles that the vector \vec{V} makes with the axes OX, OY and OZ.

$$\cos \alpha = \frac{V_x}{V}$$

$$\cos \beta = \frac{V_y}{V}$$

$$\cos \gamma = \frac{V_z}{V}$$

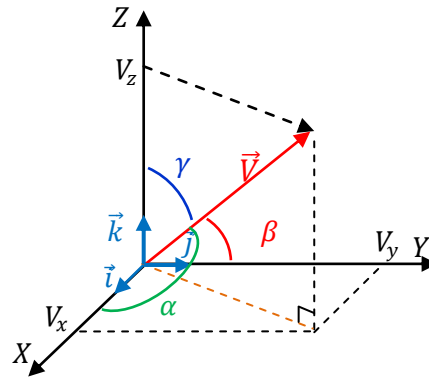

2.3.7. vector (cross) product الجداء الشعاعي

The cross product of two vectors \vec{V}_1 and \vec{V}_2 is another vector \vec{P} perpendicular to the plane which formed by two vectors, it's direction is found by using the right-hand rule. The vector product is defined by:

$$\vec{P} = \vec{V}_1 \wedge \vec{V}_2 = \|\vec{V}_1\| \cdot \|\vec{V}_2\| \cdot \sin\theta \cdot \vec{u}$$

Where \vec{u} is the unit vector perpendicular to plane formed by \vec{V}_1 and \vec{V}_2 .

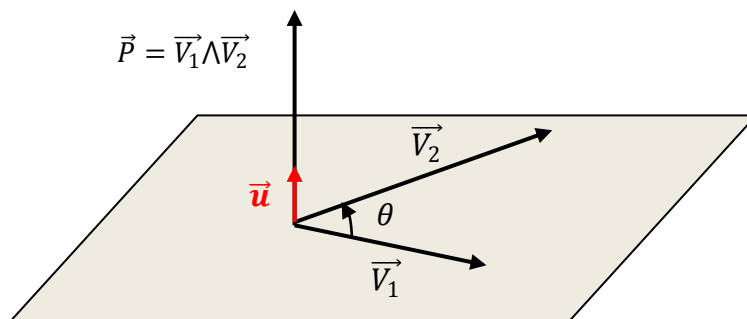

2.3.7. 1. Properties

- ❖ The magnitude of \vec{P} is given by $\|\vec{P}\| = \|\vec{V}_1 \wedge \vec{V}_2\| = \|\vec{V}_1\| \cdot \|\vec{V}_2\| \cdot |\sin\theta|$
- ❖ The cross product is anticommutative: $\vec{V}_1 \wedge \vec{V}_2 = -(\vec{V}_2 \wedge \vec{V}_1)$
- ❖ The cross product is distributive: $\vec{V}_1 \wedge (\vec{V}_2 \pm \vec{V}_3) = \vec{V}_1 \wedge \vec{V}_2 \pm \vec{V}_1 \wedge \vec{V}_3$

- ❖ $\vec{V}_1 \wedge \vec{V}_2 = \vec{0} \Rightarrow \vec{V}_1 // \vec{V}_2$
- ❖ $\vec{i} \wedge \vec{i} = \vec{j} \wedge \vec{j} = \vec{k} \wedge \vec{k} = \vec{0}$ And $\vec{i} \wedge \vec{j} = \vec{k}$, $\vec{j} \wedge \vec{k} = \vec{i}$, $\vec{k} \wedge \vec{i} = \vec{j}$
- ❖ The cross product can be calculated by the determinant method

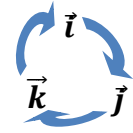

based on the coordinates of $\vec{V}_1 \begin{pmatrix} x_1 \\ y_1 \\ z_1 \end{pmatrix}$ and $\vec{V}_2 \begin{pmatrix} x_2 \\ y_2 \\ z_2 \end{pmatrix}$:

$$\vec{V}_1 \wedge \vec{V}_2 = \begin{vmatrix} \vec{i} & -\vec{j} & \vec{k} \\ x_1 & y_1 & z_1 \\ x_2 & y_2 & z_2 \end{vmatrix} = \begin{vmatrix} y_1 & z_1 \\ y_2 & z_2 \end{vmatrix} \cdot \vec{i} - \begin{vmatrix} x_1 & z_1 \\ x_2 & z_2 \end{vmatrix} \cdot \vec{j} + \begin{vmatrix} x_1 & y_1 \\ x_2 & y_2 \end{vmatrix} \cdot \vec{k}$$

$$\vec{V}_1 \wedge \vec{V}_2 = (y_1 z_2 - z_1 y_2) \cdot \vec{i} - (x_1 z_2 - z_1 x_2) \cdot \vec{j} + (x_1 y_2 - y_1 x_2) \cdot \vec{k}$$

2.3.7.2. Magnitude of the cross product طويلة الجداء الشعاعي

The magnitude of the cross product of two vectors represents the area of a parallelogram formed by these two vectors:

$$\|\vec{V}_1 \wedge \vec{V}_2\| = \|\vec{V}_1\| \cdot \|\vec{V}_2\| \cdot |\sin\theta|$$

$$h = V_2 \cdot |\sin\theta| \Rightarrow S = h \cdot V_1 = \|\vec{V}_1 \wedge \vec{V}_2\|$$

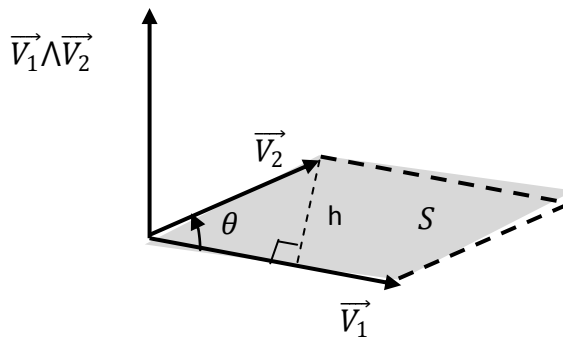

2.3.8. Mixed product الجداء المختلط

The mixed product of three vectors \vec{V}_1 , \vec{V}_2 and \vec{V}_3 is the scalar quantity defined by

$$\begin{aligned} \vec{V}_1 \cdot (\vec{V}_2 \wedge \vec{V}_3) &= \begin{vmatrix} x_1 & -y_1 & z_1 \\ x_2 & y_2 & z_2 \\ x_3 & y_3 & z_3 \end{vmatrix} \\ &= \begin{vmatrix} y_2 & z_2 \\ y_3 & z_3 \end{vmatrix} \cdot x_1 - \begin{vmatrix} x_2 & z_2 \\ x_3 & z_3 \end{vmatrix} \cdot y_1 + \begin{vmatrix} x_2 & y_2 \\ x_3 & y_3 \end{vmatrix} \cdot z_1 \end{aligned}$$

$$\vec{V}_1 \cdot (\vec{V}_2 \wedge \vec{V}_3) = (y_2 \cdot z_3 - z_2 \cdot y_3) \cdot x_1 - (x_2 \cdot z_3 - z_2 \cdot x_3) \cdot y_1 + (x_2 \cdot y_3 - y_2 \cdot x_3) \cdot z_1$$

Note :

The value obtained from the mixed product of the three vectors is equal to the volume of the parallelepiped formed by these three vectors.

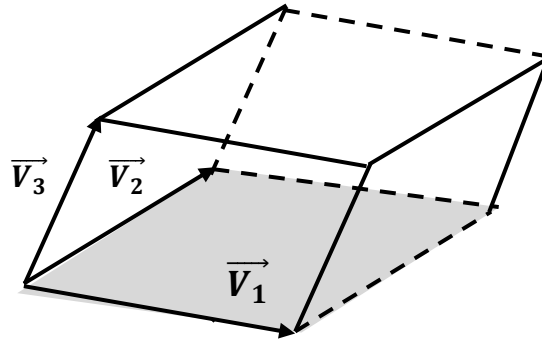

2.3.8.1. Properties:

- ❖ $\vec{V}_1 \cdot (\vec{V}_2 \wedge \vec{V}_3) = \vec{V}_3 \cdot (\vec{V}_1 \wedge \vec{V}_2) = \vec{V}_2 \cdot (\vec{V}_3 \wedge \vec{V}_1)$
- ❖ $\vec{V}_1 \cdot (\vec{V}_2 \wedge \vec{V}_3) = 0 \Rightarrow$ Either the three vectors are in the same plane or $\vec{V}_2 \parallel \vec{V}_3$.

2.3.9. Triple product: الجداء المضاعف

The triple product of three vectors \vec{V}_1, \vec{V}_2 and \vec{V}_3 is defined by the vector D or:

$$\vec{D} = \vec{V}_1 \wedge (\vec{V}_2 \wedge \vec{V}_3) = (\vec{V}_1 \cdot \vec{V}_3) \cdot \vec{V}_2 - (\vec{V}_1 \cdot \vec{V}_2) \cdot \vec{V}_3$$

2.4. Moment of a vector عزم شعاع

2.4.1. Moment of a vector relative to a point عزم شعاع بالنسبة إلى نقطة

The moment of a vector \vec{V}_1 , which passes through point A, relative to a point O is defined by the vector \vec{M} such that:

$$\vec{M}_{\vec{V}_1/O} = \vec{OA} \wedge \vec{V}_1$$

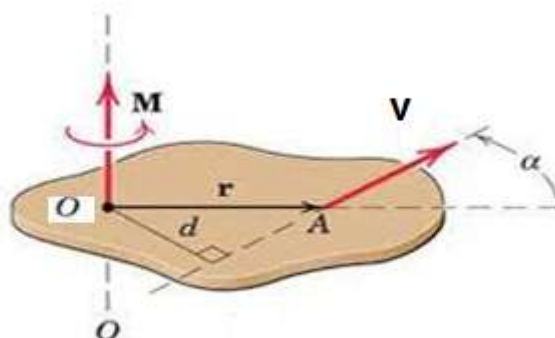

2.4.2. Moment of a vector relative to an axis عزم شعاع بالنسبة إلى محور

The moment of a vector \vec{V}_1 , which passes through point A, relative to an axis(Δ) is given by the scalar product \mathcal{M} such that:

$$\mathcal{M}_{\vec{V}_1/(\Delta)} = \vec{\mathcal{M}}_{\vec{V}_1/O} = (\overrightarrow{OA} \wedge \vec{V}_1) \cdot \vec{u}_\Delta$$

\vec{u}_Δ : the unit vector of the axis (Δ).

2.5. Vector derivatives

Let a vector \vec{V} depend on time (t) (vector function):

$$\vec{V}(t) = x(t)\vec{i} + y(t)\vec{j} + z(t)\vec{k}$$

The derivative of the vector \vec{V} with respect to time is defined as follows:

$$\frac{d\vec{V}}{dt} = \frac{dx}{dt}\vec{i} + \frac{dy}{dt}\vec{j} + \frac{dz}{dt}\vec{k}$$

Note: Velocity and acceleration are vector functions.

2.5.1. Properties

Consider two vector functions $\vec{A}(t)$ and $\vec{B}(t)$ and $f(t)$ a scalar function:

- $\frac{d}{dt}(\vec{A} + \vec{B}) = \frac{d\vec{A}}{dt} + \frac{d\vec{B}}{dt}$
- $\frac{d}{dt}(f \cdot \vec{A}) = \frac{df}{dt} + f \cdot \frac{d\vec{A}}{dt}$
- $\frac{d}{dt}(\vec{A} \cdot \vec{B}) = \frac{d\vec{A}}{dt} \cdot \vec{B} + \vec{A} \cdot \frac{d\vec{B}}{dt}$
- $\frac{d}{dt}(\vec{A} \wedge \vec{B}) = \frac{d\vec{A}}{dt} \wedge \vec{B} + \vec{A} \wedge \frac{d\vec{B}}{dt}$

2.6. Vector analysis التحليل الشعاعي

2.6.1. “Nabla” operator المؤثر نبلا

The nabla operator $\vec{\nabla}$ is a vector quantity written in cartesian coordinates:

$$\vec{\nabla} = \frac{\partial}{\partial x}\vec{i} + \frac{\partial}{\partial y}\vec{j} + \frac{\partial}{\partial z}\vec{k}$$

2.6.1.1. “Gradient” operator مؤثر التدرج

Let $f(x, y, z)$ be a scalar function. Gradient of f is given by the following vector:

$$\overrightarrow{\text{grad}} f = \vec{\nabla} f = \left(\frac{\partial f}{\partial x} \right) \vec{i} + \left(\frac{\partial f}{\partial y} \right) \vec{j} + \left(\frac{\partial f}{\partial z} \right) \vec{k}$$

2.6.1.2. “Divergence” operator مثر التباعد

Let it be $\vec{V} = V_x \vec{i} + V_y \vec{j} + V_z \vec{k}$ a vector function. We define $\text{div} \vec{V}$ as follows:

$$\text{div} \vec{V} = \vec{\nabla} \cdot \vec{V} = \frac{\partial V_x}{\partial x} + \frac{\partial V_y}{\partial y} + \frac{\partial V_z}{\partial z}$$

2.6.1.3. “Curl” operator مؤثر الدوران

Let it be $\vec{V} = V_x \vec{i} + V_y \vec{j} + V_z \vec{k}$ a vector function. We define $\overrightarrow{\text{rot}}(\vec{V})$ as follows:

$$\overrightarrow{\text{rot}}(\vec{V}) = \vec{\nabla} \wedge \vec{V} = \left(\frac{\partial V_z}{\partial y} - \frac{\partial V_y}{\partial z} \right) \vec{i} - \left(\frac{\partial V_z}{\partial x} - \frac{\partial V_x}{\partial z} \right) \vec{j} + \left(\frac{\partial V_y}{\partial x} - \frac{\partial V_x}{\partial y} \right) \vec{k}$$

2.6.1.4. “Laplacian” operator مؤثر لابلاسيان

- Laplacian of a scalar function is defined by the following relation:

$$\vec{\nabla}^2 \cdot (f) = \vec{\nabla} \cdot \vec{\nabla} (f) = \frac{\partial^2 f}{\partial x^2} + \frac{\partial^2 f}{\partial y^2} + \frac{\partial^2 f}{\partial z^2}$$

- Laplacian of a vector function is given by the following relation:

$$\vec{\nabla}^2 \cdot (\vec{V}) = \vec{\nabla} \cdot \vec{\nabla} (\vec{V}) = \frac{\partial^2 V_x}{\partial x^2} \vec{i} + \frac{\partial^2 V_y}{\partial y^2} \vec{j} + \frac{\partial^2 V_z}{\partial z^2} \vec{k}$$

Exercises

Exercise 1

Let the vectors in space be $\vec{V}_1 = 2\vec{i} - \vec{j} + 3\vec{k}$ and $\vec{V}_2 = -\vec{i} + \vec{j} + 2\vec{k}$ represented in the frame $R(O, \vec{i}, \vec{j}, \vec{k})$

-Calculate the angle between the two vectors \vec{V}_1 and \vec{V}_2 .

Exercise 2

Let the vectors in space be represented in an orthonormal coordinate system $R(OXYZ)$,

$$\vec{V}_1 = 2\vec{i} - 3\vec{j} + \vec{k} \quad \text{and} \quad \vec{V}_2 = -\vec{i} + 2\vec{j} + \vec{k}$$

1. Represent these vectors in the reference $R(OXYZ)$.
2. Calculate $\vec{R} = \vec{V}_1 + \vec{V}_2$ and the modules: $\|\vec{V}_1\|$, $\|\vec{V}_2\|$.
3. Calculate the scalar product of \vec{V}_1 and \vec{V}_2 and deduce the angle between them.
4. Determine the unit vector carried by the vector \vec{V}_2 . Deduce the direction cosines of \vec{V}_2 .

Exercise 3

Let the vectors in space be represented in an orthonormal coordinate system $R(OXYZ)$,

$$\vec{V}_2 = \vec{i} + \vec{j} + \vec{k} \quad \text{and} \quad \vec{V}_1 = 2\vec{i} + \vec{j} - \vec{k}$$

-Calculate the projection and the vector projection of the vector \vec{V}_2 onto the vector \vec{V}_1 .

Exercise 4

Consider the points $A(1,0,-1)$, $B(-1,2,1)$, $C(2,1,3)$ and $D(0,1,0)$ in the frame $(OXYZ)$.

- 1- Determine the components and magnitudes of the vectors \vec{AB} , \vec{AC} and \vec{AD} .
- 2-

- 3- Determine the projection and the vector projection of \overrightarrow{AB} on \overrightarrow{AC} .
- 4- Calculate the surface (area) of triangle ABC and the volume constituted by \overrightarrow{AB} , \overrightarrow{AC} and \overrightarrow{AD} .

Exercise 5

In the frame $R(O, \vec{i}, \vec{j}, \vec{k})$ we give the sliding vector $\vec{V} = \vec{i} + 2\vec{j} + 3\vec{k}$ and which passes through the point A(3, 4, 2).

1. Calculate the moment of the vector \vec{V} relative to the origin O , then relative to the axes OX and OY.
2. Calculate the moment of vector \vec{V} relative to point B (3, 6, 0)
3. Consider the (Δ) axis of unit vector \vec{u} $(-1/\sqrt{2}, 1/2, 1/2)$ and passing through B, calculate the moment of \vec{V} relative to (Δ) .

Solution

Exercise 1

We have $\vec{V}_1 \cdot \vec{V}_2 = \|\vec{V}_1\| \cdot \|\vec{V}_2\| \cdot \cos\theta \Rightarrow \cos\theta = \frac{\vec{V}_1 \cdot \vec{V}_2}{\|\vec{V}_1\| \cdot \|\vec{V}_2\|}$

$$\vec{V}_1 \cdot \vec{V}_2 = \begin{pmatrix} 2 \\ -1 \\ 3 \end{pmatrix} \cdot \begin{pmatrix} -1 \\ 1 \\ 2 \end{pmatrix} = 2 \cdot (-1) + (-1) \cdot 1 + 3 \cdot (2) = -2 - 1 + 6 = 3$$

$$\|\vec{V}_1\| = \sqrt{x_1^2 + y_1^2 + z_1^2} = \sqrt{2^2 + (-1)^2 + 3^2} = \sqrt{4 + 1 + 9} = \sqrt{14}$$

$$\|\vec{V}_2\| = \sqrt{x_2^2 + y_2^2 + z_2^2} = \sqrt{(-1)^2 + 1^2 + 2^2} = \sqrt{1 + 1 + 4} = \sqrt{6}$$

$$\cos\theta = \frac{\vec{V}_1 \cdot \vec{V}_2}{\|\vec{V}_1\| \cdot \|\vec{V}_2\|} = \frac{3}{\sqrt{14}\sqrt{6}} = 0.32$$

$$\Rightarrow \boxed{\theta = 71.33}$$

Exercise 2

1. Represent \vec{V}_1 and \vec{V}_2 in the reference $R(OXYZ)$.

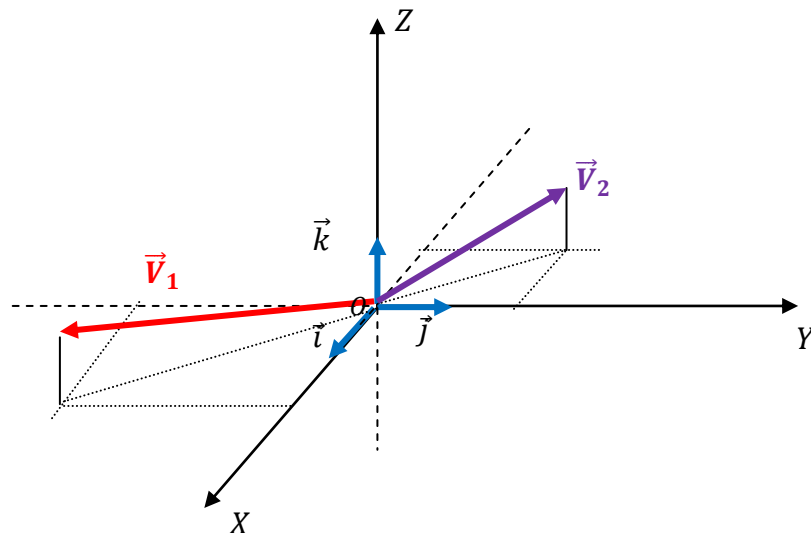

$$2. \vec{R} = \vec{V}_1 + \vec{V}_2 = \begin{pmatrix} 2 \\ -3 \\ 1 \end{pmatrix} + \begin{pmatrix} -1 \\ 2 \\ 1 \end{pmatrix} = \begin{pmatrix} 1 \\ -1 \\ 2 \end{pmatrix} = \vec{i} - \vec{j} + 2\vec{k}$$

$$\boxed{\vec{R} = \vec{i} - \vec{j} + 2\vec{k}}$$

$$\|\vec{V}_1\| = \sqrt{x_1^2 + y_1^2 + z_1^2} = \sqrt{2^2 + (-3)^2 + 1^2} = \sqrt{4 + 9 + 1} = \sqrt{14}$$

$$\boxed{\|\vec{V}_1\| = \sqrt{14}}$$

$$\|\vec{V}_2\| = \sqrt{x_2^2 + y_2^2 + z_2^2} = \sqrt{(-1)^2 + 2^2 + 1^2} = \sqrt{1 + 4 + 1} = \sqrt{6}$$

$$\boxed{\|\vec{V}_2\| = \sqrt{6}}$$

$$3. \text{ We have } \vec{V}_1 \cdot \vec{V}_2 = \begin{pmatrix} 2 \\ -3 \\ 1 \end{pmatrix} \cdot \begin{pmatrix} -1 \\ 2 \\ 1 \end{pmatrix} = 2(-1) + (-3)2 + 1(1) = -2 - 6 + 1 = -7$$

$$\boxed{\vec{V}_1 \cdot \vec{V}_2 = -7}$$

$$\vec{V}_1 \cdot \vec{V}_2 = \|\vec{V}_1\| \cdot \|\vec{V}_2\| \cdot \cos\theta \Rightarrow \cos\theta = \frac{\vec{V}_1 \cdot \vec{V}_2}{\|\vec{V}_1\| \cdot \|\vec{V}_2\|}$$

$$\cos\theta = \frac{-7}{\sqrt{14}\sqrt{6}} = -0.76$$

$$\boxed{\theta = 139.79^\circ}$$

3. unit vector carried by the vector \vec{V}_2 :

$$\vec{V}_2 = \|\vec{V}_2\| \cdot \vec{u}_2 \Rightarrow \vec{u}_2 = \frac{\vec{V}_2}{\|\vec{V}_2\|} = \frac{-1}{\sqrt{6}}\vec{i} + \frac{2}{\sqrt{6}}\vec{j} + \frac{1}{\sqrt{6}}\vec{k}$$

$$\boxed{\vec{u}_2 = \frac{-1}{\sqrt{6}}\vec{i} + \frac{2}{\sqrt{6}}\vec{j} + \frac{1}{\sqrt{6}}\vec{k}}$$

- The direction cosines of \vec{V}_2 are the components of unit vector carried by the vector

\vec{V}_2

$$\vec{u}_2 = \frac{-1}{\sqrt{6}}\vec{i} + \frac{2}{\sqrt{6}}\vec{j} + \frac{1}{\sqrt{6}}\vec{k} = \cos\alpha.\vec{i} + \cos\beta.\vec{j} + \cos\gamma.\vec{k} \Rightarrow \begin{cases} \cos\alpha = \frac{-1}{\sqrt{6}} \\ \cos\beta = \frac{2}{\sqrt{6}} \\ \cos\gamma = \frac{1}{\sqrt{6}} \end{cases}$$

Exercise 3

1) The projection of the vector \vec{V}_2 onto the vector \vec{V}_1 :

$$\text{proj}_{\vec{V}_1} \vec{V}_2 = \frac{\vec{V}_1 \cdot \vec{V}_2}{V_1}$$

$$\vec{V}_1 \cdot \vec{V}_2 = \begin{pmatrix} 1 \\ 1 \\ 1 \end{pmatrix} \cdot \begin{pmatrix} 2 \\ 1 \\ -1 \end{pmatrix} = 1 \cdot 2 + 1 \cdot 1 + 1 \cdot (-1) = 2 + 1 - 1 = 2$$

$$V_1 = \sqrt{x_1^2 + y_1^2 + z_1^2} = \sqrt{2^2 + 1^2 + 1^2} = \sqrt{6}$$

$$\text{proj}_{\vec{V}_1} \vec{V}_2 = \frac{\vec{V}_1 \cdot \vec{V}_2}{V_1} = \frac{2}{\sqrt{6}}$$

$$\boxed{\text{proj}_{\vec{V}_1} \vec{V}_2 = \frac{2}{\sqrt{6}}}$$

2) the vector projection of the vector \vec{V}_2 onto the vector \vec{V}_1 :

$$\overrightarrow{\text{proj}}_{\vec{V}_1} \vec{V}_2 = \frac{\vec{V}_1 \cdot (\vec{V}_1 \cdot \vec{V}_2)}{V_1^2}$$

$$V_1^2 = 6$$

$$\Rightarrow \overrightarrow{\text{proj}}_{\vec{V}_1} \vec{V}_2 = \frac{2}{\sqrt{6}} \cdot \frac{\begin{pmatrix} 2 \\ 1 \\ -1 \end{pmatrix}}{\sqrt{6}} = \frac{1}{3}(2\vec{i} + \vec{j} - \vec{k})$$

$$\boxed{\overrightarrow{\text{proj}}_{\vec{V}_1} \vec{V}_2 = \frac{1}{3}(2\vec{i} + \vec{j} - \vec{k})}$$

Exercise 4

1. The components and magnitudes of the vectors \overrightarrow{AB} , \overrightarrow{AC} and \overrightarrow{AD}

$$\overrightarrow{AB} \begin{pmatrix} x_B - x_A \\ y_B - y_A \\ z_B - z_A \end{pmatrix} \Rightarrow \overrightarrow{AB} \begin{pmatrix} -1-1 \\ 2-0 \\ 1-(-1) \end{pmatrix} \Rightarrow \overrightarrow{AB} \begin{pmatrix} -2 \\ 2 \\ 2 \end{pmatrix} = -2\vec{i} + 2\vec{j} + 2\vec{k}$$

$$\boxed{\overrightarrow{AB} = -2\vec{i} + 2\vec{j} + 2\vec{k}}$$

$$\|\overrightarrow{AB}\| = \sqrt{(-2)^2 + 2^2 + 2^2} = \sqrt{4 + 4 + 4} = \sqrt{12} = 2\sqrt{3}$$

$$\boxed{\|\overrightarrow{AB}\| = 2\sqrt{3}}$$

$$\overrightarrow{AC} \begin{pmatrix} x_C - x_A \\ y_C - y_A \\ z_C - z_A \end{pmatrix} \Rightarrow \overrightarrow{AC} \begin{pmatrix} 2-1 \\ 1-0 \\ 3-(-1) \end{pmatrix} \Rightarrow \overrightarrow{AC} \begin{pmatrix} 1 \\ 1 \\ 4 \end{pmatrix} = \vec{i} + \vec{j} + 4\vec{k}$$

$$\boxed{\overrightarrow{AC} = \vec{i} + \vec{j} + 4\vec{k}}$$

$$\|\overrightarrow{AC}\| = \sqrt{1^2 + 1^2 + 4^2} = \sqrt{18} = 3\sqrt{2}$$

$$\boxed{\|\overrightarrow{AC}\| = 3\sqrt{2}}$$

$$\overrightarrow{AD} \begin{pmatrix} x_D - x_A \\ y_D - y_A \\ z_D - z_A \end{pmatrix} \Rightarrow \overrightarrow{AD} \begin{pmatrix} 0-1 \\ 1-0 \\ 0-(-1) \end{pmatrix} \Rightarrow \overrightarrow{AD} \begin{pmatrix} -1 \\ 1 \\ 1 \end{pmatrix} = -\vec{i} + \vec{j} + \vec{k}$$

$$\boxed{\overrightarrow{AD} = -\vec{i} + \vec{j} + \vec{k}}$$

$$\|\overrightarrow{AD}\| = \sqrt{1^2 + 1^2 + 1^2} = \sqrt{3}$$

$$\boxed{\|\overrightarrow{AD}\| = \sqrt{3}}$$

2. The projection and the vector projection of \overrightarrow{AB} on \overrightarrow{AC} :

a) The projection of \overrightarrow{AB} on \overrightarrow{AC}

$$proj_{\overrightarrow{AB}/\overrightarrow{AC}} = \frac{\overrightarrow{AB} \cdot \overrightarrow{AC}}{\|\overrightarrow{AC}\|}$$

$$\overrightarrow{AB} \cdot \overrightarrow{AC} = \begin{pmatrix} -2 \\ 2 \\ 2 \end{pmatrix} \cdot \begin{pmatrix} 1 \\ 1 \\ 4 \end{pmatrix} = -2 + 2 + 8 = 8$$

$$proj_{\overrightarrow{AB}/\overrightarrow{AC}} = \frac{\overrightarrow{AB} \cdot \overrightarrow{AC}}{\|\overrightarrow{AC}\|} = \frac{8}{3\sqrt{2}}$$

$$proj_{\overrightarrow{AB}/\overrightarrow{AC}} = \frac{8}{3\sqrt{2}}$$

b) The vector projection of \overrightarrow{AB} on \overrightarrow{AC} :

$$\overrightarrow{proj}_{\overrightarrow{AB}/\overrightarrow{AC}} = proj_{\overrightarrow{AB}/\overrightarrow{AC}} \cdot \vec{u}_{\overrightarrow{AC}} = \frac{\overrightarrow{AC} \cdot (\overrightarrow{AB} \cdot \overrightarrow{AC})}{\|\overrightarrow{AC}\|^2}$$

$$\Rightarrow \overrightarrow{proj}_{\overrightarrow{AB}/\overrightarrow{AC}} = 8 \cdot \frac{(\vec{i} + \vec{j} + 4\vec{k})}{18} = \frac{4}{9}(\vec{i} + \vec{j} + 4\vec{k})$$

$$\overrightarrow{proj}_{\overrightarrow{AB}/\overrightarrow{AC}} = \frac{4}{9}(\vec{i} + \vec{j} + 4\vec{k})$$

3. The surface (area) S_{ABC} of triangle ABC:

$$S = \|\overrightarrow{AB} \wedge \overrightarrow{AC}\|$$

$$\overrightarrow{AB} \wedge \overrightarrow{AC} = \begin{vmatrix} \vec{i} & -\vec{j} & \vec{k} \\ -2 & 2 & 2 \\ 1 & 1 & 4 \end{vmatrix}$$

$$\overrightarrow{AB} \wedge \overrightarrow{AC} = (8 - 2)\vec{i} - (-8 - 2)\vec{j} + (-2 - 2)\vec{k}$$

$$\overrightarrow{AB} \wedge \overrightarrow{AC} = 6.\vec{i} + 10.\vec{j} - 4.\vec{k}$$

$$\|\overrightarrow{AB} \wedge \overrightarrow{AC}\| = \sqrt{6^2 + 10^2 + (-4)^2} = \sqrt{152}$$

$$S_{ABC} = \frac{S}{2} = \frac{\sqrt{152}}{2} \quad (su)$$

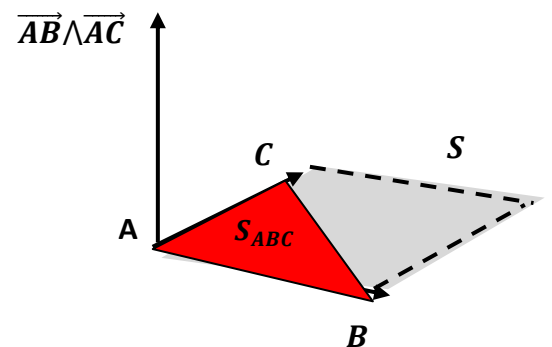

- the volume constituted by \overrightarrow{AB} , \overrightarrow{AC} and \overrightarrow{AD} :

$$\overrightarrow{AD}(\overrightarrow{AB} \wedge \overrightarrow{AC}) = \begin{vmatrix} -1 & -1 & 1 \\ -2 & 2 & 2 \\ 1 & 1 & 4 \end{vmatrix} = 0$$

V=0, either the 3 vectors are in the same plane

Exercise 5

$\vec{V} = \vec{i} + 2\vec{j} + 3\vec{k}$ which passes through the point A(3, 4, 2).

1. The moment of the vector \vec{V} relative to the origin O

$$\vec{\mathcal{M}}_{\vec{V}/O} = \overrightarrow{OA} \wedge \vec{V}$$

$$\overrightarrow{OA} \begin{pmatrix} x_A - x_O \\ y_A - y_O \\ z_A - z_O \end{pmatrix} \Rightarrow \overrightarrow{OA} \begin{pmatrix} 3 - 0 \\ 4 - 0 \\ 2 - 0 \end{pmatrix} \Rightarrow \overrightarrow{OA} \begin{pmatrix} 3 \\ 4 \\ 2 \end{pmatrix}$$

$$\vec{\mathcal{M}}_{\vec{V}/O} = \overrightarrow{OA} \wedge \vec{V} = \begin{vmatrix} \vec{i} & -\vec{j} & \vec{k} \\ 3 & 4 & 2 \\ 1 & 2 & 3 \end{vmatrix}$$

$$\vec{\mathcal{M}}_{\vec{V}/O} = (4.3 - 2.2).\vec{i} - (3.3 - 2.1).\vec{j} + (3.2 - 4.1).\vec{k}$$

$$\boxed{\vec{\mathcal{M}}_{\vec{V}/O} = 8.\vec{i} - 7\vec{j} + 2.\vec{k}}$$

- * Moment of \vec{V} relative to OX:

$$\vec{\mathcal{M}}_{\vec{V}/(OX)} = \vec{\mathcal{M}}_{\vec{V}/O} \cdot \vec{i} = \begin{pmatrix} 8 \\ 7 \\ 2 \end{pmatrix} \cdot \begin{pmatrix} 1 \\ 0 \\ 0 \end{pmatrix} = 8$$

- * Moment of \vec{V} relative to OY:

$$\vec{\mathcal{M}}_{\vec{V}/(OY)} = \vec{\mathcal{M}}_{\vec{V}/O} \cdot \vec{j} = \begin{pmatrix} 8 \\ 7 \\ 2 \end{pmatrix} \cdot \begin{pmatrix} 0 \\ 1 \\ 0 \end{pmatrix} = 0$$

- 2) Moment of vector \vec{V} relative to point B (3, 6, 0)

$$\vec{\mathcal{M}}_{\vec{v}/B} = \overrightarrow{BA} \wedge \vec{V}$$

$$\overrightarrow{BA} \begin{pmatrix} x_A - x_B \\ y_A - y_B \\ z_A - z_B \end{pmatrix} \Rightarrow \overrightarrow{BA} \begin{pmatrix} 3 - 3 \\ 4 - 6 \\ 2 - 0 \end{pmatrix} \Rightarrow \overrightarrow{BA} \begin{pmatrix} 0 \\ -2 \\ 2 \end{pmatrix}$$

$$\vec{\mathcal{M}}_{\vec{v}/B} = \overrightarrow{BA} \wedge \vec{V} = \begin{vmatrix} \vec{i} & -\vec{j} & \vec{k} \\ 0 & -2 & 2 \\ 1 & 2 & 3 \end{vmatrix} = (-10) \cdot \vec{i} + 2 \cdot \vec{j} + 2 \cdot \vec{k}$$

$$\boxed{\vec{\mathcal{M}}_{\vec{v}/B} = -10 \cdot \vec{i} + 2 \cdot \vec{j} + 2 \cdot \vec{k}}$$

3) Moment of \vec{V} relative to (Δ) :

$$\vec{\mathcal{M}}_{\vec{v}/(\Delta)} = \vec{\mathcal{M}}_{\vec{v}/B} \cdot \vec{u} = \begin{pmatrix} -10 \\ 2 \\ 2 \end{pmatrix} \cdot \begin{pmatrix} -1/\sqrt{2} \\ 1/2 \\ 1/2 \end{pmatrix} = \frac{10}{\sqrt{2}} + 1 + 1$$

$$\boxed{\vec{\mathcal{M}}_{\vec{v}/(\Delta)} = \frac{10}{\sqrt{2}} + 2}$$

Chapter 1

Kinematics of a particle

I.1. Introduction مقدمة

The kinematics is the mechanical branch (which is a physical branch) that determines the motion of the body in its position, velocity, acceleration, trajectory, without addressing the reasons responsible for this movement (forces). We will limit our study of kinematics to the study of the movement of a particle.

I.2. Definitions

I.2.1. Particle

The particle is an object without dimensions and its mass is concentrated in its center of gravity. Therefore any effect of rotation of the body around itself or its spatial extension will be neglected. For example, Earth can be considered a particle in relation to the solar system

I.2.2. Trajectory

The trajectory of a mobile is the set of successive positions that it occupies over time in relation to the chosen reference system. Mathematically it is a relationship linking the coordinates x , y and z to each other independently of time.

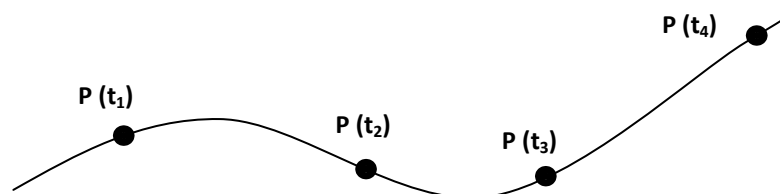

I.2.3. Equation of motion (

The equation of motion is the variation of the position of a mobile as a function of time, in a chosen reference frame.

$$\text{Example : } \begin{cases} x = 2t - 1 \\ y = t^2 \end{cases}$$

I.3. Movement characteristics

Describing the body's motion requires three vectors::

- Position vector.
- Velocity vector.
- Accélération vector.

I.3.1. Position vecteur

We call the position vector of a particle M at time t in the Cartesian coordinate system $(O, \vec{i}, \vec{j}, \vec{k})$, the vector $\vec{r}(t) = \overrightarrow{OM}$

$$\vec{r}(t) = \overrightarrow{OM} = x(t)\vec{i} + y(t)\vec{j} + z(t)\vec{k}$$

Remark:

The displacement vector represents the oriented distance which separates the starting point M from the arrival point M'

(\overrightarrow{OM} and \overrightarrow{OM}' : position vectors, \overrightarrow{MM}' displacement vector).

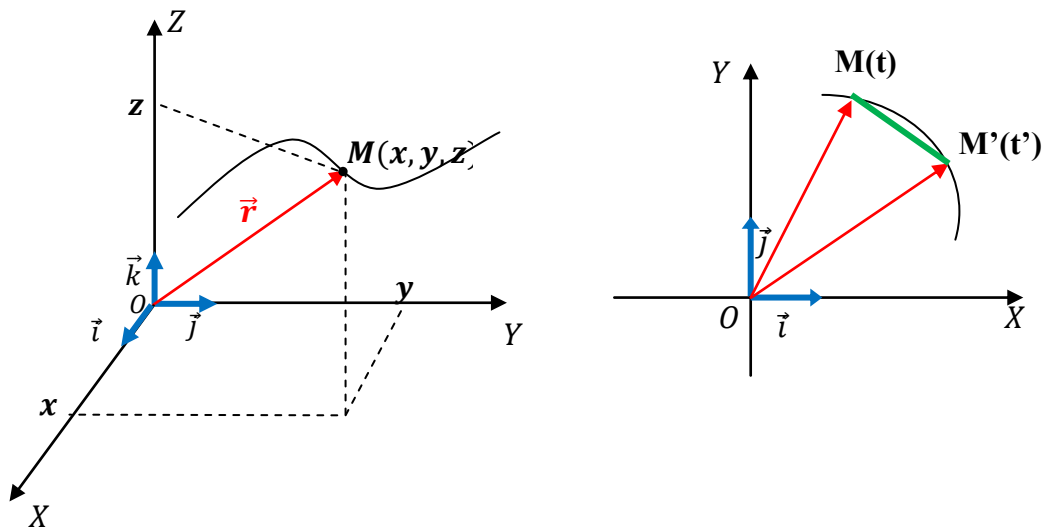

I.3.2. Velocity vector

The speed at time t is the variation of the position with respect to time. In addition, this quantity is vector.

$$\vec{v}(t) = \frac{d\overrightarrow{OM}}{dt}$$

Velocity vector \vec{v} tangent to the trajectory at point M

The unit of speed in the international system is m/s.

There are two velocity vectors: average velocity vector and instantaneous velocity vector.

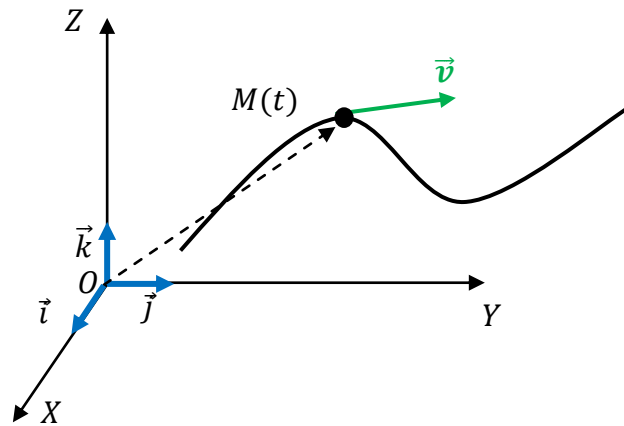

I.3.2.1. Average velocity vector

Average velocity is the change in overall distance relative to elapsed time.

Let point M be at time t and point M' at time t'

$$\vec{v}_m = \frac{\overrightarrow{MM'}}{\Delta t}$$

$$\Delta t = t' - t$$

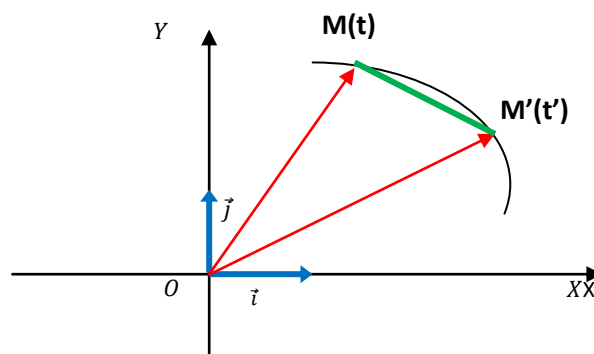

I.3.2.2. Instantaneous velocity vector

We define the instantaneous velocity at time t by:

$$\vec{v} = \lim_{\Delta t \rightarrow 0} \vec{v}_m = \frac{d\overrightarrow{OM}}{dt}$$

Remark:

The instantaneous velocity vector is carried by the tangent to the trajectory at point M

I.3.3. Accélération vector

The acceleration vector at time t is the change in velocity vector with respect to time.

$$\vec{a} = \frac{d\vec{v}}{dt} = \frac{d^2\overrightarrow{OM}}{dt^2}$$

The unit of acceleration in the system international is m/s^1 .

We distinguish two accelerations:

I.3.3.1. Average acceleration vector

Average acceleration vector is the variation in velocity vector over time

$$\vec{a}_m = \frac{\Delta\vec{v}}{\Delta t} = \frac{\vec{v}' - \vec{v}}{t' - t}$$

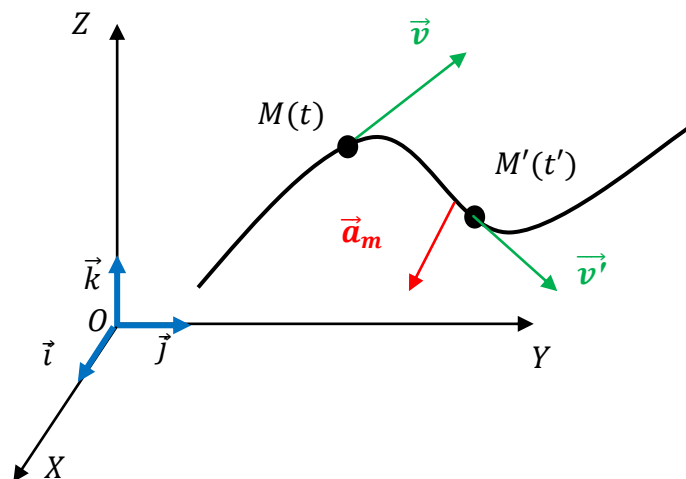

I.3.3.2. Instantaneous acceleration vector

Instantaneous acceleration is the derivative of the velocity vector with respect to time

$$\vec{a} = \lim_{\Delta t \rightarrow 0} \overrightarrow{a_m} = \lim_{\Delta t \rightarrow 0} \Delta\vec{v} =$$

$$\vec{a} = \frac{d\vec{v}}{dt} = \frac{d^2\overrightarrow{OM}}{dt^2}$$

I.4. Coordinate system

The vectors: position, velocity and acceleration of a mobile M are defined in relation to a reference frame, so the description of the movement of M requires the definition of these vectors.

I.4.1. Cartesian coordinates

Soit A direct orthonorm repair from the origin of the base $(\vec{i}, \vec{j}, \vec{k})$.

Let $R(O, \vec{i}, \vec{j}, \vec{k})$ be a direct orthonormal frame of origin O and base $(\vec{i}, \vec{j}, \vec{k})$

I.4.1.1. Position vector:

$$\overrightarrow{OM} = x\vec{i} + y\vec{j} + z\vec{k}$$

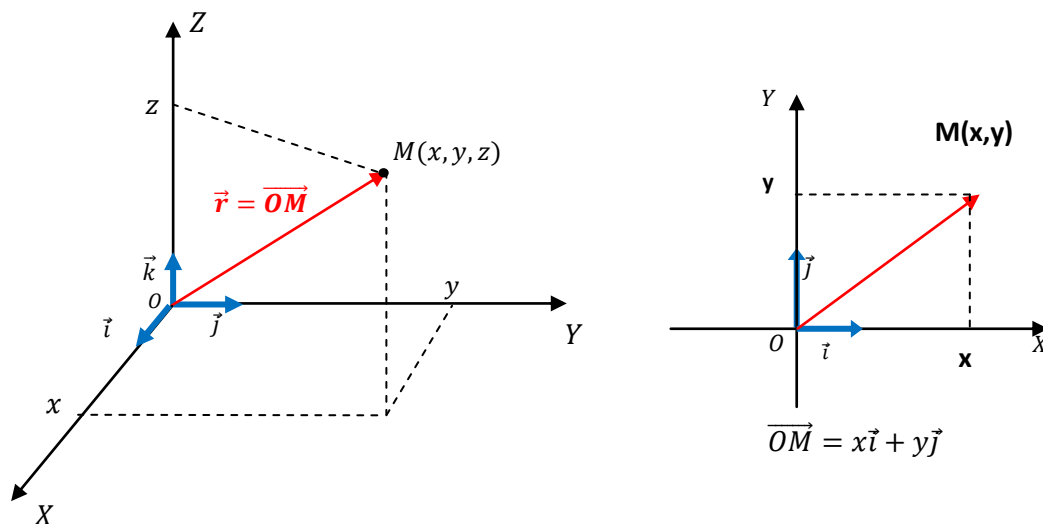

I.4.1.2. Velocity vector:

$$\vec{v} = \frac{d\overrightarrow{OM}}{dt} = \frac{dx}{dt}\vec{i} + \frac{dy}{dt}\vec{j} + \frac{dz}{dt}\vec{k} = \dot{x}\vec{i} + \dot{y}\vec{j} + \dot{z}\vec{k} = v_x\vec{i} + v_y\vec{j} + v_z\vec{k}$$

The components in cartesian coordinates of the velocity vector are therefore:

$$\begin{cases} v_x = \frac{dx}{dt} = \dot{x} \\ v_y = \frac{dy}{dt} = \dot{y} \\ v_z = \frac{dz}{dt} = \dot{z} \end{cases}$$

The unit vectors $(\vec{i}, \vec{j}, \vec{k})$ are fixed in the cartesian reference frame, therefore:

$$\frac{d\vec{i}}{dt} = \frac{d\vec{j}}{dt} = \frac{d\vec{k}}{dt} = 0$$

I.4.1.3. Accélération vector:

$$\vec{a} = \frac{d\vec{v}}{dt} = \frac{dv_x}{dt}\vec{i} + \frac{dv_y}{dt}\vec{j} + \frac{dv_z}{dt}\vec{k} = \ddot{x}\vec{i} + \ddot{y}\vec{j} + \ddot{z}\vec{k} = a_x\vec{i} + a_y\vec{j} + a_z\vec{k}$$

The components in cartesian coordinates of the velocity vector are therefore:

$$a_x = \frac{dv_x}{dt} = \ddot{x}$$

$$a_y = \frac{dv_y}{dt} = \ddot{y}$$

$$a_z = \frac{dv_z}{dt} = \ddot{z}$$

I.4.2. Polar coordinates

We can locate the position of the point M by a coordinate r (distance between the origin of the mark and the point M) and θ oriented angle that the vector \vec{r} makes with the abscissa axis (OX).

The data (r, θ) called polar coordinates. The basis of the polar coordinate system is formed by two unit vectors ($\vec{u}_r, \vec{u}_\theta$)

$$\vec{OM} = r \cdot \vec{u}_r \Rightarrow \|\vec{OM}\| = r$$

$$\|\vec{u}_r\| = \|\vec{u}_\theta\| = 1 \text{ and } \vec{u}_r \perp \vec{u}_\theta$$

$$0 \leq r < +\infty \text{ et } 0 \leq \theta \leq 2\pi$$

Polar coordinates are linked to Cartesian coordinates by:

$$\begin{cases} x = r \cdot \cos\theta \\ y = r \cdot \sin\theta \end{cases} \Rightarrow r = \sqrt{x^2 + y^2}$$

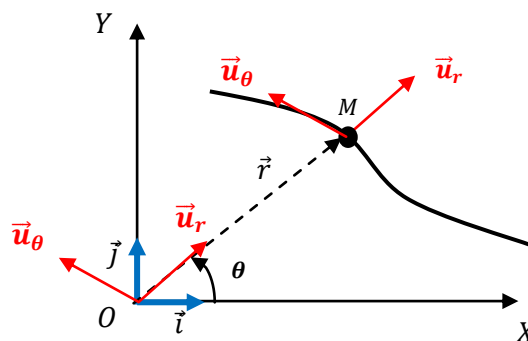

I.4.2.1. Position vector:

$$\overrightarrow{OM}(t) = \vec{r}(t) = \|\overrightarrow{OM}\| \cdot \vec{u}_r = r \cdot \vec{u}_r$$

$$\vec{u}_r = \cos\theta \cdot \vec{i} + \sin\theta \cdot \vec{j}$$

$$\overrightarrow{OM}(t) = \vec{r}(t) = r \cdot (\cos\theta \cdot \vec{i} + \sin\theta \cdot \vec{j})$$

I.4.2.2. velocity vector:

$$\vec{v}(t) = \frac{d\vec{r}(t)}{dt} = \frac{d}{dt}(r \cdot \vec{u}_r) = \frac{dr}{dt} \vec{u}_r + r \frac{d\vec{u}_r}{dt}$$

$$\frac{d\vec{u}_r}{dt} = \frac{d}{d} \cdot (\cos\theta \cdot \vec{i} + \sin\theta \cdot \vec{j}) = (-\sin\theta \cdot \vec{i} + \cos\theta \cdot \vec{j}) \frac{d\theta}{dt} = \frac{d\theta}{dt} \vec{u}_\theta$$

$$\vec{u}_\theta = -\sin\theta \cdot \vec{i} + \cos\theta \cdot \vec{j}$$

$$\vec{v}(t) = \frac{dr}{dt} \vec{u}_r + r \frac{d\theta}{dt} \vec{u}_\theta = \dot{r} \vec{u}_r + r\dot{\theta} \vec{u}_\theta$$

$$\dot{\theta}(t) = \omega(t) = \text{angular velocity} \quad \text{السرعة الزاوية}$$

$$\text{So the components of the velocity in the polar base are: } \begin{cases} v_r = \dot{r} \\ v_\theta = r\dot{\theta} \end{cases}$$

I.4.2.3. Acceleration vector:

$$\vec{a}(t) = \frac{d\vec{v}(t)}{dt} = \frac{d}{dt}(\dot{r} \vec{u}_r + r\dot{\theta} \vec{u}_\theta)$$

$$= \frac{d^2r}{dt^2} \vec{u}_r + \dot{r} \frac{d\vec{u}_r}{dt} + \frac{dr}{dt} \dot{\theta} \vec{u}_\theta + r \frac{d^2\theta}{dt^2} \vec{u}_\theta + r \dot{\theta} \frac{d\vec{u}_\theta}{dt}$$

$$\frac{d\vec{u}_\theta}{dt} = \frac{d}{d} \cdot (-\sin\theta \cdot \vec{i} + \cos\theta \cdot \vec{j}) = (-\cos\theta \cdot \vec{i} - \sin\theta \cdot \vec{j}) \frac{d\theta}{dt} = -\frac{d\theta}{dt} \vec{u}_r$$

$$\vec{a}(t) = \frac{d\vec{v}(t)}{dt} = \left(\frac{d^2r}{dt^2} - r\dot{\theta}^2 \right) \vec{u}_r + \left(2 \frac{dr}{dt} \frac{d\theta}{dt} + r \frac{d^2\theta}{dt^2} \right) \vec{u}_\theta$$

$$\vec{a}(t) = \frac{d\vec{v}(t)}{dt} = (\ddot{r} - r\dot{\theta}^2) \vec{u}_r + (2\dot{r}\dot{\theta} + r\ddot{\theta}) \vec{u}_\theta$$

$$\text{So the components of the acceleration in the polar base are: } \begin{cases} a_r = \ddot{r} - r\dot{\theta}^2 \\ a_\theta = 2\dot{r}\dot{\theta} + r\ddot{\theta} \end{cases}$$

I.4.3. Cylindrical coordinates

In the cylindrical coordinate system, a point M in space is represented by coordinates (r, θ, z) , where: r and θ are the polar coordinates of the projection of M onto the XY plane, z is the distance along the OZ axis, and the unit vectors $(\vec{u}_r, \vec{u}_\theta, \vec{k})$ constituting the basis of the cylindrical reference frame

($0 \leq r < +\infty$, $0 \leq \theta \leq 2\pi$ and $-\infty < z < +\infty$).

The movement of a point M is divided into two movements:

- a movement in the polar reference frame on the plane (XOY)
- a translation movement along the OZ axis.

I.4.3.1. Position Vector:

$$\vec{OM} = \vec{OM'} + \vec{M'M} = r \cdot \vec{u}_r + z \vec{k}$$

$$\vec{OM'} = r \cdot \vec{u}_r$$

$$\vec{M'M} = z \vec{k}$$

$$\vec{OM} = r \cdot \vec{u}_r + z \vec{k}$$

$$\|\vec{OM}\| = \sqrt{r^2 + z^2}$$

$$\vec{u}_r = \cos\theta \cdot \vec{i} + \sin\theta \cdot \vec{j}$$

$$\vec{u}_\theta = -\sin\theta \cdot \vec{i} + \cos\theta \cdot \vec{j}$$

$$\begin{cases} x = r \cdot \cos\theta \\ y = r \cdot \sin\theta \\ z = z \end{cases}$$

$$\begin{cases} r = \sqrt{x^2 + y^2} \\ \tan\theta = \frac{y}{x} \\ z = z \end{cases}$$

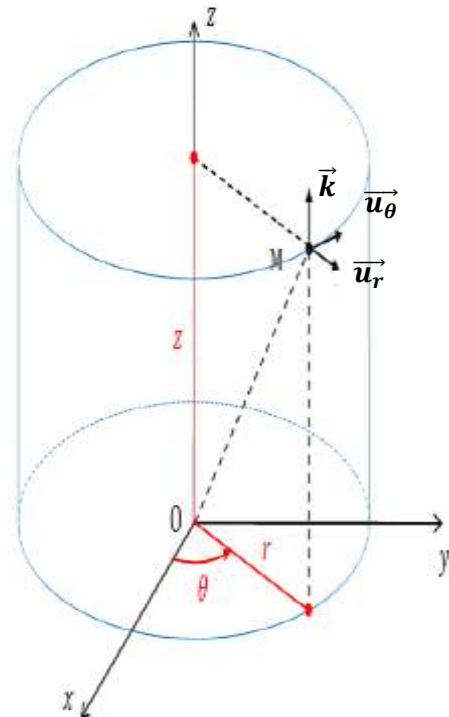

I.4.3.2. Velocity vector

$$\vec{v}(t) = \frac{d\vec{OM}}{dt} = \frac{d}{dt} (r \cdot \vec{u}_r + z \vec{k}) = \frac{dr}{dt} \vec{u}_r + r \frac{d\vec{u}_r}{dt} + \frac{dz}{dt} \vec{k} = \dot{r} \vec{u}_r + r \dot{\theta} \vec{u}_\theta + \dot{z} \vec{k}$$

So the components of the velocity vector in the cylindrical base are: $\begin{cases} v_r = \dot{r} \\ v_\theta = r \dot{\theta} \\ v_z = \dot{z} \end{cases}$

I.4.3.3. Acceleration vector

$$\begin{aligned}\vec{a} &= \frac{d\vec{v}}{dt} = \frac{d}{dt} (\dot{r} \vec{u}_r + r\dot{\theta} \vec{u}_\theta + \dot{z} \vec{k}) \\ &= \frac{d^2r}{dt^2} \vec{u}_r + \dot{r} \frac{d\vec{u}_r}{dt} + \frac{dr}{dt} \dot{\theta} \vec{u}_\theta + r \frac{d^2\theta}{dt^2} \vec{u}_\theta + r \dot{\theta} \frac{d\vec{u}_\theta}{dt} + \ddot{z} \vec{k} \\ \vec{a} &= \frac{d\vec{v}}{dt} = \left(\frac{d^2r}{dt^2} - r\dot{\theta}^2 \right) \vec{u}_r + \left(2 \frac{dr}{dt} \frac{d\theta}{dt} + r \frac{d^2\theta}{dt^2} \right) \vec{u}_\theta + \ddot{z} \vec{k}\end{aligned}$$

$$\vec{a}(t) = \frac{d\vec{v}(t)}{dt} = (\ddot{r} - r\dot{\theta}^2) \vec{u}_r + (2\dot{r}\dot{\theta} + r\ddot{\theta}) \vec{u}_\theta + \ddot{z} \vec{k}$$

So the components of the acceleration vector in the cylindrical base are:

$$\begin{cases} a_r = \ddot{r} - r\dot{\theta}^2 \\ a_\theta = 2\dot{r}\dot{\theta} + r\ddot{\theta} \\ a_z = \ddot{z} \end{cases}$$

I.4.4. Spherical coordinates

A point M is represented in the spherical coordinate system, by the coordinates (r, θ, φ) , where the unitary vectors $(\vec{u}_r, \vec{u}_\theta, \vec{u}_\varphi)$ constituting the basis:

$$0 \leq r < +\infty$$

$$0 \leq \theta \leq \pi$$

$$0 \leq \varphi < 2\pi).$$

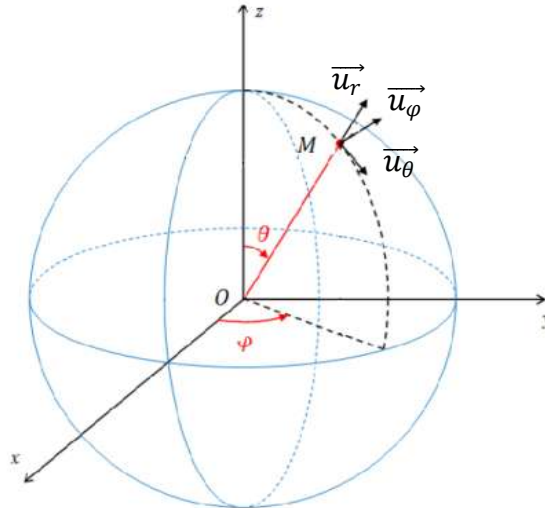

I.4.4.1. Position Vector

$$\vec{OM} = r \cdot \vec{u}_r$$

$$\begin{cases} \vec{u}_r = \sin \theta \cos \varphi \cdot \vec{i} + \sin \theta \sin \varphi \cdot \vec{j} + \cos \theta \vec{k} \\ \vec{u}_\theta = \frac{d\vec{u}_r}{d\theta} = \cos \varphi \cos \theta \cdot \vec{i} + \sin \varphi \cos \theta \cdot \vec{j} - \sin \theta \vec{k} \\ \vec{u}_\varphi = \vec{u}_r \wedge \vec{u}_\theta = -\sin \varphi \cdot \vec{i} + \cos \varphi \cdot \vec{j} \end{cases}$$

$$\overrightarrow{OM} = r\overrightarrow{u}_r = r(\sin\theta \cos\varphi\vec{i} + \sin\theta \sin\varphi\vec{j} + \cos\theta\vec{k})$$

$$\overrightarrow{OM} = \begin{cases} x = r\sin\theta \cos\varphi \\ y = r\sin\theta \sin\varphi \\ z = r\cos\theta \end{cases}$$

I.4.4.2. Velocity vector

$$\vec{v}(t) = \frac{d\overrightarrow{OM}}{dt} = \frac{d}{dt}(r \cdot \overrightarrow{u}_r) = \frac{dr}{dt}\overrightarrow{u}_r + r \frac{d\overrightarrow{u}_r}{dt}$$

$$\begin{aligned} \frac{d\overrightarrow{u}_r}{dt} &= \frac{d\overrightarrow{u}_r}{d\theta} \frac{d\theta}{dt} + \frac{d\overrightarrow{u}_r}{d\varphi} \frac{d\varphi}{dt} \\ &= \dot{\theta}(\cos\theta\cos\varphi\vec{i} + \cos\theta\sin\varphi\vec{j} - \sin\theta\vec{k}) \\ &\quad + \dot{\varphi}(-\sin\theta\sin\varphi\vec{i} + \sin\theta\cos\varphi\vec{j}) \end{aligned}$$

$$\frac{d\overrightarrow{u}_r}{dt} = \dot{\theta}\overrightarrow{u}_\theta + \dot{\varphi} \sin\theta \overrightarrow{u}_\varphi$$

$$\vec{v} = \dot{r}\overrightarrow{u}_r + r\dot{\theta}\overrightarrow{u}_\theta + r\dot{\varphi} \sin\theta \overrightarrow{u}_\varphi$$

The components of velocity vector in the spherical basis are: $\vec{v} = \begin{cases} v_r = \dot{r} \\ v_\theta = r\dot{\theta} \\ v_z = r\dot{\varphi} \sin\theta \end{cases}$

I.4.4.3. Acceleration vector

$$\vec{a} = \frac{d\vec{v}}{dt} = \frac{d}{dt}(\dot{r}\overrightarrow{u}_r + r\dot{\theta}\overrightarrow{u}_\theta + r\dot{\varphi} \sin\theta \overrightarrow{u}_\varphi)$$

$$\begin{aligned} \vec{a} &= \frac{d\dot{r}}{dt}\overrightarrow{u}_r + \dot{r} \frac{d\overrightarrow{u}_r}{dt} + \frac{dr}{dt}\dot{\theta}\overrightarrow{u}_\theta + r \frac{d\dot{\theta}}{dt}\overrightarrow{u}_\theta + r\dot{\theta} \frac{d\overrightarrow{u}_\theta}{dt} + \frac{dr}{dt}\dot{\varphi} \sin\theta \overrightarrow{u}_\varphi + r \frac{d\dot{\varphi}}{dt} \sin\theta \overrightarrow{u}_\varphi \\ &\quad + r\dot{\varphi} \frac{d \sin\theta}{dt} \overrightarrow{u}_\varphi + r\dot{\varphi} \sin\theta \frac{d\overrightarrow{u}_\varphi}{dt} \end{aligned}$$

$$\frac{d\overrightarrow{u}_\theta}{dt} = \frac{d\overrightarrow{u}_\theta}{d\theta} \frac{d\theta}{dt} + \frac{d\overrightarrow{u}_\theta}{d\varphi} \frac{d\varphi}{dt}$$

$$\frac{d\overrightarrow{u}_\theta}{dt} = \dot{\theta}(-\sin\theta\cos\varphi\vec{i} - \sin\theta\sin\varphi\vec{j} - \cos\theta\vec{k}) + \dot{\varphi}(-\cos\theta\sin\varphi\vec{i} + \cos\theta\cos\varphi\vec{j})$$

$$\frac{d\overrightarrow{u}_\theta}{dt} = -\dot{\theta}\overrightarrow{u}_r + \dot{\varphi} \cos\theta \overrightarrow{u}_\varphi$$

$$\begin{aligned}\vec{u}_\varphi &= \vec{u}_r \wedge \vec{u}_\theta = \frac{d\vec{u}_r}{dt} \wedge \vec{u}_\theta + \vec{u}_r \wedge \frac{d\vec{u}_\theta}{dt} \\ &= (\dot{\theta}\vec{u}_\theta + \dot{\varphi} \sin \theta \vec{u}_\varphi) \wedge \vec{u}_\theta + \vec{u}_r \wedge (-\dot{\theta}\vec{u}_r + \dot{\varphi} \cos \theta \vec{u}_\varphi)\end{aligned}$$

$$\vec{u}_\varphi = -\dot{\varphi}(\sin \theta \vec{u}_r + \cos \theta \vec{u}_\theta)$$

$$\begin{aligned}\vec{a} &= (\ddot{r} - r\dot{\theta}^2 - r\dot{\varphi}^2 \sin^2 \theta)\vec{u}_r + (2\dot{r}\dot{\theta} + r\ddot{\theta} - r\dot{\varphi}^2 \sin \theta \cos \theta)\vec{u}_\theta \\ &\quad + (2\dot{r}\dot{\varphi} \sin \theta + 2r\dot{\theta}\dot{\varphi} \cos \theta + r\ddot{\varphi} \sin \theta)\vec{u}_\varphi\end{aligned}$$

The acceleration components in the sphérique basis are:

$$\vec{a} = \begin{cases} a_r = \ddot{r} - r\dot{\theta}^2 - r\dot{\varphi}^2 \sin^2 \theta \\ a_\theta = 2\dot{r}\dot{\theta} + r\ddot{\theta} - r\dot{\varphi}^2 \sin \theta \cos \theta \\ a_\varphi = 2\dot{r}\dot{\varphi} \sin \theta + 2r\dot{\theta}\dot{\varphi} \cos \theta + r\ddot{\varphi} \sin \theta \end{cases}$$

1.4.5. Frenet frame (Intrinsic basis)

For movements on curvilinear trajectories, the study of point M in cartesian coordinates is complex. Frenet frame, associated with point M, makes it possible to overcome this difficulty. We associate two unit vectors: \vec{u}_t and \vec{u}_n .

Frenet frame is a reference frame that moves with the mobile M. Its characteristics are:

- Its origin is a point M
- Unit vector \vec{u}_t is tangent to the trajectory in M and oriented in the direction of movement.
- Unit vector \vec{u}_n is normal to the trajectory in M (and therefore also to \vec{u}_t) and oriented towards the center of the curvature

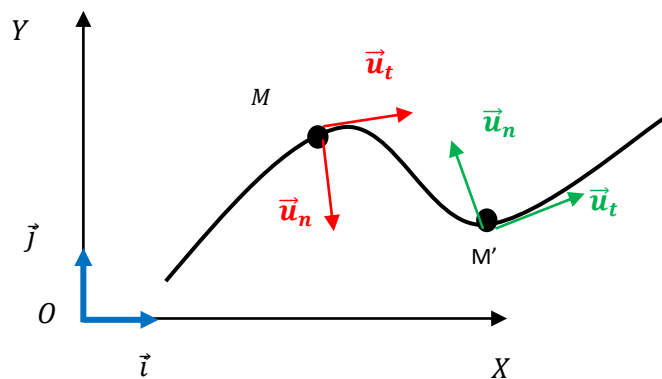

I.4.5.1. Curvilinear abscissa

The curvilinear abscissa s at time t of point M is the algebraic value of the arc (MM')

$$s(t) = \widehat{MM'} \quad (MM' = OM' - OM = r' - r = \Delta r)$$

When M' approaches M , $M'M = dr = dOM$

$$\text{So } d\overrightarrow{OM} = ds \overrightarrow{u}_t$$

I.4.5.2. Velocity vector in the Frenet reference frame:

By definition, the velocity vector is the derivative of the position vector

$$\vec{v} = \frac{d\overrightarrow{OM}}{dt} = \frac{d\overrightarrow{OM}}{ds} \frac{ds}{dt} \Rightarrow \frac{ds}{dt} \overrightarrow{u}_t = v \overrightarrow{u}_t = \begin{pmatrix} v \\ 0 \end{pmatrix}$$

$$\vec{v} = v \overrightarrow{u}_t$$

Where the speed v (magnitude) in this system is expressed by the derivative of the curvilinear abscissa s with respect to time:

$$v = \frac{ds}{dt}$$

The velocity vector is always tangential to the trajectory of the mobile.

I.4.5.3. Acceleration vector in the Frenet reference frame:

The acceleration vector is defined by the derivative of the velocity vector:

$$\vec{a} = \frac{d\vec{v}}{dt} = \frac{d}{dt}(v \overrightarrow{u}_t) = \frac{dv}{dt} \overrightarrow{u}_t + v \frac{d\overrightarrow{u}_t}{dt}$$

$$\frac{d\overrightarrow{u}_t}{dt} = \frac{d\overrightarrow{u}_t}{ds} \frac{ds}{dt} = \frac{d\overrightarrow{u}_t}{ds} \frac{ds}{d\theta} \frac{d\theta}{dt} = \frac{d\overrightarrow{u}_t}{d\theta} \frac{ds}{dt} \frac{d\theta}{ds}$$

The derivative of the unit vector \overrightarrow{u}_t with respect to θ gives:

$$\frac{d\overrightarrow{u}_t}{d\theta} = \overrightarrow{u}_n$$

$$\text{The sd arc : } ds = R d\theta \Rightarrow \frac{d\theta}{ds} = \frac{1}{R}$$

Where R represents the radius of the curvature of the trajectory.

$$\frac{d\overrightarrow{u}_t}{dt} = \frac{v}{R} \overrightarrow{u}_n$$

$$\vec{a} = \frac{dv}{dt} \vec{u}_t + \frac{v^2}{R} \vec{u}_n$$

$$\text{Tangential acceleration} \quad \vec{a}_t = \frac{dv}{dt} \vec{u}_t$$

$$\text{Normal acceleration} \quad \vec{a}_n = \frac{v^2}{R} \vec{u}_n$$

$$\vec{a} = a_t \vec{u}_t + a_n \vec{u}_n$$

$$\|\vec{a}\| = \sqrt{a_t^2 + a_n^2}$$

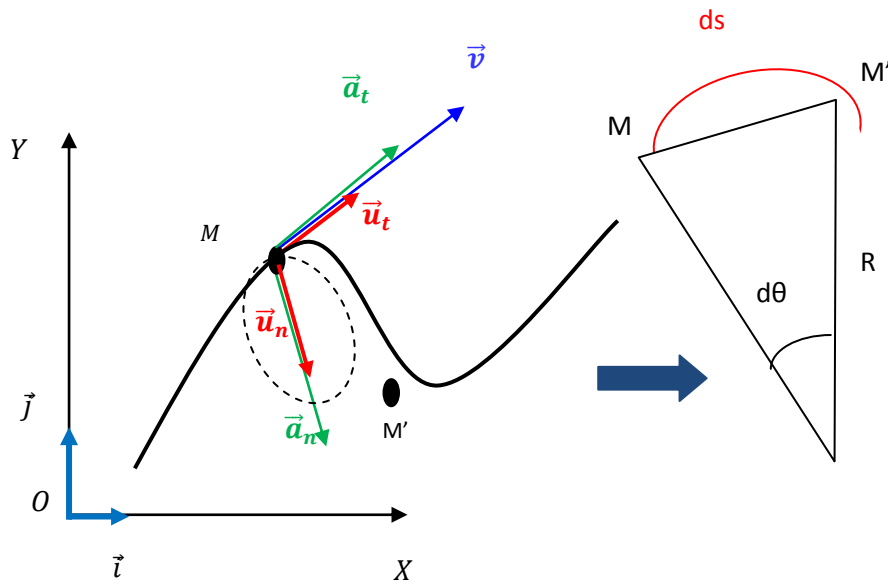

1.5. Types of movement أنواع الحركة

If we consider the path as the criterion for dividing movement, we have two types of movement:

1.5.1. Rectilinear Movement الحركة المستقيمة

The body's movement is rectified if the track is a drop. The repère is composed of an ax (Ox). The point M is repeated by my son x.

$$\vec{r}(t) = \overline{OM} = x(t) \vec{i}$$

$$\vec{v} = \frac{d\overline{OM}}{dt} = \frac{dx}{dt} \vec{i} = \dot{x} \vec{i}$$

$$\vec{a} = \frac{d\vec{v}}{dt} = \frac{d^2\overline{OM}}{dt^2} = \frac{d^2x}{dt^2} \vec{i} = \ddot{x} \vec{i}$$

I.5.1.1. Uniform rectilinear movement الحركة المستقيمة المنتظمة

The motion rectangle uniform and the vitesse are constant at all times.

$$v(t) = v_0 = cte$$

$$a = \frac{dv}{dt} = 0$$

$$v = \frac{dx}{dt} = v_0 \Rightarrow dx = v_0 dt \Rightarrow \int_{x_0}^x dx = \int_{t_0}^t v_0 dt \Rightarrow x - x_0 = v_0(t - t_0)$$

$$\Rightarrow x = x_0 + v_0(t - t_0)$$

$$\text{If at } t_0 = 0 \text{ and } x_0 = 0 \Rightarrow \begin{cases} x = v_0 t \\ v(t) = v_0 \\ a(t) = 0 \end{cases}$$

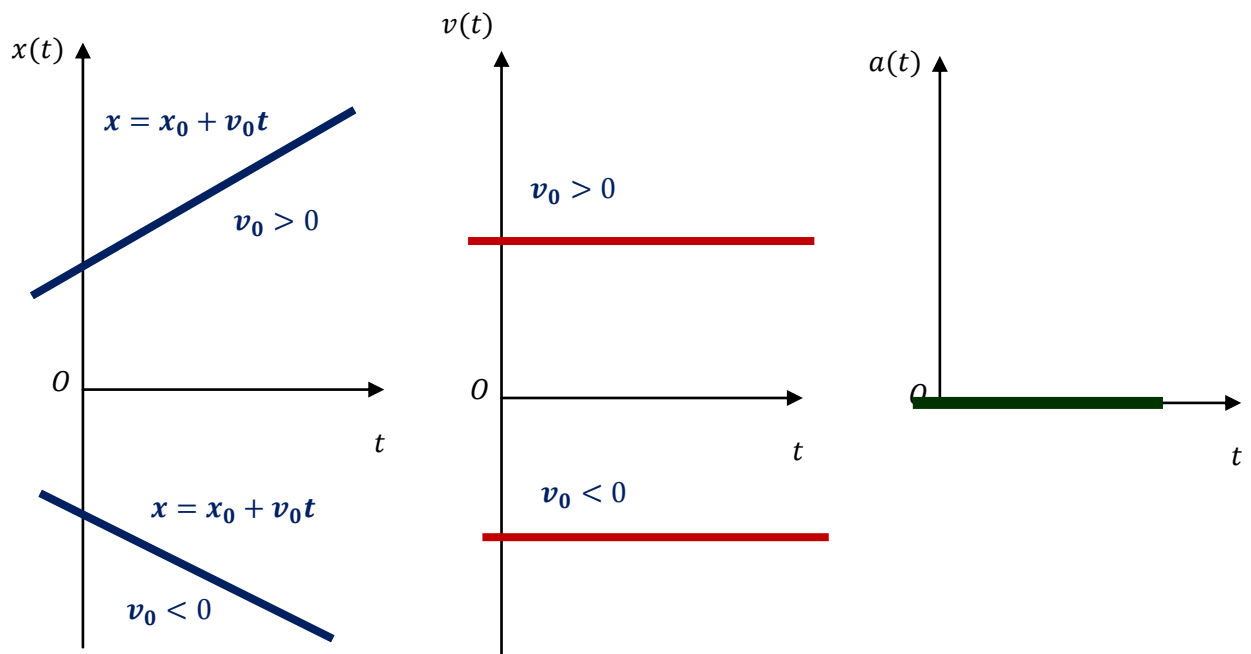

I.5.1.2. Uniformly varied rectilinear movement المتغيرة بانتظام الحركة المستقيمة

This movement of acceleration is constant at all times.

$$a = \frac{dv}{dt} = \frac{d^2x}{dt^2} = a_0 = cte$$

$$a = \frac{dv}{dt} = a_0 \Rightarrow dv = a_0 dt \Rightarrow \int_{v_0}^v dv = \int_{t_0}^t a_0 dt$$

$$\Rightarrow v - v_0 = a_0(t - t_0)$$

$$v = \frac{dx}{dt} = v_0 + a_0(t - t_0) \Rightarrow \int_{x_0}^x dx = \int_{t_0}^t v_0 dt + a_0 \int_{t_0}^t (t - t_0) dt$$

$$\Rightarrow x - x_0 = v_0(t - t_0) + \frac{1}{2} a_0(t - t_0)^2$$

$$x(t) = \frac{1}{2} a_0(t - t_0)^2 + v_0(t - t_0) + x_0$$

- case where $a_0 > 0$

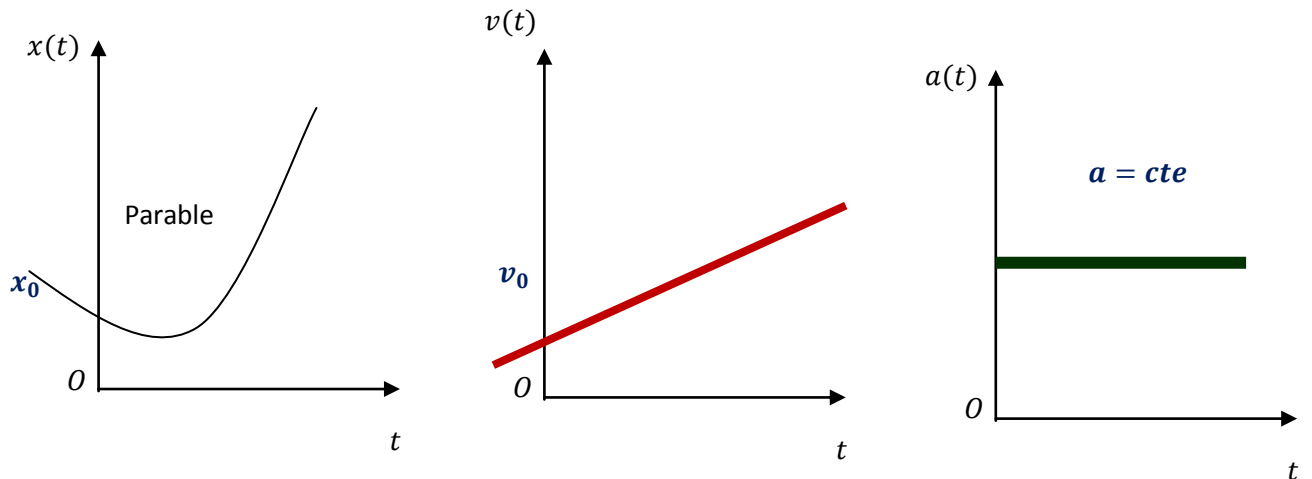

- case where $a_0 < 0$

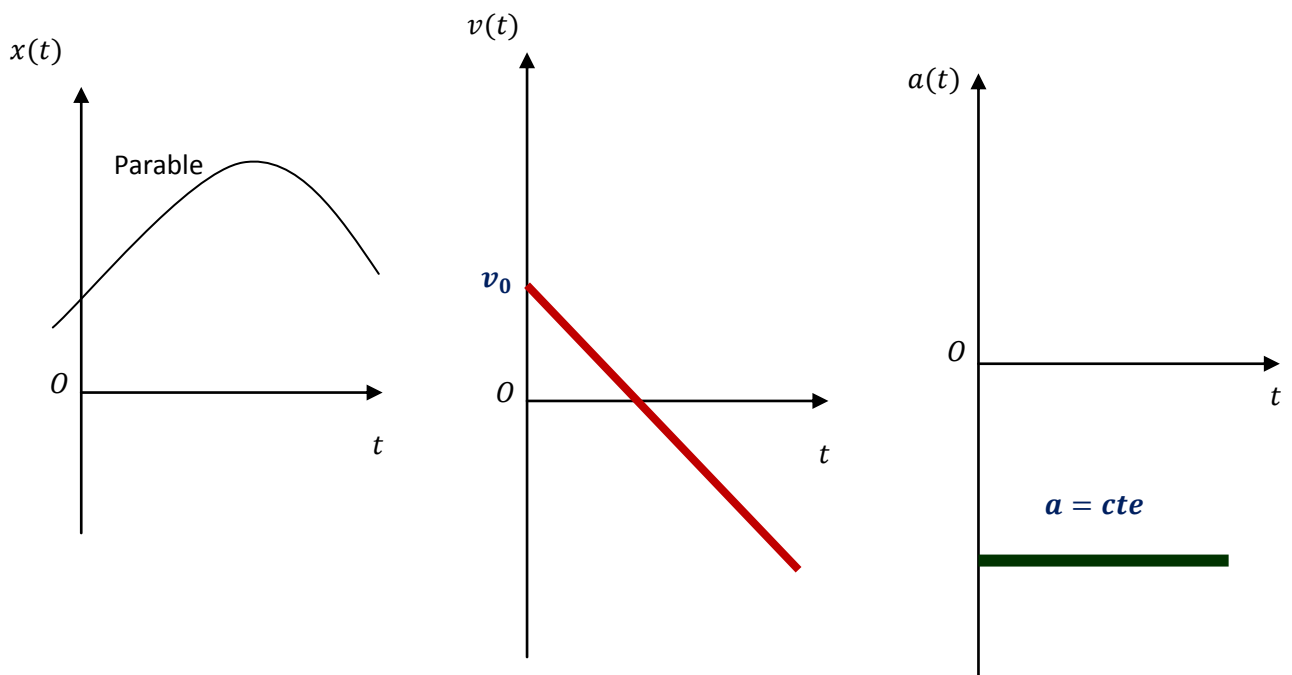

Note:

The movement is said to be accelerated (متسارعة) if $\vec{a} \cdot \vec{v} > 0$, and decelerated or delayed (متباطئة) if $\vec{a} \cdot \vec{v} < 0$. As for the direction of movement, it is indicated by the direction of the speed v .

I.5.2. Circular movement الحركة الدائرية

After moving the circle, the mobile phone will be replaced on a circle of rayon R and center O . It is préférable to use the base polaire.

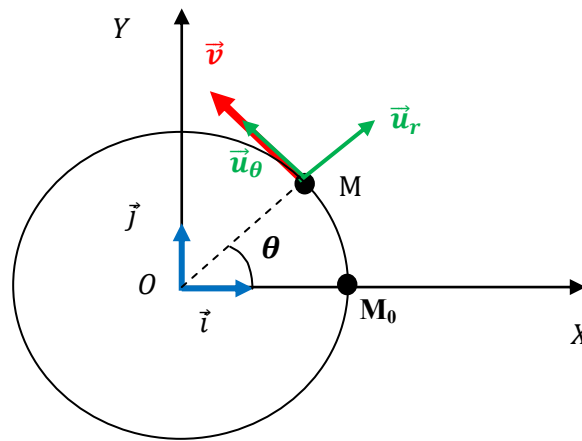
**a) Vector position:**

$$\vec{OM} = r \cdot \vec{u}_r = R \cdot \vec{u}_r$$

b) Vecteur vitesse:

$$\vec{v}(t) = \frac{d\vec{OM}}{dt} = \frac{d}{dt}(R \cdot \vec{u}_r) = \frac{dR}{dt} \vec{u}_r + R \frac{d\vec{u}_r}{dt} = R\dot{\theta} \vec{u}_\theta$$

$$\vec{v}(t) = R\dot{\theta} \vec{u}_\theta$$

c) Vecteur accélération:

$$\vec{a}(t) = \frac{d\vec{v}(t)}{dt} = \frac{d}{dt}(R\dot{\theta} \vec{u}_\theta) = R \frac{d^2\theta}{dt^2} \vec{u}_\theta + R \dot{\theta} \frac{d\vec{u}_\theta}{dt}$$

$$\vec{a}(t) = \frac{d\vec{v}(t)}{dt} = -R\dot{\theta}^2 \vec{u}_r + R\ddot{\theta} \vec{u}_\theta$$

I.5.2.1. Uniform circular movement

Circular motion is uniform if the angular velocity is a constant $\omega = \text{Cste}$

$$\theta = \omega t \Rightarrow \dot{\theta} = \omega = \text{cte} \Rightarrow \ddot{\theta} = 0$$

$\dot{\theta} = \omega$: angular velocity

$$\overrightarrow{OM} = R \cdot \overrightarrow{u_r}$$

$$\vec{v}(t) = \frac{d\overrightarrow{OM}}{dt} = R\omega\overrightarrow{u_\theta}$$

$$\vec{a}(t) = \frac{d\vec{v}(t)}{dt} = -R\omega^2\overrightarrow{u_r}$$

Then also read:

$$\theta = \dot{\theta}t + \theta_0$$

I.5.2.2. Uniformly varied circular movement

Circular motion is uniformly varied if the angular acceleration is a constant $\ddot{\theta} = \text{Cste}$

Angular acceleration $\ddot{\theta} = \text{cte}$

$$\ddot{\theta} = \dot{\theta}t + \theta_0$$

$$\theta = \frac{1}{2}\ddot{\theta}_0 t^2 + \dot{\theta}_0 t + \theta_0$$

Remark

The uniformly varied circular motion is either accelerated or retarded :

- The uniformly varied circular motion accelerated if the scalar product:

$$\ddot{\theta}_0 \cdot \dot{\theta}_0 > 0$$

- The uniformly varied circular motion retarded if the scalar product:

$$\ddot{\theta}_0 \cdot \dot{\theta}_0 < 0$$

I.6. Relative motion

II.6.1. Change of frames of reference

The study of the movement of a particle in all of the above was in a fixed (absolute) frame of reference R.

We can also choose another frame of reference R' in motion relative to the first, and determine the position, velocity and acceleration of the mobile.

- $R(O, \vec{i}, \vec{j}, \vec{k})$ fixed reference, which is called **absolute reference**.
- $R'(O', \vec{i}', \vec{j}', \vec{k}')$ in any movement relative to R which is called **relative reference**.

The movement of point M relative to “ R ” is called **absolute movement**.

- The movement of « R' » relative to « R » is called **entrainment movement**.

To determine the vectors: position, speed and acceleration, we have different methods: direct method and composition method

I.6.2. Direct method

I.6.2.1. Position vector

$$\overrightarrow{OM}_{/R} = x\vec{i} + y\vec{j} + z\vec{k}$$

I.6.2.2. Absolute velocity vector

$$\vec{v}_a(M) = \vec{v}(M)_{/R} = \left. \frac{d\overrightarrow{OM}}{dt} \right|_R = \frac{dx}{dt}\vec{i} + \frac{dy}{dt}\vec{j} + \frac{dz}{dt}\vec{k} = \dot{x}\vec{i} + \dot{y}\vec{j} + \dot{z}\vec{k}$$

$$\left. \frac{d\vec{i}}{dt} \right|_R = \vec{0}, \quad \left. \frac{d\vec{j}}{dt} \right|_R = \vec{0}, \quad \left. \frac{d\vec{k}}{dt} \right|_R = \vec{0}$$

I.6.2.3. Absolute acceleration vector

$$\vec{a}_a(M) = \vec{a}(M)_{/R} = \left. \frac{d\vec{v}_a}{dt} \right|_R = \left. \frac{d^2\overrightarrow{OM}}{dt^2} \right|_R = \frac{d^2x}{dt^2}\vec{i} + \frac{d^2y}{dt^2}\vec{j} + \frac{d^2z}{dt^2}\vec{k} = \ddot{x}\vec{i} + \ddot{y}\vec{j} + \ddot{z}\vec{k}_R$$

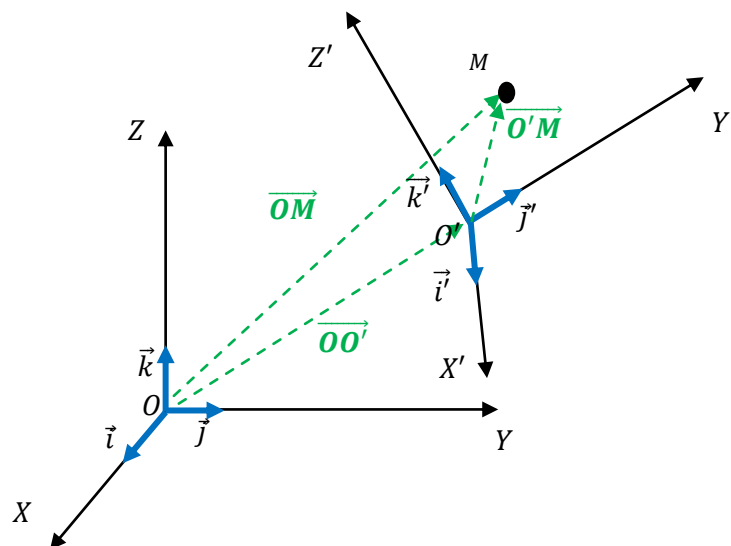

I.6.3. compound movement

I.6.3.1. position vector

$$\overrightarrow{OM} = \overrightarrow{OO'} + \overrightarrow{O'M}$$

\overrightarrow{OM} the movement of M relative to the absolute reference R

$\overrightarrow{O'M}$ the movement of M relative to the relative reference R'

$\overrightarrow{OO'}$ the movement of R' relative to the R (*translation and/or rotation*).

$$\overrightarrow{OM}_{/R} = x\vec{i} + y\vec{j} + z\vec{k}$$

$$\overrightarrow{O'M}_{/R'} = x'\vec{i}' + y'\vec{j}' + z'\vec{k}'$$

I.6.3.2. Absolute velocity vector: شعاع السرعة المطلقة

$$\vec{v}_a(M) = \left. \frac{d\overrightarrow{OM}}{dt} \right|_R = \left. \frac{d\overrightarrow{OO'}}{dt} \right|_R + \left. \frac{d\overrightarrow{O'M}}{dt} \right|_R = \left. \frac{d\overrightarrow{OO'}}{dt} \right|_R + \left. \frac{d}{dt} (x'\vec{i}' + y'\vec{j}' + z'\vec{k}') \right|_R$$

$$\vec{v}_a(M) = \frac{d\overrightarrow{OO'}}{dt} + \frac{dx'}{dt}\vec{i}' + \frac{dy'}{dt}\vec{j}' + \frac{dz'}{dt}\vec{k}' + x'\frac{d\vec{i}'}{dt} + y'\frac{d\vec{j}'}{dt} + z'\frac{d\vec{k}'}{dt}$$

$\vec{\omega} = \vec{\omega}_{(R'/R)}$ the angular velocity of R' with respect to R.

$$\left. \frac{d\vec{i}'}{dt} \right|_R = \vec{\omega}_{(R'/R)} \wedge \vec{i}'$$

$$\left. \frac{d\vec{j}'}{dt} \right|_R = \vec{\omega}_{(R'/R)} \wedge \vec{j}'$$

$$\left. \frac{d\vec{k}'}{dt} \right|_R = \vec{\omega}_{(R'/R)} \wedge \vec{k}'$$

$$\begin{aligned} \vec{v}_a(M) &= \frac{d\overrightarrow{OO'}}{dt} + x'\vec{\omega}_{(R'/R)} \wedge \vec{i}' + y'\vec{\omega}_{(R'/R)} \wedge \vec{j}' + z'\vec{\omega}_{(R'/R)} \wedge \vec{k}' + \frac{dx'}{dt}\vec{i}' + \frac{dy'}{dt}\vec{j}' \\ &\quad + \frac{dz'}{dt}\vec{k}' \end{aligned}$$

$$\vec{v}_a(M) = \frac{d\overrightarrow{OO'}}{dt} + \vec{\omega}_{(R'/R)} \wedge (x'\vec{i}' + y'\vec{j}' + z'\vec{k}') + \frac{dx'}{dt}\vec{i}' + \frac{dy'}{dt}\vec{j}' + \frac{dz'}{dt}\vec{k}'$$

$$\vec{v}_a(M) = \underbrace{\frac{d\overrightarrow{OO'}}{dt} + \vec{\omega}_{(R'/R)} \wedge \overrightarrow{O'M}}_{\vec{v}_e} + \underbrace{\left. \frac{d\overrightarrow{O'M}}{dt} \right|_{R'}}_{\vec{v}_r}$$

$$\boxed{\vec{v}_a(M) = \vec{v}_r + \vec{v}_e} \quad \text{absolute velocity}$$

$$\vec{v}_r = \left. \frac{d\overline{O'M}}{dt} \right|_{R'} : \text{relative velocity}$$

$$\vec{v}_e = \frac{d\overline{OO'}}{dt} + \vec{\omega}_{(R'/R)} \wedge \overline{O'M} : \text{entrainment velocity}$$

The movement of the R can be translated ($\frac{d\overline{OO'}}{dt}$) and rotated ($\vec{\omega}_{(R'/R)} \wedge \overline{O'M}$).

*Special cases:

- If M is fixed in R', $\vec{v}_r = \vec{0} \Rightarrow \vec{v}_a(M) = \vec{v}_e$
- If R' is fixed relative to R, $\vec{v}_e = \vec{0} \Rightarrow \vec{v}_a(M) = \vec{v}_r$
- If R' in translation movement relative to R, $\vec{\omega} = \vec{0} \Rightarrow \vec{v}_e = \frac{d\overline{OO'}}{dt}$
- If R' in rotational movement relative to R $\Rightarrow \vec{v}_e = \vec{\omega}_{(R'/R)} \wedge \overline{O'M}$

1.6.3.2. Absolute acceleration vector

$$\begin{aligned} \vec{a}_a(M) &= \left. \frac{d\vec{v}_a}{dt} \right|_R = \frac{d}{dt} \left(\left. \frac{d\overline{OO'}}{dt} + \vec{\omega}_{(R'/R)} \wedge \overline{O'M} + \vec{v}_r \right|_R \right) \\ &= \left. \frac{d^2\overline{OO'}}{dt^2} \right|_R + \frac{d}{dt} (\vec{\omega} \wedge \overline{O'M}) + \left. \frac{d\vec{v}_r}{dt} \right|_R \end{aligned}$$

$$\vec{a}_a(M) = \left. \frac{d^2\overline{OO'}}{dt^2} \right|_R + \frac{d\vec{\omega}}{dt} \wedge \overline{O'M} + \vec{\omega} \wedge \left. \frac{d\overline{O'M}}{dt} \right|_R + \vec{\omega} \wedge (\dot{x}'\vec{i}' + \dot{y}'\vec{j}' + \dot{z}'\vec{k}') + \left. \frac{d^2\overline{O'M}}{dt^2} \right|_{R'}$$

We note that: $\left. \frac{d\overline{O'M}}{dt} \right|_R = \vec{\omega} \wedge \overline{O'M} + \left. \frac{d\overline{O'M}}{dt} \right|_{R'}$ (see previous section)

$$\begin{aligned} \left. \frac{d\vec{v}_r}{dt} \right|_R &= \frac{d}{dt} \left(\frac{dx'}{dt} \vec{i}' + \frac{dy'}{dt} \vec{j}' + \frac{dz'}{dt} \vec{k}' \right) \\ &= \dot{x}' \vec{\omega} \wedge \vec{i}' + \dot{y}' \vec{\omega} \wedge \vec{j}' + \dot{z}' \vec{\omega} \wedge \vec{k}' + \frac{d\dot{x}'}{dt} \vec{i}' + \frac{d\dot{y}'}{dt} \vec{j}' + \frac{d\dot{z}'}{dt} \vec{k}' \end{aligned}$$

$$\left. \frac{d\vec{v}_r}{dt} \right|_R = \vec{\omega} \wedge (\vec{v}_r) + \left. \frac{d\vec{v}_r}{dt} \right|_{R'}$$

$$\vec{a}_a(M) = \left. \frac{d^2 \overline{OO'}}{dt^2} \right|_R + \frac{d\vec{\omega}}{dt} \wedge \overline{O'M} + \vec{\omega} \wedge (\vec{\omega} \wedge \overline{O'M} + \vec{v}_r) + \vec{\omega} \wedge (\vec{v}_r) + \left. \frac{d\vec{v}_r}{dt} \right|_{R'}$$

$$\vec{a}_a(M) = \left. \frac{d^2 \overline{OO'}}{dt^2} \right|_R + \frac{d\vec{\omega}}{dt} \wedge \overline{O'M} + \vec{\omega} \wedge (\vec{\omega} \wedge \overline{O'M}) + \vec{\omega} \wedge \vec{v}_r + \vec{\omega} \wedge (\vec{v}_r) + \left. \frac{d\vec{v}_r}{dt} \right|_{R'}$$

$$\vec{a}_a(M) = \underbrace{\left. \frac{d^2 \overline{OO'}}{dt^2} + \frac{d\vec{\omega}}{dt} \wedge \overline{O'M} + \vec{\omega} \wedge (\vec{\omega} \wedge \overline{O'M}) \right|_R}_{\vec{a}_e} + \underbrace{2\vec{\omega} \wedge \vec{v}_r}_{\vec{a}_c} + \underbrace{\left. \frac{d\vec{v}_r}{dt} \right|_{R'}}_{\vec{a}_r}$$

$$\boxed{\vec{a}_a = \vec{a}_r + \vec{a}_e + \vec{a}_c}$$

\vec{a}_a : **Absolute accélération**

$\vec{a}_r = \left. \frac{d\vec{v}_r}{dt} \right|_{R'}$: **relative accélération**

$\vec{a}_e = \left. \frac{d^2 \overline{OO'}}{dt^2} \right|_R + \frac{d\vec{\omega}}{dt} \wedge \overline{O'M} + \vec{\omega} \wedge (\vec{\omega} \wedge \overline{O'M})$: **Entrainement accélération**

$\vec{a}_c = 2\vec{\omega} \wedge \vec{v}_r$: **Coriolis accélération**

Exercises

Exercise 1

The movement of a point M is given by the following time equations:

$$\begin{cases} x = t^2 \\ y = 2t^2 + 1 \end{cases}$$

-Determine the equation of motion and the nature of the trajectory, represent this trajectory graphically.

Exercise 2

The motion of a point M is given by the following time equations:

$$\begin{cases} x = t \\ y = 2t^2 + 1 \\ z = -3t \end{cases}$$

- Determine the vectors of velocity and acceleration of particle M.

Exercise 3

The movement of a point M is described in polar coordinates by: $r(\theta) = R \cdot \sin\theta$

$\theta = \omega t$ et R , ω are positive constants.

1- Calculate the components of the velocity: v_r and v_θ

2- Calculate the components of the acceleration: a_r and a_θ

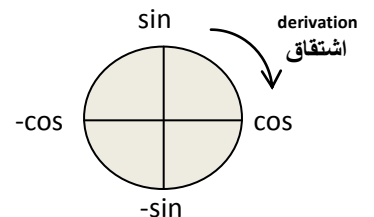

Exercise 4

A material point M is moving along the (OX) axis with an acceleration a_x as represented

in the graph below. It is assumed that at $t = 0$, $v_x = 0$, and $x = 0$.

1) (a) Find the expressions for the velocity $v_x(t)$ during the different phases of the motion.

(b) Graphically represent $v_x(t)$ during all phases.

(c) Determine the instants t_1 and t_2 when the object changes the direction of motion.

2) (a) Find the expressions for the position $x(t)$ of the object during the different phases of the motion.

(b) Determine the nature of the motion between $t = 0$ and $t = 7$ s.

Exercise 6

Consider the absolute reference frame $R_1(O_1X_1Y_1Z_1)$ and the relative reference frame $R(OXYZ)$ which rotates around the axis O_1X_1 with an angular speed constant ω ($OX \equiv O_1X_1$). Let (D) be a fixed line in the frame R, parallel to OY and passing through point A, with $\overrightarrow{OA} = b\vec{k}$ ($b = \text{cte}$).

Let M be a point moving along the line (D) according to the relation:

$$\overrightarrow{AM} = \frac{1}{2}at^2\vec{j}$$

($a = \text{cte}$)

-Calculate the absolute velocity and acceleration of point M in the relative reference frame R, using the:

1. Direct method.
2. The method of composing velocities and accelerations.

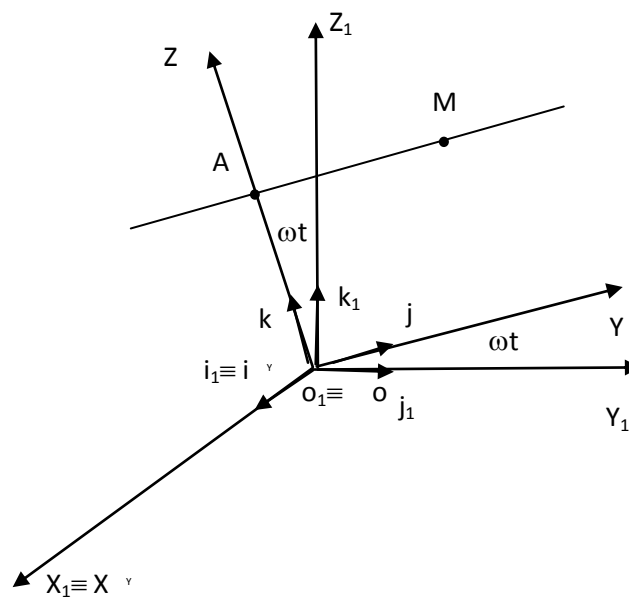

Solution

Exercise 1

$$\begin{cases} x = t^2 \\ y = 2t^2 + 1 \end{cases}$$

We have $x = t^2$ we replace it in the equation of $y = 2t^2 + 1$ so : $y = 2x^2 + 1$

$$\boxed{y = 2x^2 + 1}$$

The trajectory is a line that does not pass through the origin.

x	0	-1/2
y	1	0

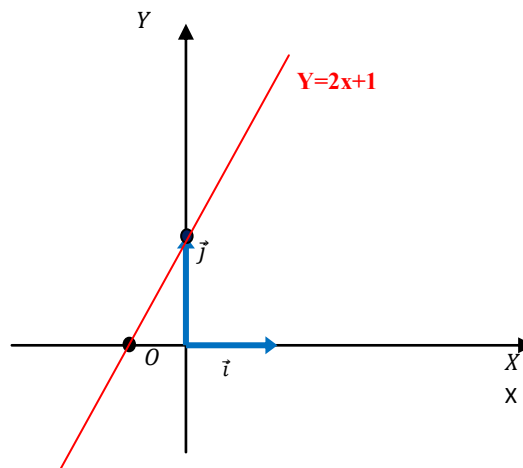

Exercise 2

1-Velocity:

$$\vec{v} = \frac{d\vec{OM}}{dt} = \dot{x}\vec{i} + \dot{y}\vec{j} + \dot{z}\vec{k} = v_x\vec{i} + v_y\vec{j} + v_z\vec{k}$$

$$\vec{OM} = x\vec{i} + y\vec{j} + z\vec{k} = t\vec{i} + 2t^2\vec{j} + 3t\vec{k} \Rightarrow \vec{v} = \begin{cases} v_x = \frac{dx}{dt} = 1 \\ v_y = \frac{dy}{dt} = 4t \\ v_z = \frac{dz}{dt} = -3 \end{cases}$$

$$\boxed{\vec{v} = \vec{i} + 4t\vec{j} - 3\vec{k}}$$

2-Acceleration:

$$\vec{a} = \frac{d\vec{v}}{dt} = \dot{v}_x \vec{i} + \dot{v}_y \vec{j} + \dot{v}_z \vec{k}$$

$$\Rightarrow \vec{a} = \begin{cases} v_x = \frac{dx}{dt} = 0 \\ v_y = \frac{dy}{dt} = 4 \\ v_z = \frac{dz}{dt} = 0 \end{cases}$$

$$\boxed{\vec{a} = 4\vec{j}}$$

Exercise 3

1- Velocity in polar coordinates:

$$\vec{v}(t) = \frac{dr}{dt} \vec{u}_r + r \frac{d\theta}{dt} \vec{u}_\theta = \dot{r} \vec{u}_r + r\dot{\theta} \vec{u}_\theta \Rightarrow \begin{cases} v_r = R\omega \cdot \cos\theta \\ v_\theta = R\omega \cdot \sin\theta \end{cases}$$

$$r = R \cdot \sin\theta \Rightarrow \dot{r} = R \cdot \dot{\theta} \cdot \cos\theta = R \cdot \omega \cdot \cos\theta$$

$$\frac{d\theta}{dt} = \dot{\theta} = \omega$$

$$\boxed{\vec{v} = \begin{cases} v_r = R\omega \cdot \cos\theta \\ v_\theta = R\omega \cdot \sin\theta \end{cases}}$$

2- Acceleration in polar coordinates:

$$\vec{a}(t) = \frac{d\vec{v}(t)}{dt} = (\ddot{r} - r\dot{\theta}^2) \vec{u}_r + (2\dot{r}\dot{\theta} + r\ddot{\theta}) \vec{u}_\theta \Rightarrow \begin{cases} a_r = -2R\omega^2 \cdot \sin\theta \\ a_\theta = 2R\omega^2 \cdot \cos\theta \end{cases}$$

$$\boxed{\vec{a}(t) \begin{cases} a_r = -2R\omega^2 \cdot \sin\theta \\ a_\theta = 2R\omega^2 \cdot \cos\theta \end{cases}}$$

Exercise 4

1) (a) The expressions for the velocity $v(t)$:

$$a = \frac{dv}{dt} \Rightarrow dv = a dt$$

$$\Rightarrow v(t) = \int a(t) dt$$

• For $t \in [0, 1]$: $a(t) = 1 \text{ m/s}^2 \Rightarrow v(t) = \int dt = t + C_1$

At $t = 0 \text{ s}$, $v = 0 \text{ m/s} \Rightarrow C_1 = 0 \Rightarrow v(t) = t$

• For $t \in [1, 3]$: $a(t) = 0 \text{ m/s}^2 \Rightarrow v(t) = C_2$.

At $t = 1 \text{ s}$, $v = 1 \text{ m/s} \Rightarrow C_2 = 1 \Rightarrow v(t) = 1 \text{ m/s}$

• For $t \in [3, 6]$: $a(t) = -1 \text{ m/s}^2 \Rightarrow v(t) = -\int dt = -t + C_3$

At $t = 3 \text{ s}$, $v = 1 \text{ m/s} \Rightarrow C_3 = 4 \Rightarrow v(t) = -t + 4$

• For $t \in [6, 7]$: $a(t) = 2 \text{ m/s}^2 \Rightarrow v(t) = \int 2 dt = 2t + C_4$

At $t = 6 \text{ s}$, $v = -14 \text{ m/s} \Rightarrow C_4 = -14 \Rightarrow v(t) = 2t - 14$

(b) Graphical representation of $v(t)$ during all phases:

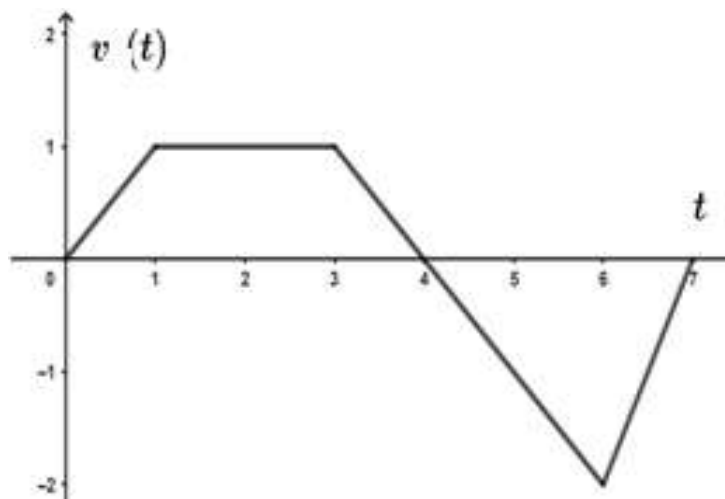

2) (a) The expressions for the position $x(t)$:

$$v = \frac{dx}{dt} \Rightarrow dx = v dt \Rightarrow x(t) = \int v(t) dt$$

• For $t \in [0, 1]$: $v(t) = t \Rightarrow x(t) = \int t dt \Rightarrow x(t) = \frac{1}{2}t^2 + C_1$

At $t = 0$ s, $x = 0$ m $\Rightarrow C_1 = 0 \Rightarrow x(t) = \frac{1}{2}t^2$

• For $t \in [1, 3]$: $v(t) = 1$ m/s $\Rightarrow x(t) = \int dt \Rightarrow x(t) = t + C_2$

At $t = 1$ s, $x = 1/2$ m $\Rightarrow 1/2 = 1 + C_2 \Rightarrow C_2 = -1/2 \Rightarrow x(t) = t - \frac{1}{2}$

• For $t \in [3, 6]$: $v(t) = -t+4 \Rightarrow x(t) = \int(-t+4)dt \Rightarrow x(t) = \frac{-t^2}{2} + 4t + C_3$

At $t = 3$ s, $x = 5/2$ m $= 15/2 + C_3 \Rightarrow C_3 = -5 \Rightarrow x(t) = \frac{-t^2}{2} + 4t - 5$

• For $t \in [6, 7]$: $v(t) = 2t - 14 \Rightarrow x(t) = \int 2t - 14)dt \Rightarrow x(t) = t^2 - 14t + C_4$

At $t = 6$ s, $x = 1$ m $= -48 + C_4 \Rightarrow C_4 = 49 \Rightarrow x(t) = t^2 - 14t + 49$

(b) The nature of the motion between $t = 0$ and $t = 3$ s:

- $t \in [0, 1]$: $a.v = t > 0 \Rightarrow$ uniformly accelerated rectilinear motion .
- $t \in [1, 3]$: $a.v = 0 \Rightarrow$ uniform rectilinear motion.

Exercise 5

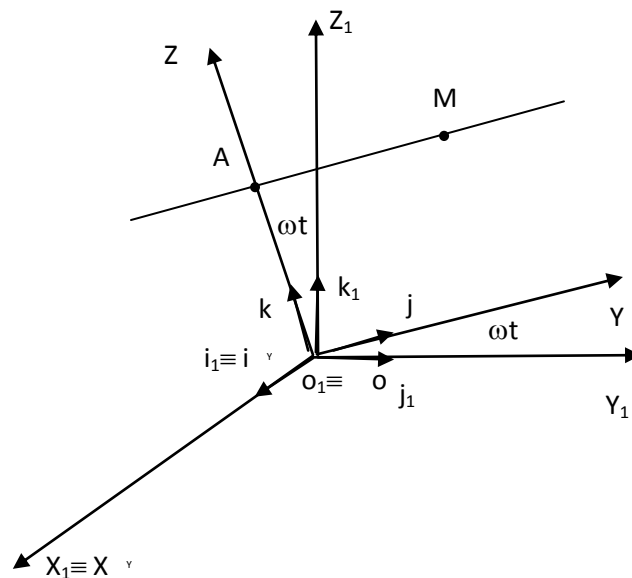

Position vector

$$\overrightarrow{O_1M} = \overrightarrow{OM} = \overrightarrow{OA} + \overrightarrow{AM}$$

$$\overrightarrow{OA} = b \cdot \vec{k}$$

$$\overrightarrow{AM} = \frac{1}{2}at^2 \cdot \vec{j}$$

$$\overrightarrow{O_1M} = \overrightarrow{OM} = \frac{1}{2}at^2 \cdot \vec{j} + b \cdot \vec{k}$$

$$\vec{\omega} = \omega \vec{i}$$

1. Calculate absolute velocity \vec{v}_a and absolute accélération \vec{a}_a using direct method:

1.a. Absolute velocity \vec{v}_a

$$\vec{v}_a(M) = \vec{v}(M) /_{R_1} = \left. \frac{d\overline{O_1M}}{dt} \right|_{R_1} = \left. \frac{d}{dt} \left(\frac{1}{2} at^2 \cdot \vec{j} + b \cdot \vec{k} \right) \right|_{R_1}$$

$$\vec{v}_a(M) = \left. \frac{d\overline{O_1M}}{dt} \right|_{R_1} = at \cdot \vec{j} + \frac{1}{2} at^2 \left. \frac{d\vec{j}}{dt} \right|_{R_1} + b \cdot \left. \frac{d\vec{k}}{dt} \right|_{R_1}$$

$$\vec{\omega} = \omega \vec{i}$$

$$\left. \frac{d\vec{j}}{dt} \right|_{R_1} = \vec{\omega}_{(R/R_1)} \wedge \vec{j} = \omega \vec{i} \wedge \vec{j} = \omega \vec{k}$$

$$\left. \frac{d\vec{k}}{dt} \right|_{R_1} = \vec{\omega}_{(R/R_1)} \wedge \vec{k} = \omega \vec{i} \wedge \vec{k} = -\omega \vec{j}$$

$$\vec{v}_a(M) = at \cdot \vec{j} + \frac{1}{2} at^2 \omega \vec{k} - b\omega \vec{j}$$

$$\boxed{\vec{v}_a(M) = (at - b\omega) \cdot \vec{j} + \frac{1}{2} a\omega t^2 \cdot \vec{k}}$$

1.b. Absolute accélération \vec{a}_a

$$\vec{a}_a(M) = \vec{a}(M) /_{R_1} = \left. \frac{d\vec{v}_a}{dt} \right|_{R_1} = \left. \frac{d^2 \overline{O_1M}}{dt^2} \right|_{R_1} = \left. \frac{d}{dt} \left((at - b\omega) \cdot \vec{j} + \frac{1}{2} at^2 \omega \cdot \vec{k} \right) \right|_{R_1}$$

$$\vec{a}_a(M) = a \cdot \vec{j} + (at - b\omega) \left. \frac{d\vec{j}}{dt} \right|_{R_1} + a\omega t \cdot \vec{k} + \frac{1}{2} a\omega t^2 \cdot \left. \frac{d\vec{k}}{dt} \right|_{R_1}$$

$$\vec{a}_a(M) = a \cdot \vec{j} + (at - b\omega) \omega \vec{k} + a\omega t \cdot \vec{k} - \frac{1}{2} a\omega t^2 \cdot \omega \vec{j}$$

$$\boxed{\vec{a}_a(M) = \left(a - \frac{1}{2} a\omega^2 t^2 \right) \cdot \vec{j} + (2a\omega t - b\omega^2) \vec{k}}$$

2. Calculate absolute velocity \vec{v}_a and absolute accélération \vec{a}_a using composing method:

2.a. absolute velocity \vec{v}_a

$$\vec{v}_a(M) = \vec{v}_r + \vec{v}_e$$

$$\vec{v}_r = \left. \frac{d\overline{OM}}{dt} \right|_R = \left. \frac{d}{dt} \left(\frac{1}{2} at^2 \cdot \vec{j} + b \cdot \vec{k} \right) \right|_R$$

$$\boxed{\vec{v}_r = at \cdot \vec{j}}$$

$$\vec{v}_e = \left. \frac{d\overline{O_1O}}{dt} \right|_{R_1} + \vec{\omega}_{(R/R_1)} \wedge \overline{OM}$$

$$\vec{v}_e = \vec{0} + \omega \vec{i} \wedge \left(\frac{1}{2} at^2 \cdot \vec{j} + b \cdot \vec{k} \right)$$

$$\vec{v}_e = \frac{1}{2} a\omega t^2 \cdot \vec{k} - b\omega \cdot \vec{j}$$

$$\boxed{\vec{v}_e = -b\omega \cdot \vec{j} + \frac{1}{2} a\omega t^2 \cdot \vec{k}}$$

$$\vec{v}_a(M) = \vec{v}_r + \vec{v}_e$$

$$\vec{v}_a(M) = at \cdot \vec{j} + \left(-b\omega \cdot \vec{j} + \frac{1}{2} a\omega t^2 \cdot \vec{k} \right)$$

$$\boxed{\vec{v}_a(M) = (at - b\omega) \cdot \vec{j} + \frac{1}{2} a\omega t^2 \cdot \vec{k}}$$

2.b. Absolute accélération \vec{a}_a

$$\vec{a}_a = \vec{a}_r + \vec{a}_e + \vec{a}_c$$

$$\vec{a}_r = \left. \frac{d\vec{v}_r}{dt} \right|_R$$

$$\vec{a}_r = \left. \frac{d}{dt} (at \cdot \vec{j}) \right|_R = a\vec{j}$$

$$\boxed{\vec{a}_r = a\vec{j}}$$

$$\vec{a}_e = \left. \frac{d^2\overline{O_1O}}{dt^2} \right|_{R_1} + \frac{d\vec{\omega}}{dt} \wedge \overline{OM} + \vec{\omega} \wedge (\vec{\omega} \wedge \overline{OM})$$

$$\vec{\omega} = \overline{cst} \Rightarrow d\vec{\omega} = \vec{0}$$

$$\vec{a}_e = \vec{0} + \vec{0} \wedge \overline{OM} + \omega \vec{i} \wedge \left(\omega \vec{i} \wedge \left(\frac{1}{2} at^2 \cdot \vec{j} + b \cdot \vec{k} \right) \right)$$

$$\vec{a}_e = \omega \vec{i} \wedge \left(\frac{1}{2} a \omega t^2 \vec{k} - \omega b \cdot \vec{j} \right)$$

$$\boxed{\vec{a}_e = -\frac{1}{2} a \omega^2 t^2 \vec{j} - \omega^2 b \cdot \vec{k}}$$

$$\vec{a}_c = 2\vec{\omega} \wedge \vec{v}_r$$

$$\vec{a}_c = 2\omega \vec{i} \wedge at \cdot \vec{j} = 2\omega at \cdot \vec{k}$$

$$\boxed{\vec{a}_c = 2\omega at \cdot \vec{k}}$$

$$\vec{a}_a = \vec{a}_r + \vec{a}_e + \vec{a}_c$$

$$\boxed{\vec{a}_a(M) = \left(a - \frac{1}{2} a \omega^2 t^2 \right) \cdot \vec{j} + (2\omega at - b\omega^2) \vec{k}}$$

Chapter 2

Dynamics of a particle

II.1. Introduction

In the previous chapter we studied the movement of bodies without taking into account the causes which provoke the movement. In this chapter (dynamics) we study the causes of movement, which are forces.

Dynamics is the analysis of the relationship between forces applied to a body and changes in the movement of this body. It explains the relationship that exists between forces and other quantities.

II.2. Definition

II.2.1. Concept of force

The movement is the result of the interaction between the particle and its environment. This interaction is the force (vector quantity).

The unit of force in SI is the Newton: $1\text{N} = 1\text{Kg.m.s}^{-2}$

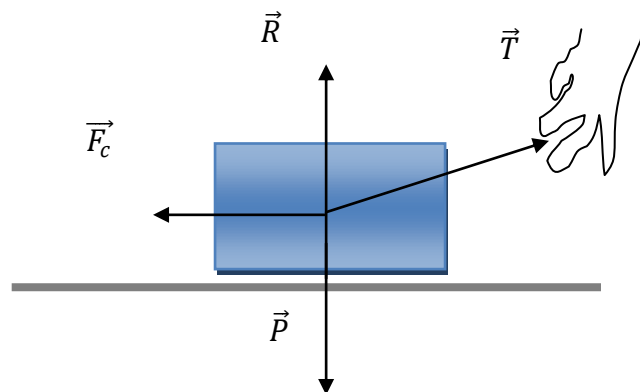

There are two main categories of forces:

a- Contact forces: friction forces, tension forces, etc.

b- Forces at a distance: gravitational forces, electric forces, magnetic forces.

Example: a body slides on a horizontal surface by a wire.

II.2.2. Mass

Mass is a scalar physical quantity that represents the quantity of matter which makes up a particle, and it represents the inertia of the body.

The unit of mass in SI is kg

II.2.3. Material point

We call a material point or point mass a mechanical system that can be modelled by a geometric point M with which its mass m is associated.

Material system: is a set of material points.

We freely choose the system we study. Anything other than the system being studied is called the exterior.

II.2.4. Isolated or pseudo-isolated system

A system is isolated if it is not subject to any external force.

A system is pseudo isolated if the Σ of the external forces applied to this system is zero:

$$\Sigma F = 0$$

II.3. Momentum

A movement of a body does not depend only on the speed but also on its mass, two different masses which move at the same speed do not arrive in the same way. For this we introduce a quantity which is the momentum \vec{P} .

The momentum relative to the reference frame R of a material point M , of mass m and speed \vec{v} is given by:

$$\vec{P} = m\vec{v}$$

Unit: kg.m/s; dimension: [momentum] = MLT^{-1}

II.3.1 Conservation of quantity of movement:

If we have a system composed of N particles of masses m_i and speeds \vec{V}_i , then the total momentum of the system is given by:

$$\vec{P} = \sum_{i=1}^N \vec{P}_i = \vec{P}_1 + \vec{P}_2 + \vec{P}_3 + \dots$$

For an isolated system this momentum is constant:

$$\vec{P} = \sum_{i=1}^N \vec{P}_i = cst$$

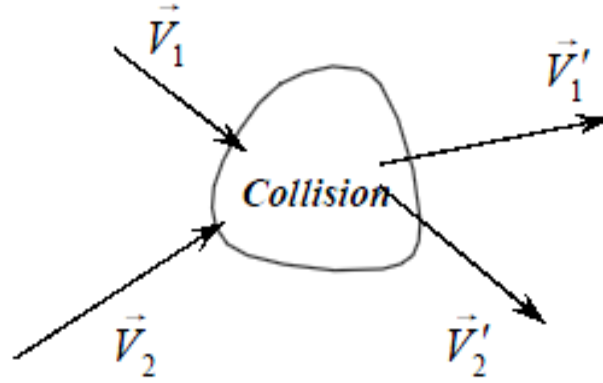

II.3.2. Case of two particles in collision

Consider a system of two particles m_1 and m_2 .

Before the collision the speeds are noted V_1 and V_2 .

$$\vec{P} = \vec{P}_1 + \vec{P}_2 = m_1 \vec{v}_1 + m_2 \vec{v}_2$$

After the collision the speeds are noted as V'_1 and V'_2 .

$$\vec{P}' = \vec{P}'_1 + \vec{P}'_2 = m_1 \vec{v}'_1 + m_2 \vec{v}'_2$$

Conservation of momentum:

$$\begin{aligned} \vec{P} = \vec{P}' &\Rightarrow \vec{P}_1 + \vec{P}_2 = \vec{P}'_1 + \vec{P}'_2 \Rightarrow \vec{P}_1 - \vec{P}'_1 = \vec{P}'_2 - \vec{P}_2 \\ &\Rightarrow \Delta \vec{P}_1 = -\Delta \vec{P}_2 \end{aligned}$$

An interaction produces an **exchange of momentum**. The quantity of movement “**lost**” by one particle is equal to the momentum “**gained**” by the other.

II.4. Fundamental Laws of Dynamics القوانين الأساسية في الديناميك

II.4.1. 1st Newton's law ‘Principle of Inertia’ مبدأ العطالة

a. Statement of principle: نص المبدأ

If the material body is not subjected to any force or the vector resultant of the applied forces is zero, it is:

- ❖ in a uniform rectilinear movement ($v = cst$ and $a=0$) حركة مستقيمة منتظمة
- ❖ at rest (في السكون), if it was initially at rest ($v=0$).

This property of all bodies to resist change in speed (zero acceleration) is called inertia.

Example:

The movements of passengers caused by vehicles when starting and braking.

b. Galilean frame of reference معلم غاليلي

An inertia reference frame is a reference frame in which the principle of inertia is realized. *i.e.*, it keeps its inertia: it remains at rest if it is at rest and it keeps its uniform rectilinear movement as long as $\sum \vec{F} = \vec{0}$.

Note:

Any frame of reference in uniform rectilinear translation with respect to a Galilean frame of reference is itself Galilean.

The earth's reference frame is not really Galilean because of its movement. But we consider it to be a Galilean reference because we carry out studies with low times.

Example on a non-Galilean frame of reference:

An object placed in a truck in uniform rectilinear motion. The body remains immobile in relation to the truck as long as the latter's movement maintains its uniform rectilinear character. When the truck executes a movement in a turn, the body would slide. Indeed, the reference linked to the truck is animated by a curvilinear movement and the principle of inertia is no longer applicable (the object would not maintain its state of rest in relation to the truck).

Note:

The principle of inertia can then be stated as follows: “A free particle moves with a constant quantity of movement in a Galilean frame of reference. »

$$\vec{P} = \overrightarrow{cst} \Rightarrow \vec{F} = \frac{d\vec{P}}{dt} = \vec{0}$$

This is another formulation of the principle of inertia.

II.4.2. 2nd Newton's Law: ‘Fundamental Relation of Dynamics (FRD)’

The resultant of the forces exerted on a body is the derivative of the momentum:

$$\sum \vec{F}_{ext} = \frac{d\vec{P}}{dt} = \frac{d(m\vec{v})}{dt}$$

If the mass of the system is constant then:

$$\sum \vec{F}_{ext} = m \frac{d\vec{v}}{dt} = m\vec{a}$$

II.4.3. 3rd Newton's Law: 'Principle of reciprocal actions'

Given that M_1 and M_2 two material points, \vec{F}_{12} and \vec{F}_{21} the reciprocal interaction forces, applied by M_1 on M_2 and that applied by M_2 on M_1 , respectively.

The principle of reciprocal actions, also called the principle of action \vec{F}_{12} and the reaction \vec{F}_{21} , states that:

- These two actions (forces) are exerted simultaneously and are of the same nature
- These two forces are opposite $\vec{F}_{12} = -\vec{F}_{21}$ and equal in moduli $\|\vec{F}_{12}\| = \|\vec{F}_{21}\|$.
- \vec{F}_{12} and \vec{F}_{21} are belong to the same segment $[M_1M_2]$:
 $\vec{F}_{12} \wedge \overline{M_1M_2} = \vec{0}$, $\vec{F}_{21} \wedge \overline{M_1M_2} = \vec{0}$



Remark:

Isolated system: In the case of the system $\{M_1, M_2\}$ is isolate (in R reference frame):

$$\vec{F}_{21} = \frac{d\vec{P}_1}{dt} \text{ and } \vec{F}_{12} = \frac{d\vec{P}_2}{dt}$$

$$\vec{F}_{12} = -\vec{F}_{21} \Rightarrow \frac{d\vec{P}_2}{dt} = -\frac{d\vec{P}_1}{dt}$$

$$\frac{d\vec{P}_1}{dt} + \frac{d\vec{P}_2}{dt} = \vec{0} \rightarrow \frac{d}{dt}(\vec{P}_1 + \vec{P}_2) = \vec{0}$$

$$(\vec{P}_1 + \vec{P}_2) = \overrightarrow{P_{\{M_1, M_2\}}} = \overrightarrow{cst}$$

The momentum of an isolated system is conserved.

II.5. Classification of forces

II.5.1. Forces at a distance

The body which exerts the force is not in contact with the one on which it acts.

There are 3 kinds of forces at a distance:

a) Gravitational forces:

This is the action of one mass (body) on another. These two bodies attract each other mutually with two opposing forces (according to Newton's 3rd law): $\vec{F}_{12} = -\vec{F}_{21}$

It's the **Law of universal gravitation** which explains attraction between two bodies of respective masses m_1 and m_2 , separated by distance d .

$$F_{12} = F_{21} = F_g = G \frac{m_1 m_2}{d^2}$$

These forces are attractive.

G : the gravitational constant, $G = 6.67 \cdot 10^{-11} \text{ [m}^3/\text{kg}\cdot\text{s}^2\text{]}$

Near the earth, the force of gravitation is what keeps objects on the ground.

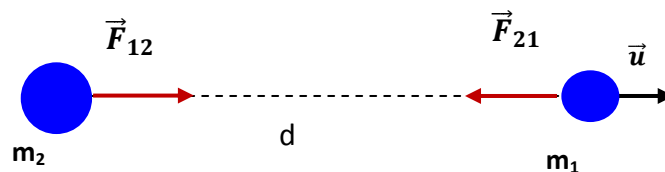

b) Weight of a mass:

Consider a point mass m , in gravitational interaction with Earth. The latter acts on the mass with a force that we called the weight of the mass. Newton's second law allows us to define this weight:

$$\vec{P} = m\vec{g}$$

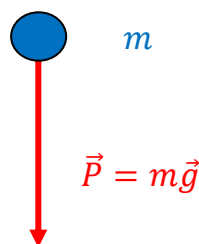

\vec{g} is the acceleration of gravity (terrestrial acceleration), $g=9.80 \text{ m/s}^2$.

c) Electric forces:

They are exerted between two bodies carrying electrical charges. They can be both attractive or repulsive.

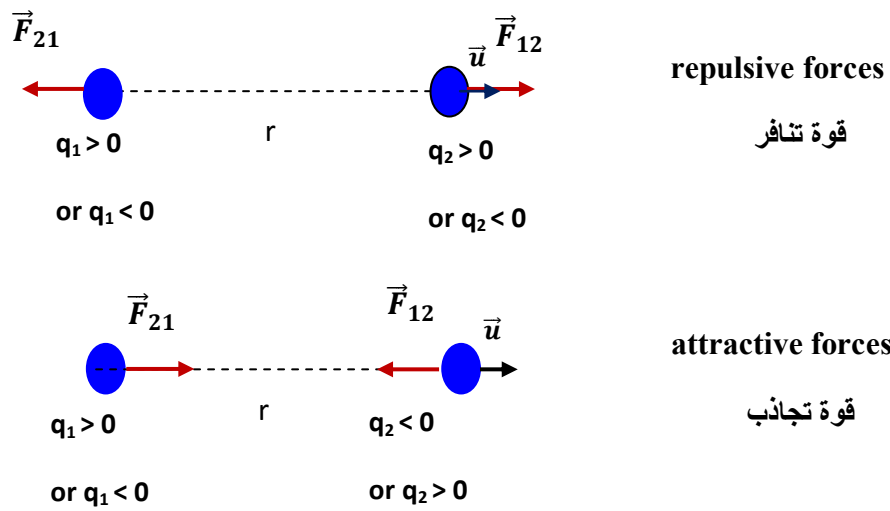

d) Magnetic forces:

They are exerted between magnets or between the latter and certain materials (particularly iron). Both can be attractive or repulsive.

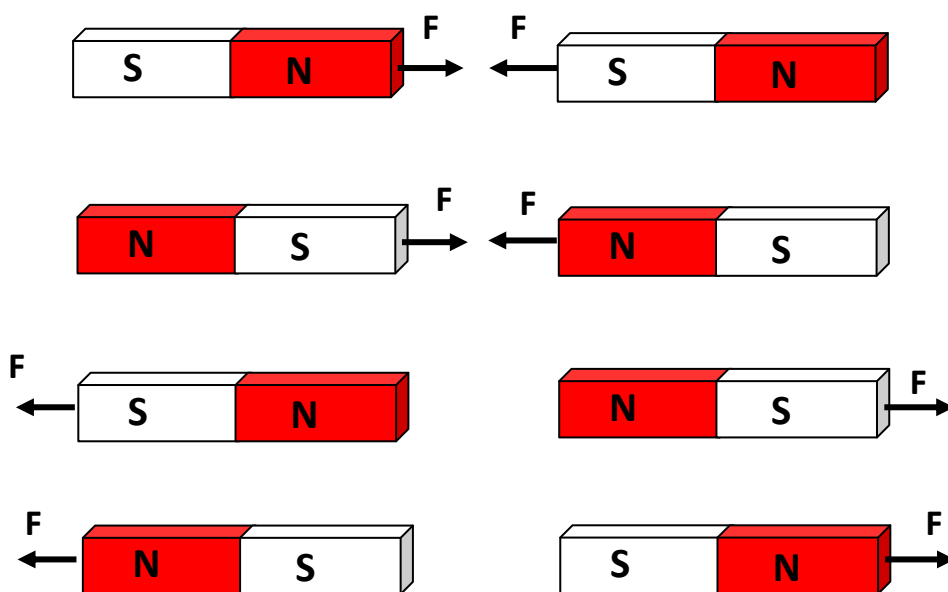

II.5.2. Contact forces

There must be contact between the two objects for a contact force to arise.

a) Reaction of a support (Solid-solid contact)

The force acting on an object placed on a horizontal support is called the support reaction, \vec{R}_n . Represents the result of all actions performed on the contact surface.

The object being in equilibrium:

$$\sum \vec{F}_{ext} = \vec{P} + \vec{R}_n = \vec{0} \Rightarrow \vec{P} = -\vec{R}_n$$

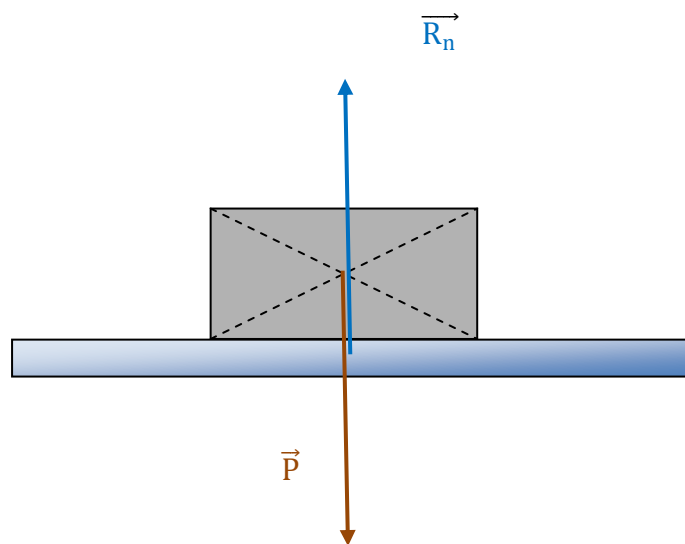

b) Friction force

Friction force is the force that opposes the movement of the body. There are two friction forces: solid and fluid.

□ **Solid–Solid friction:** dynamic friction force (the body is moving):

When the solid moves under the action of an external force \vec{F}_e , the intensity f_d of the friction force is proportional to that of the reaction normal to the support \vec{R}_n .

$$\vec{f}_d = \mu_d \vec{R}_n$$

μ_d : the dynamic friction coefficient معامل الاحتكاك الحركي

Note:

static friction force (the body is fixed) \vec{f}_s :

$$\vec{f}_s = \mu_s \vec{R}_n$$

μ_s : the static friction coefficient. معامل الاحتكاك السكوني

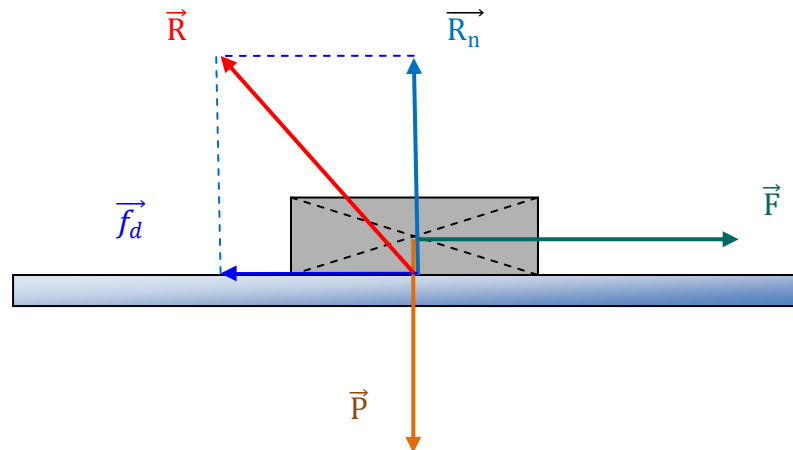

□ Friction forces in fluids

When a solid body moves in a fluid (gas or liquid), a friction force appears.

It is calculated by the formula:

$$\vec{f}_f = -k\eta\vec{v}$$

k is the coefficient which depends on the shape of the solid body and η is the viscosity coefficient.

c) Tension forces:

A tension force is a force developed in a rope or spring when it is stretched by an applied force. Tension is exerted along the entire length of the rope/spring in a direction opposite to the force applied to it. Tension can also sometimes be called stress, strain, or strain.

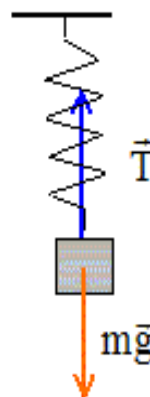

II.6. Cinematic moment (Angular momentum)

II.6.1. Angular momentum of a material point

We call angular momentum noted (\vec{L}_O) of point M rotating around a point O, the moment of its quantity of movement $\vec{P} = m\vec{v}$:

$$\vec{L}_O = \vec{OM} \wedge \vec{P} = \vec{r} \wedge m\vec{v}$$

The unit of angular momentum: $\text{Kg.m}^2.\text{s}^{-1}$

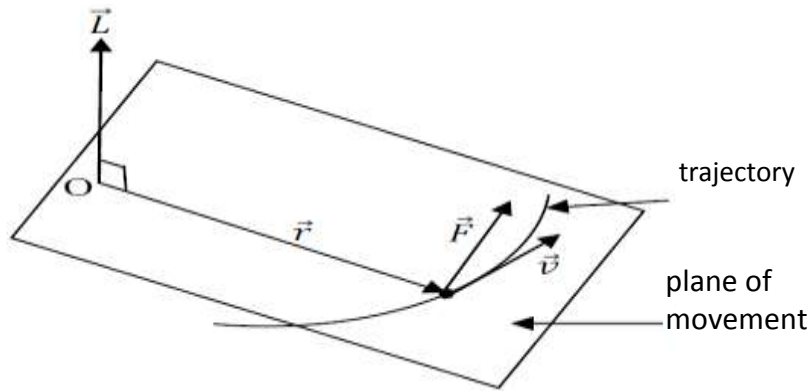

The angular momentum is a vector perpendicular to the plane containing the vectors \vec{r} and \vec{P} .

□ If the movement is circular with radius r, we will have

$$\vec{r} \perp \vec{v} \text{ and } v = \omega r$$

$$\vec{L}_O = \vec{r} \wedge m\vec{v} \Rightarrow L_O = r \cdot mv \cdot \sin \frac{\pi}{2} = rmv = mr^2\omega$$

$$\vec{L}_O = mr^2\vec{\omega}$$

□ For a curvilinear plane movement, we use polar coordinates, with pole O:

$$\vec{v} = \dot{r}\vec{u}_r + r\dot{\theta}\vec{u}_\theta$$

$$\vec{L}_O = \vec{r} \wedge m\vec{v} = m\vec{r} \wedge \vec{v} = m\vec{r} \wedge (\dot{r}\vec{u}_r + r\dot{\theta}\vec{u}_\theta) = mr^2\dot{\theta}\vec{k} \Rightarrow L_O = mr^2\dot{\theta}$$

II.6.2. Angular momentum theorem

At a fixed point O of a Galilean frame of reference, the derivative with respect to time of the angular momentum of a material point is equal to the sum of the moments of all the forces applied to it.

$$\frac{d\vec{L}_O}{dt} = \vec{\mathcal{M}}_{/O} \left(\sum \vec{F}_{ext} \right)$$

Proof:

$$\begin{aligned} \vec{L}_O &= \vec{r} \wedge \vec{P} = \vec{r} \wedge m\vec{v} \Rightarrow \frac{d\vec{L}_O}{dt} = \frac{d\vec{r}}{dt} \wedge m\vec{v} + \vec{r} \wedge \frac{dm\vec{v}}{dt} = \vec{v} \wedge m\vec{v} + \vec{r} \wedge \frac{m d\vec{v}}{dt} \\ &= \vec{r} \wedge m\vec{a} = \vec{r} \wedge \vec{F} = \vec{\mathcal{M}}_{/O}(\vec{F}) \end{aligned}$$

II.6.3. Conservation of angular momentum – central forces

a. Definition of a central force

We call “Central force” any force acting on a material point and having the following properties:

* It is carried by the line joining the material point to a fixed point O (center of force).

* Its module depends only on the distance “r” to the point O:

$$\vec{F} = f(r)\vec{u}_r \text{ and } \vec{OM} = r\vec{u}_r .$$

Examples:

-The gravitational force is a central force:

$$\vec{F}_g = G \frac{m_1 m_2}{r^2} \vec{u}_r = \frac{k}{r^2} \vec{u}_r$$

-The Coulomb force between 2 electric charges is a central force:

$$\vec{F}_e = K \frac{q_1 q_2}{r^2} \vec{u}_r = \frac{k}{r^2} \vec{u}_r$$

b. Conservation of angular momentum

The derivative of angular momentum vanishes (=0) if:

a. The particle is isolated $\sum \vec{F}_{ext} = \vec{0}$: which means that the angular momentum

of a free particle is constant $\frac{d\vec{L}_O}{dt} = \vec{0} \Rightarrow L_O = cte$

b. If the force \vec{F} is central: \vec{F} is parallel to \vec{r} , so the angular momentum relative to the center of forces is constant.

$$\frac{d\vec{L}_O}{dt} = \vec{\mathcal{M}}_{/O} \left(\sum \vec{F}_{ext} \right) = \vec{r} \wedge \vec{F} = \vec{0}(\vec{r} // \vec{F}) \Rightarrow \vec{L}_O = cte(\vec{L}_O \text{ is conserved})$$

The opposite is true; if the angular momentum is constant then the **force is central**.

II.6.4. Inertia forces or pseudo forces: a non-Galilean frame reference

Let R be a Galilean frame of reference and R' a non-Galilean frame of reference. R' is mobile relative to R. The law of composition of accelerations gives:

$$\vec{a}_a = \vec{a}_r + \vec{a}_e + \vec{a}_c$$

The fundamental principle of dynamics in a Galilean frame R is written:

$$\sum \vec{F}_{ext} = m\vec{a}_a = m \frac{d\vec{v}_a}{dt}$$

\vec{a}_a and \vec{v}_a are the absolute acceleration and speed.

In the non-Galilean (relative) frame R', the fundamental principle of dynamics is:

$$\vec{a}_r = \vec{a}_a - \vec{a}_e - \vec{a}_c \Rightarrow m\vec{a}_r = m\vec{a}_a - m\vec{a}_e - m\vec{a}_c \Rightarrow m\vec{a}_r = \sum \vec{F}_{ext} + \vec{F}_e + \vec{F}_c$$

with $\vec{F}_e = -m\vec{a}_e$ (force of inertia of Entrainment), $\vec{F}_c = -m\vec{a}_c$ (force of Coriolis inertia) are pseudo forces or forces of 'inertia'. Therefore, the law of dynamics can be applied in a non-Galilean frame of reference provided that the Entrainment inertia force and the Coriolis inertia force are added.

Exercises

Exercise 1

Calculate the gravitational field of a body of mass m :

- a- On the surface of the earth,
- b- At a height h from the earth.

$m_t = 5.98 \times 10^{24} \text{ kg}$, the mass of the earth

$r_t = 6.37 \times 10^6 \text{ m}$ the radius of the earth,

Exercise 2

Let a spring be fixed at one of these ends, we hang a mass m at the other end. When the spring extends, a restoring force is exerted on the mass, proportional to this elongation and called tension.

Determine the differential equation of motion using the PFD.

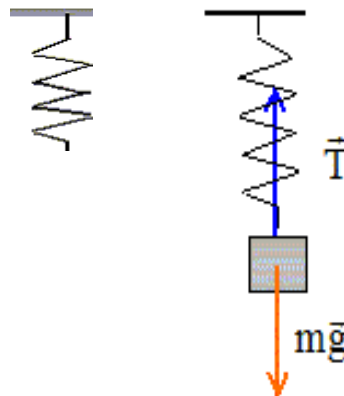

Exercise 3

A simple pendulum consists of a mass m considered point fixed to the free end of a wire of length l , we move the mass away from its initial position by an angle θ_0 , and we release it without initial speed, we neglect air friction.

Determine the differential equation of motion using:

- a) The fundamental principle of dynamics FPD (use the polar coordinate system) in a Galilean frame R .

- b) The fundamental principle of dynamics FPD in the non-Galilean (relative) frame R'
- c) The angular momentum theorem.

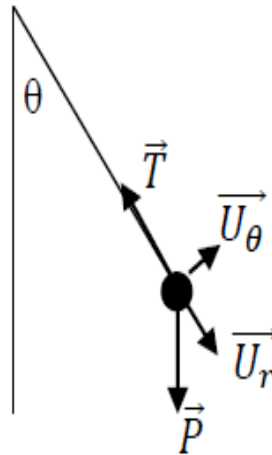

Exercise 4

A projectile of mass m is launched into the Earth's gravity field with a velocity vector v_0 making an angle α with the horizontal. Friction forces are negligible. Then study the movement of the projectile.

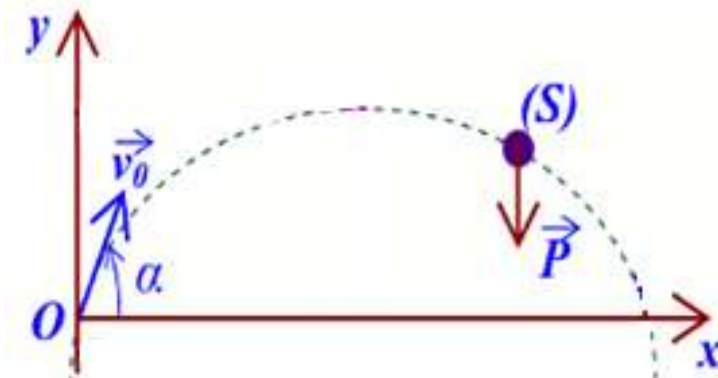

Exercise 5

A brick of mass m is kept in balance on a plane inclined at an angle α relative to the horizontal by an inelastic wire of negligible mass. The contact between the solid and the inclined plane is frictionless.

1. Remember the condition under which the solid is in equilibrium.

2. Find the expressions for the tension T of the wire and the reaction N of the plane as a function of m, g and α
3. We cut the wire, deduce the expression for the acceleration of the brick. What is the nature of the movement?

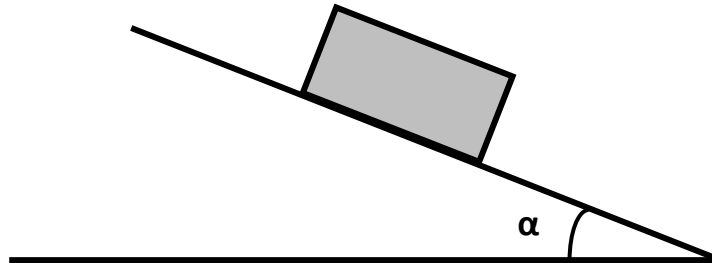

Solution

Exercise 1

a- On the surface of the earth:

$$F_g = G \frac{m_t m}{r_t^2} = mg \Rightarrow g = G \frac{m_t}{r_t^2}$$

$$\text{AN : } g = 6.67 \times 10^{-11} \frac{5.98 \times 10^{24}}{(6.37 \times 10^6)^2} = 9.82 \text{ m.s}^{-2}$$

$$\boxed{g = 9.82 \text{ m.s}^{-2}}$$

b- At a height h from the earth.

$$F_{g'} = G \frac{m_t m}{(r_t + h)^2} = mg' \Rightarrow g' = G \frac{m_t}{(r_t + h)^2}$$

$$\boxed{F_{g'} = G \frac{m_t}{(r_t + h)^2}}$$

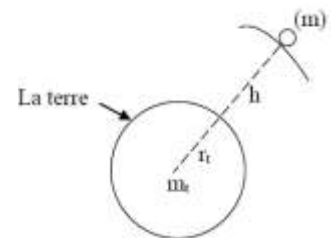
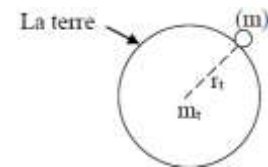

Exercise 2

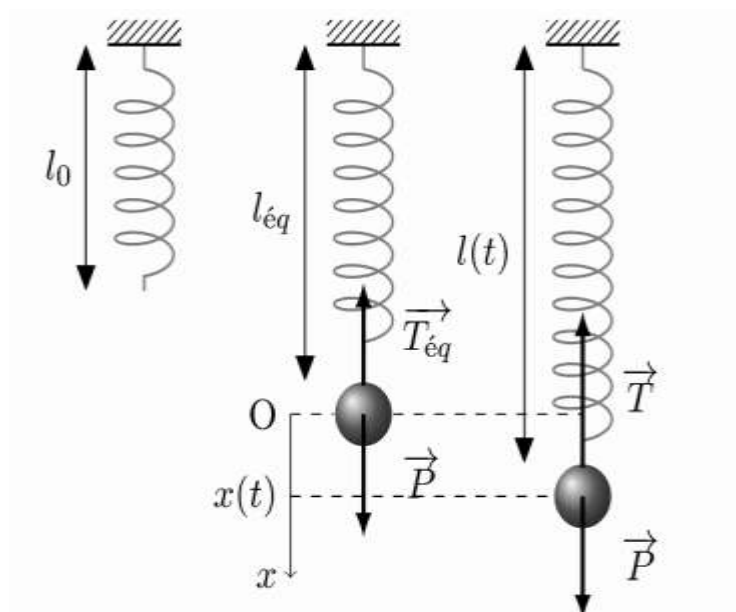

At equilibrium:

$$\sum \vec{F}_{ext} = \vec{P} + \vec{T} = \vec{0} \Rightarrow \vec{T} = -\vec{P} \Rightarrow T = mg$$

$$T = mg = k(l_{eq} - l_0) = kx_0$$

k : spring stiffness constant

l : length of the spring at time t , l_0 : length of the spring when empty.

By giving an elongation x to the spring then leaving the system alone, it executes oscillations. Newton's law gives:

$$\sum \vec{F}_{ext} = \vec{P} + \vec{T} = m\vec{a} \Rightarrow m\vec{g} + \vec{T} = m\vec{a}$$

By projection on (OX):

$$mg - T = mg - k(x + x_0) = m\ddot{x}$$

$$mg - kx_0 - kx = m\ddot{x} \quad (mg = kx_0)$$

$$m\ddot{x} + kx = 0$$

$$\omega_0^2 = \frac{k}{m} \Rightarrow \boxed{\ddot{x} + \omega_0^2 x = 0}$$

Solution of the equation: $x = A \cos(\omega t + \varphi)$

Exercise 3

a) Determine the differential equation of motion using to the PFD (use the polar coordinate system) in a Galilean frame R:

$$\sum \vec{F}_{ext} = m\vec{a} \Rightarrow \vec{P} + \vec{T} = m\vec{a}$$

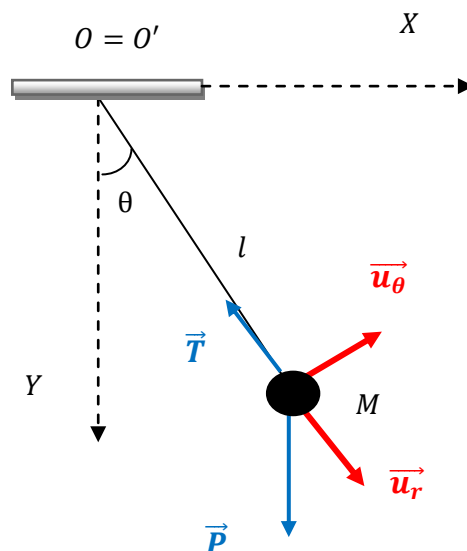

By projecting onto the polar base:

$$mg\cos\theta - T = ma_r$$

$$-mg\sin\theta = ma_\theta$$

$$r = \text{Cte} = l$$

$$\vec{a} = (\ddot{r} - r\dot{\theta}^2)\vec{u}_r + (2\dot{r}\dot{\theta} + r\ddot{\theta})\vec{u}_\theta \Rightarrow \vec{a} = \begin{cases} a_r = l\dot{\theta}^2 \\ a_\theta = l\ddot{\theta} \end{cases}$$

$$mg\cos\theta - T = ml\dot{\theta}^2$$

$$-mg\sin\theta = ml\ddot{\theta} \Rightarrow \ddot{\theta} + \frac{g}{l}\sin\theta = 0$$

$$\text{If } \theta \ll 1 \Rightarrow \sin\theta \approx \theta, \Rightarrow \ddot{\theta} + \frac{g}{l}\theta = 0$$

$$\text{We pose } \omega^2 = \frac{g}{l} \Rightarrow \boxed{\ddot{\theta} + \omega^2\theta = 0}$$

The equation of motion of the pendulum is a second order differential equation, its solution is:

$$\theta(t) = A_1\cos\omega t + A_2\sin\omega t$$

b) Determine the differential equation of motion, using the PFD in the non-Galilean (relative) frame R':

we use the cylindrical base $(\vec{u}_r, \vec{u}_\theta, \vec{k})$

$$\sum \vec{F}_{ext} = m\vec{a}_a$$

$$\vec{a}_a = \vec{a}_r + \vec{a}_e + \vec{a}_c \Rightarrow \sum \vec{F}_{ext} = m\vec{a}_r + m\vec{a}_e + m\vec{a}_c$$

$$\Rightarrow m\vec{a}_r = \sum \vec{F}_{ext} - m\vec{a}_e - m\vec{a}_c = \sum \vec{F}_{ext} + \vec{F}_e + \vec{F}_c$$

$$\left\{ \begin{array}{l} \vec{F}_e = -m\vec{a}_e \text{ (force of inertia of Entrainment)} \\ \vec{F}_c = -m\vec{a}_c \text{ (force of Coriolis inertia)} \end{array} \right.$$

$$\left\{ \begin{array}{l} \vec{F}_e = -m\vec{a}_e \text{ (force of inertia of Entrainment)} \\ \vec{F}_c = -m\vec{a}_c \text{ (force of Coriolis inertia)} \end{array} \right.$$

$$\vec{a}_{re} = \frac{d\vec{v}_r}{dt}\Big|_{R'} = \frac{d\vec{OM}}{dt}\Big|_{R'} = \vec{0} \quad (\vec{OM} = \vec{O'M} = l\vec{u}_r = c\vec{st} \Rightarrow \frac{d\vec{OM}}{dt}\Big|_{R'} = \vec{0})$$

$$m\vec{a}_r = \sum \vec{F}_{ext} - m\vec{a}_e - m\vec{a}_c = \sum \vec{F}_{ext} + \vec{F}_e + \vec{F}_c = \vec{0}$$

In the cylindrical base we have: $\vec{a} = \begin{cases} a_r = \ddot{r} - r\dot{\theta}^2 \\ a_\theta = 2\dot{r}\dot{\theta} + r\ddot{\theta} \\ a_z = \ddot{z} \end{cases}$

$$\vec{a}_e = \left. \frac{d^2 \overrightarrow{OO'}}{dt^2} \right|_R + \frac{d\vec{\omega}}{dt} \wedge \overrightarrow{O'M} + \vec{\omega} \wedge (\vec{\omega} \wedge \overrightarrow{O'M}) = \vec{0} + \frac{d\omega \vec{k}}{dt} \wedge l \vec{u}_r + \omega \vec{k} \wedge (\omega \vec{k} \wedge l \vec{u}_r)$$

$$\vec{a}_e = \ddot{\theta} \vec{k} \wedge l \vec{u}_r + \dot{\theta} \vec{k} \wedge (\dot{\theta} \vec{k} \wedge l \vec{u}_r) = l \ddot{\theta} \vec{u}_\theta - l \dot{\theta}^2 \vec{u}_r$$

$$\vec{a}_c = 2\vec{\omega} \wedge \vec{v}_r \cdot \vec{a}_c = 2\vec{\omega} \wedge \vec{0} = \vec{0}$$

$$\sum \overrightarrow{F_{ext}} + ml\dot{\theta}^2 \vec{u}_r - ml\ddot{\theta} \vec{u}_\theta = \vec{P} + \vec{T} + ml\dot{\theta}^2 \vec{u}_r - ml\ddot{\theta} \vec{u}_\theta = \vec{0}$$

By projecting onto the polar base:

$$mg \cos \theta - T + ml\dot{\theta}^2 = 0$$

$$-mg \sin \theta - ml\ddot{\theta} = 0 \Rightarrow \ddot{\theta} + \frac{g}{l} \sin \theta = 0$$

$$\text{If } \theta \ll 1 \Rightarrow \sin \theta \approx \theta, \Rightarrow \ddot{\theta} + \frac{g}{l} \theta = 0$$

$$\text{We pose } \omega^2 = \frac{g}{l} \Rightarrow \boxed{\ddot{\theta} + \omega^2 \theta = 0}$$

c) Determine the differential equation of motion, using the angular momentum theorem:

$$\frac{d\vec{L}_O}{dt} = \sum \vec{\mathcal{M}}_{/O} \left(\sum \overrightarrow{F_{ext}} \right)$$

$$\vec{L}_O = \overrightarrow{OM} \wedge \vec{p} = \overrightarrow{OM} \wedge m\vec{v}$$

□ we use polar coordinates, with pole O:

$$\vec{v} = \dot{r} \vec{u}_r + r \dot{\theta} \vec{u}_\theta \quad \text{and } r = \text{Cte} = l$$

$$\vec{L}_O = m \overrightarrow{OM} \wedge \vec{v} = m \overrightarrow{OM} \wedge (0 \vec{u}_r + l \dot{\theta} \vec{u}_\theta) = ml^2 \dot{\theta} \vec{k} \Rightarrow L_O = ml^2 \dot{\theta}$$

$$\boxed{\frac{dL_O}{dt} = ml^2 \ddot{\theta} \vec{k}} \quad (1)$$

$$\sum \vec{\mathcal{M}}_{/O} \left(\sum \overrightarrow{F_{ext}} \right) = \vec{\mathcal{M}}_{/O}(\vec{P}) + \vec{\mathcal{M}}_{/O}(\vec{T}) = \overrightarrow{OM} \wedge \vec{P} + \overrightarrow{OM} \wedge \vec{T}$$

$$\overline{OM} \wedge \vec{P} = l\vec{u}_r \wedge (mg\cos\theta\vec{u}_r - mg\sin\theta\vec{u}_\theta) = -lmgsin\theta\vec{k}$$

$$\overline{OM} \wedge \vec{T} = l\vec{u}_r \wedge -T.\vec{u}_r = \vec{0}$$

$$\boxed{\sum \vec{M}_{/O}(\sum \vec{F}_{ext}) = -lmgsin\theta\vec{k}} \quad (2)$$

$$(1) = (2) \Rightarrow ml^2\ddot{\theta}\vec{k} = -lmgsin\theta\vec{k}$$

$$ml^2\ddot{\theta} = -lmgsin\theta \Rightarrow \boxed{\ddot{\theta} + \frac{g}{l}\sin\theta = 0}$$

$$\text{If } \theta \ll \Rightarrow \sin\theta \approx \theta, \Rightarrow \ddot{\theta} + \frac{g}{l}\theta = 0$$

$$\text{We pose } \omega^2 = \frac{g}{l} \Rightarrow \boxed{\ddot{\theta} + \omega^2\theta = 0}$$

Exercise 4

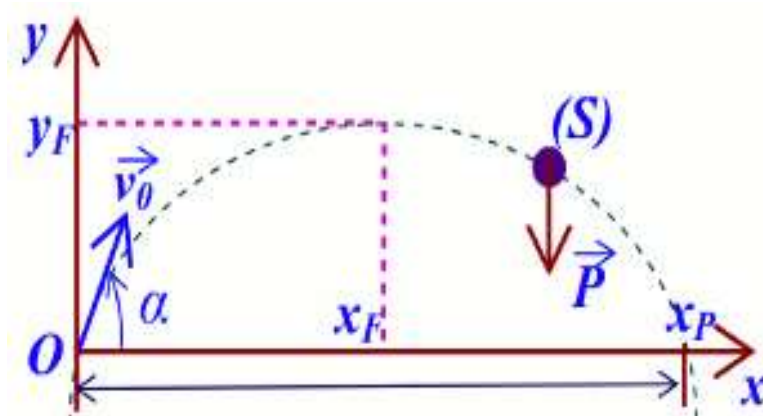

We can predict the movement of a projectile launched with an initial speed v_0 making an angle with the horizontal by:

$$\vec{a} = -g\vec{j} \Rightarrow \vec{a} \begin{pmatrix} 0 \\ -g \end{pmatrix}$$

We decompose the movement of M along the 2 axes OX and OY:

According to OX:

Accélération a_x :

$$a_x = 0 = \frac{dv_x}{dt} \Rightarrow v_x = cte = v_{0x} = v_0 \cos \alpha$$

$$v_x = v_0 \cos \alpha = \frac{dx}{dt} \Rightarrow dx = v_x dt \Rightarrow x - x_0 = v_x t$$

$$x = x_0 + v_x t$$

From the initial conditions:

$$\text{At } t=0: \begin{cases} v_x(0) = v_{0x} = v_0 \cos \alpha \\ x(0) = x_0 = 0 \end{cases}$$

$$\boxed{x = v_0 \cos \alpha \cdot t}$$

According to OY:

Accélération a_y :

$$a_y = -g = \frac{dv_y}{dt} \Rightarrow v_y - v_{0y} = -gt$$

$$v_y - v_{0y} = -gt$$

$$v_y = -gt + v_0 \sin \alpha$$

$$v_y = -gt + v_0 \sin \alpha = \frac{dy}{dt} \Rightarrow dy = v_y dt \Rightarrow y - y_0 = v_y t$$

From the initial conditions:

$$\text{At } t=0: \begin{cases} v_y(0) = v_{0y} = v_0 \sin \alpha \\ y(0) = y_0 = 0 \end{cases}$$

$$\boxed{y = -\frac{1}{2}gt^2 + v_0 \sin \alpha \cdot t}$$

The trajectory equation:

$$\begin{aligned} t = \frac{x}{v_0 \cos \alpha} \Rightarrow y &= -\frac{1}{2}g \left(\frac{x}{v_0 \cos \alpha} \right)^2 + v_0 \sin \alpha \cdot \left(\frac{x}{v_0 \cos \alpha} \right) \\ &= -\frac{g}{2v_0^2 \cos^2 \alpha} x^2 + \tan \alpha \cdot x \end{aligned}$$

$$y = -\frac{g}{2v_0^2 \cos^2 \alpha} x^2 + \tan \alpha \cdot x$$

The maximum altitude h الذروة:

$$v_y(t_M) = 0 = -gt_M + v_0 \sin \alpha \Rightarrow t_M = \frac{v_0 \sin \alpha}{g}$$

$$\Rightarrow \boxed{t_M = \frac{v_0 \sin \alpha}{g}}$$

(t_M : peak time).

$$h = y(t_M) = -\frac{1}{2}gt_M^2 + v_0 \sin \alpha \cdot t_M = -\frac{1}{2}g \left(\frac{v_0 \sin \alpha}{g} \right)^2 + v_0 \frac{v_0 \sin \alpha}{g} \sin \alpha$$

$$\boxed{h = \frac{(v_0 \sin \alpha)^2}{2g}}$$

The time for which the projectile reaches point I:

$$y(t_P) = 0 = -\frac{1}{2}gt_P^2 + v_0 \sin \alpha \cdot t_P = t_P \left(-\frac{1}{2}gt_P + v_0 \sin \alpha \right)$$

$$\Rightarrow \left\{ \begin{array}{l} t_p = 0 \\ t_p = \frac{2v_0 \sin \alpha}{g} \end{array} \right.$$

Calculation of x_p range:

replaces t_p in $x(t)$:

$$x(t_p) = v_0 \cos \alpha \cdot \frac{2v_0 \sin \alpha}{g} = \frac{2v_0^2 \cos \alpha \sin \alpha}{g}$$

$$2\cos \alpha \sin \alpha = \sin 2\alpha ,$$

So :

$$\boxed{x_p = \frac{v_0^2 \sin 2\alpha}{g}}$$

Exercise 5

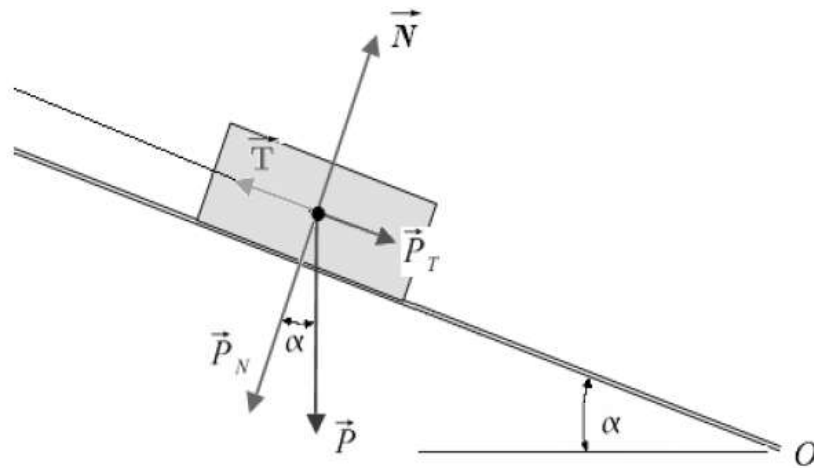

1. Equilibrium condition :

$$\sum \vec{F}_{ext} = \vec{0}$$

$$\vec{P} + \vec{N} + \vec{T} = \vec{0}$$

2. Expression of T and N :

By projection on the tangential axis (OX) :

$$P_T + 0 - T = 0 \Rightarrow T = P_T = mg \sin \alpha$$

$$\boxed{T = mg \sin \alpha}$$

By projection on the normal axis (OY)

$$-P_N + N + 0 = 0 \Rightarrow N = P_N = mg \cos \alpha$$

$$\boxed{N = mg \cos \alpha}$$

3. Acceleration of the brick:

Once the wire is cut, the tension T no longer exists, so we write the PFD :

$$\sum \vec{F}_{ext} = m\vec{a} \Rightarrow \vec{P} + \vec{N} = m\vec{a}$$

By projection on the tangential axis (OX) :

$$P_T + 0 = ma \Rightarrow mg \sin\alpha = ma$$

$$\boxed{a = g \sin\alpha}$$

Chapter 3

Work and Energy

III.1. Work

III.1.1. Elementary work

Consider a constant force \vec{F} acting on a material point M. We define the elementary work dW of the force \vec{F} by:

$$dW = \vec{F} \cdot d\vec{l}$$

$d\vec{l}$ is the elementary displacement.

$$\vec{F} = F_x \vec{i} + F_y \vec{j} + F_z \vec{k}$$

$$d\vec{l} = dx \vec{i} + dy \vec{j} + dz \vec{k}$$

$$dW = F_x \cdot dx + F_y \cdot dy + F_z \cdot dz$$

The work of a force \vec{F} applied to a material point moving from point A to point B is:

$$W_{A \rightarrow B}(\vec{F}) = \int_A^B dW = \int_A^B \vec{F} \cdot d\vec{l}$$

The unit of work, in the SI system, is the **Joule**.

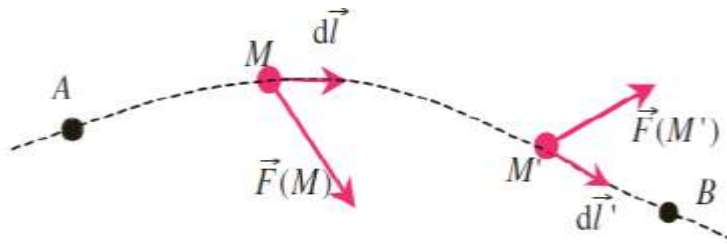

Remark:

Force \vec{F} can be decomposed into two vectors:

- $\vec{F}_{//}$ parallel to the displacement $d\vec{l}$,
- \vec{F}_{\perp} perpendicular to the displacement $d\vec{l}$

$$W_{A \rightarrow B}(\vec{F}) = \int_A^B \vec{F} \cdot d\vec{l} = \int_A^B (\vec{F}_{//} + \vec{F}_{\perp}) \cdot d\vec{l}$$

Where $\vec{F}_{\perp} \cdot d\vec{l} = 0$ so:

$$W_{A \rightarrow B}(\vec{F}) = \int_A^B \vec{F} \cdot d\vec{l} = \int_A^B \vec{F}_{//} \cdot d\vec{l}$$

Hence only the component of the force parallel to the displacement $\vec{F}_{//}$ provides work, the work of the force perpendicular to the displacement is zero.

III.2. Constant force on a rectilinear movement:

Consider a material point M moving on the line segment [AB] under the effect of a force \vec{F} .

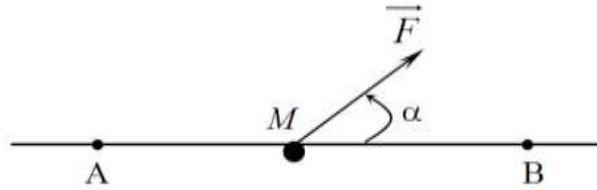

By definition, the work of the force \vec{F} on the rectilinear displacement AB is given by:

$$W_{A \rightarrow B}(\vec{F}) = \vec{F} \cdot \overrightarrow{AB} = F \cdot AB \cdot \cos \alpha$$

α is the angle that \vec{F} makes with \overrightarrow{AB} .

This work is

- positive (motor work) if the force is in the direction of movement (driving force):

$$\cos \alpha > 0 \Rightarrow 0 < \alpha < \pi/2$$

- Negative (resistant work) if the force is in the direction opposite to the displacement (force resisting):

$$\cos \alpha < 0 \Rightarrow \pi/2 < \alpha < \pi$$

- zero if the force is perpendicular to the displacement: $\cos \alpha = 0 \Rightarrow \alpha = \frac{\pi}{2}$

Example

calculate the work of the forces: \vec{P} , \vec{R} and \vec{f}

$$W_{A \rightarrow B}(\vec{P}) = \vec{P} \cdot \overrightarrow{AB} = P \cdot AB \cdot \cos\left(\frac{\pi}{2} - \alpha\right) = P \cdot AB \cdot \sin \alpha$$

$$W_{A \rightarrow B}(\vec{P}) = P \cdot AB \cdot \sin \alpha$$

$$W_{A \rightarrow B}(\vec{R}) = \vec{R} \cdot \overrightarrow{AB} = R \cdot AB \cdot \cos \pi/2 = 0$$

$$W_{A \rightarrow B}(\vec{R}) = 0$$

$$W_{A \rightarrow B}(\vec{f}) = \vec{f} \cdot \overrightarrow{AB} = f \cdot AB \cdot \cos \pi = -f \cdot AB$$

$$W_{A \rightarrow B}(\vec{f}) = -f \cdot AB$$

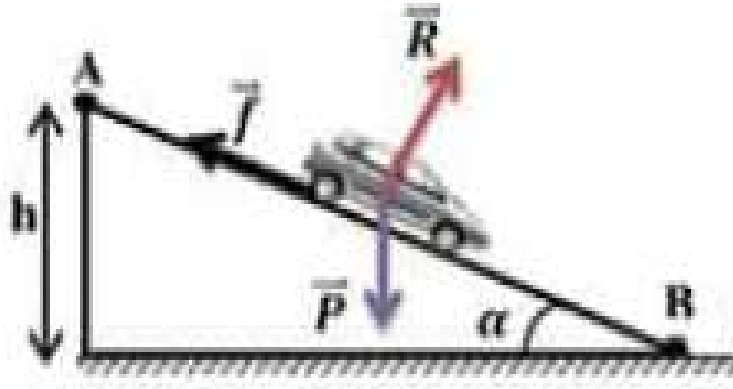

III.3. Power

The power of a force \vec{F} is the ratio of its work to the time taken to accomplish it.

$$\text{Average power: } P_{\text{moy}} = \frac{W_{AB}}{\Delta t}$$

$$\text{Instantaneous power: } P(t) = \frac{dW_{AB}}{dt}$$

The unit of power, in the SI system, is the Watt.

III.4. Kinetic energy

Let's calculate the work of the resultant of the force \vec{F} applied to a material point of mass m between two points A and B.

$$W_{A \rightarrow B}(\vec{F}) = \int_A^B \vec{F} \cdot d\vec{l}$$

Now according to the fundamental principle of dynamics we have:

$$\vec{F} = m\vec{a} = m \frac{d\vec{V}}{dt}$$

$$W_{A \rightarrow B}(\vec{F}) = \int_A^B m \frac{d\vec{V}}{dt} \cdot d\vec{l} = \int_A^B m \cdot d\vec{V} \cdot \frac{d\vec{l}}{dt} = \int_A^B m \cdot \vec{V} \cdot d\vec{V}$$

Where $\frac{d\vec{l}}{dt} = \vec{V}$

However, since the displacement is very small, we can consider it as rectilinear, then the vectors are parallel. The work then becomes:

$$W_{A \rightarrow B}(\vec{F}) = \int_A^B m \cdot V \cdot dV = m \int_A^B V dV = m \left[\frac{1}{2} V^2 \right]_A^B = \frac{1}{2} m V_B^2 - \frac{1}{2} m V_A^2$$

$$W_{A \rightarrow B}(\vec{F}) = \frac{1}{2} m V_B^2 - \frac{1}{2} m V_A^2$$

The value $E_C = \frac{1}{2} m V^2$ is called the kinetic energy of the material point.

III.4.1. Kinetic energy theorem

“The work of the resultant of the forces applied to a material point between two points is equal to the variation of the kinetic energy of the material point »

$$W_{A \rightarrow B}(\vec{F}) = \Delta E_C = E_C(B) - E_C(A)$$

III.5. Potential Energy

III.5.1. Conservative force and non-conservative force

- A force is said to be conservative if its work between two points A and B does not depend on the path followed (W_1 , W_2 , and W_3), but only from the starting point A and the ending point B.

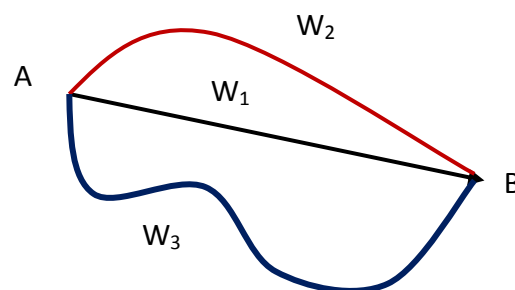

- Any conservative force derives from a potential function $E_p(x, y, z)$ such that

$$\vec{F} = -\overrightarrow{\text{grad}} E_p(x, y, z)$$

$$F_x \vec{i} + F_y \vec{j} + F_z \vec{k} = -\frac{\partial E_p}{\partial x} \vec{i} - \frac{\partial E_p}{\partial y} \vec{j} - \frac{\partial E_p}{\partial z} \vec{k}$$

Examples: Force of gravity; force of weight; spring return force.

Remark:

If a force \vec{F} is conservative, its rotational is zero:

$$\overrightarrow{rot} \vec{F} = \vec{\nabla} \wedge \vec{F} = \vec{0}$$

- The forces are called non-conservative when their work depends on the path followed.

Example: Friction force.

III.6. Potential energy

- ✓ Potential energy is the potential function associated with the conservative force.
- ✓ Potential energy is the energy related to position.
- ✓ Potential energy is defined up to a constant; it is always referred to a reference frame taken as the origin to calculate it.
- ✓ The work of a conservative force is related to the potential energy by the expression:

$$W_{A \rightarrow B}(\vec{F}) = -\Delta E_p = E_p(A) - E_p(B)$$

III.7. Total Mechanical Energy

The mechanical (total) energy of a material point is the sum of kinetic and potential energies:

$$E_M = E_p + E_C$$

III.7.1. Principle of Conservation of Mechanical Energy

- ❖ The mechanical energy of a material point subjected to conservative forces is conserved.

$$E_M(A) = E_M(B) \Rightarrow E_p(A) + E_C(A) = E_p(B) + E_C(B) = cst$$

$$E_M(A) = E_M(B) = cst$$

The variation in mechanical energy is zero

$$\Delta E_M = 0$$

❖ If one of the forces is not conservative, the mechanical energy is not conserved.

The variation of the mechanical energy between two points A and B is equal to the sum of the work of the non-conservative forces between these two points.

$$\Delta E_M = \sum_i W(\vec{F}_{nc})$$

Such that \vec{F}_{nc} are the non-conservative forces

III.7.2. Examples of conservative forces

a) Force of gravity

$$\vec{F}_g = -G \frac{Mm}{r^2} \vec{u} \Rightarrow \vec{F}_g = -\overrightarrow{\text{grad}} E_p(r) = -\frac{dE_p}{dr} \vec{u}$$

$$G \frac{Mm}{r^2} = \frac{dE_p}{dr} \Rightarrow dE_p = G \frac{Mm}{r^2} dr$$

$$E_p(r) = \int G \frac{Mm}{r^2} dr$$

$$E_p(r) = G \frac{Mm}{r} + cst$$

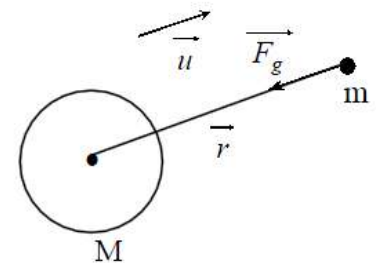

b) Elastic force

$$\vec{F} = -kx\vec{i} \Rightarrow \vec{F} = -\overrightarrow{\text{grad}} E_p(x) = -\frac{dE_p}{dx} \vec{i}$$

$$dE_p = kx dx$$

$$E_p(x) = \int kx dx = \frac{1}{2} kx^2 + cste$$

$$E_p(x) = \frac{1}{2} kx^2 + cst$$

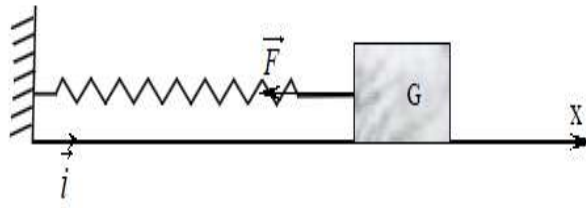
**c) Electric force**

$$\vec{F}_e = -K \frac{Qq}{r^2} \vec{u}$$

Following the same reasoning as above, we will have:

$$E_p(r) = -K \frac{Qq}{r} + cst$$

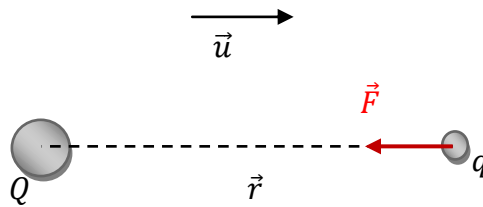

Exercises

Exercise 1

A simple pendulum consists of a mass m considered point fixed to the free end of a wire of length l , we move the mass away from its initial position by an angle θ_0 , and we release it without initial speed, we neglect air friction.

Determine the differential equation of motion using:

- a) The kinetic energy theorem.
- b) The total mechanical energy theorem.

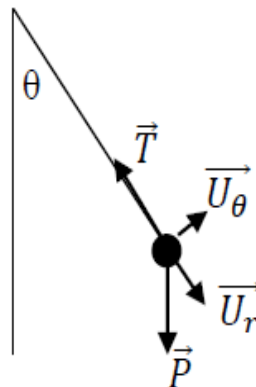

Exercise 2

Let a material point M be subject to a force field F .

$$\vec{F} = (x - ay)\vec{i} + (3y - 2x)\vec{j}$$

1. Calculate the work of the force F for the displacement of M from the point $O(0,0)$ to the point $A(2,4)$ passing through the point $C(0,4)$.
2. Find the value of a so that F is conservative, deduce the energy potential E_p resulting from this force field.
3. Determine the work of F for the displacement of M following a trajectory circular with radius R and center $O(0,0)$.

Solution

Exercise 1

a. Determine the differential equation of motion using the kinetic energy theorem:

$$W_{A \rightarrow B}(\vec{F}) = \Delta E_C = E_C(B) - E_C(A) \Rightarrow dW = dE_C$$

$$W = \vec{F} \cdot \vec{l} \Rightarrow dW = \vec{F} \cdot d\vec{l}$$

$$\vec{F} = \vec{P} + \vec{T} = m\vec{g} + \vec{T}$$

$$\vec{T} = -T\vec{u}_r$$

$$m\vec{g} = mg\cos\theta\vec{u}_r - mg\sin\theta\vec{u}_\theta$$

$$\vec{l} = l\vec{u}_r \Rightarrow d\vec{l} = l d\vec{u}_r = l d\theta \frac{d\vec{u}_r}{d\theta}$$

$$\frac{d\vec{u}_r}{d\theta} = \vec{u}_\theta$$

$$d\vec{l} = l d\theta \vec{u}_\theta$$

$$dW = \vec{F} \cdot d\vec{l} = (m\vec{g} + \vec{T})d\vec{l}$$

$$dW = (mg\cos\theta\vec{u}_r - mg\sin\theta\vec{u}_\theta - T\vec{u}_r)l d\theta \vec{u}_\theta$$

$$\vec{u}_\theta \cdot \vec{u}_r = 0 \quad \vec{u}_\theta \cdot \vec{u}_\theta = 1$$

$$dW = -mgl\sin\theta d\theta$$

$$E_C = \frac{1}{2}mv^2$$

$$v = l\dot{\theta}$$

$$E_C = \frac{1}{2}ml^2\dot{\theta}^2 \Rightarrow dE_C = ml^2\dot{\theta}d\theta$$

$$dW = dE_C \Rightarrow -mgl\sin\theta d\theta = ml^2\dot{\theta}d\theta$$

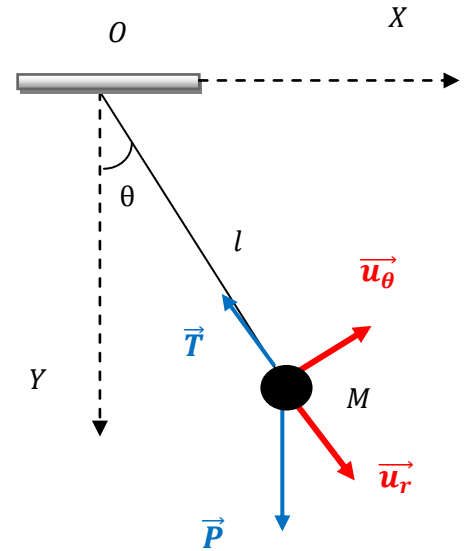

$$\ddot{\theta} + \frac{g}{l} \sin\theta = 0$$

If $\theta \ll 1 \Rightarrow \sin\theta \approx \theta, \Rightarrow \ddot{\theta} + \frac{g}{l}\theta = 0$

We pose $\omega^2 = \frac{g}{l} \Rightarrow \ddot{\theta} + \omega^2\theta = 0$

b. Determine the differential equation of motion using the total mechanical energy theorem:

$$E_M = E_P + E_C = \text{cte} \Rightarrow \frac{d}{dt}(E_P + E_C) = 0$$

We have calculated E_C in the previous answer:

$$E_C = \frac{1}{2} ml^2 \dot{\theta}^2$$

$$dW = -dE_p \dots \dots \dots (1)$$

$$dW = -mgl \sin\theta d\theta \dots \dots (2)$$

$$(1) = (2) \Rightarrow dE_p = mgl \sin\theta d\theta$$

$$E_p = \int mgl \sin\theta d\theta = -mgl \cos\theta + C$$

If $\theta = 0 \Rightarrow E_p = 0 \Rightarrow C = mgl$

$$E_p = mgl(1 - \cos\theta)$$

$$E_M = E_P + E_C = mgl(1 - \cos\theta) + \frac{1}{2} ml^2 \dot{\theta}^2 = \text{cte}$$

$$\frac{d}{dt}(E_P + E_C) = 0 \Rightarrow mgl \sin\theta + ml^2 \ddot{\theta} d\theta = 0$$

$$\ddot{\theta} + \frac{g}{l} \sin\theta = 0$$

If $\theta \ll 1 \Rightarrow \sin\theta \approx \theta, \Rightarrow \ddot{\theta} + \frac{g}{l}\theta = 0$

We pose $\omega^2 = \frac{g}{l} \Rightarrow \ddot{\theta} + \omega^2\theta = 0$

Exercise 2

$$\vec{F} = (x - ay)\vec{i} + (3y - 2x)\vec{j}$$

1. The work of the force F for the displacement of M from the point $O(0,0)$ to the point $A(2,4)$ passing through the point $C(0,4)$:

We know that:

$$dW = \vec{F} \cdot d\vec{l}$$

$d\vec{l}$ is the elementary displacement.

$$d\vec{l} = dx\vec{i} + dy\vec{j}$$

$$\vec{F} = F_x\vec{i} + F_y\vec{j} = (x - ay)\vec{i} + (3y - 2x)\vec{j}$$

$$dW = F_x \cdot dx + F_y \cdot dy$$

$$dW = (x - ay) \cdot dx + (3y - 2x) \cdot dy$$

$$W_{OCA} = W_{OC} + W_{CA}$$

$$\square \text{ The path from } O \rightarrow C: \begin{cases} x = 0 \Rightarrow dx = 0 \\ y \text{ varies from } 0 \rightarrow 4 \end{cases}$$

$$W_{OC} = \int_0^4 dW = \int_0^4 (3y - 2(0)) \cdot dy = \int_0^4 3y \cdot dy = \frac{3y^2}{2} \Big|_0^4 = \frac{3(4)^2}{2}$$

$$\boxed{W_{OC} = 24}$$

$$\square \text{ The path from } AC \rightarrow A: \begin{cases} x \text{ varies from } 0 \rightarrow 2 \\ y = 4 \Rightarrow dy = 0 \end{cases}$$

$$W_{CA} = \int_0^2 dW = \int_0^2 (x - a(4)) \cdot dx = \int_0^2 x \cdot dx - \int_0^2 4a dx = \frac{x^2}{2} \Big|_0^2 - 4ax \Big|_0^2$$

$$W_{CA} = \frac{2^2}{2} - 4a(2) = 2 - 8a$$

$$\boxed{W_{CA} = 2 - 8a}$$

$$W_{OCA} = W_{OC} + W_{CA} = 24 + 2 - 8a = 26 - 8a$$

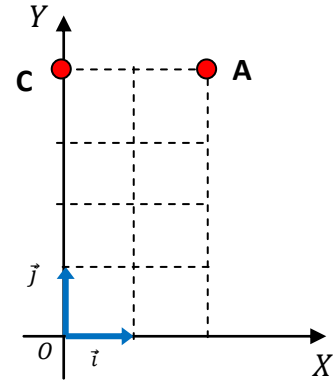

$$W_{OCA} = 26 - 8a$$

2. For the force to be conservative, it must verify:

$$\overrightarrow{\text{rot}} \vec{F} = \vec{0}$$

$$\overrightarrow{\text{rot}} \vec{F} = \vec{\nabla} \wedge \vec{F}$$

$$\vec{\nabla} = \frac{\partial}{\partial x} \vec{i} + \frac{\partial}{\partial y} \vec{j} + \frac{\partial}{\partial z} \vec{k}$$

$$\vec{F} = (x - ay)\vec{i} + (3y - 2x)\vec{j}$$

$$\vec{\nabla} \wedge \vec{F} = \begin{vmatrix} \vec{i} & -\vec{j} & \vec{k} \\ \frac{\partial}{\partial x} & \frac{\partial}{\partial y} & \frac{\partial}{\partial z} \\ x - ay & 3y - 2x & 0 \end{vmatrix}$$

$$\vec{\nabla} \wedge \vec{F} = -\frac{\partial}{\partial z} (3y - 2x)\vec{i} + \frac{\partial}{\partial z} (x - ay)\vec{j} + \left(-\frac{\partial}{\partial x} (3y - 2x) - \frac{\partial}{\partial y} (x - ay) \right) \vec{k}$$

$$\vec{\nabla} \wedge \vec{F} = (-2 + a)\vec{k}$$

$$\vec{\nabla} \wedge \vec{F} = (-2 + a)\vec{k} = \vec{0} \Rightarrow a = 2$$

For $a=2$, \vec{F} is conservative

3. The work of F for the displacement of M following a trajectory circular with radius R and center $O(0,0)$:

$$\vec{F} = (x - 2y)\vec{i} + (3y - 2x)\vec{j}$$

➤ \vec{F} is conservative force $\Rightarrow \vec{F}$ derives from a potential E_p :

$$\vec{F} = F_x \vec{i} + F_y \vec{j} + F_z \vec{k} = -\overrightarrow{\text{grad}} E_p = -\frac{\partial E_p}{\partial x} \vec{i} - \frac{\partial E_p}{\partial y} \vec{j} - \frac{\partial E_p}{\partial z} \vec{k}$$

$$(x - 2y)\vec{i} + (3y - 2x)\vec{j} = -\frac{\partial E_p}{\partial x} \vec{i} - \frac{\partial E_p}{\partial y} \vec{j}$$

$$\begin{cases} \frac{\partial E_p}{\partial x} = -(x - 2y) \dots \dots (1) \\ \frac{\partial E_p}{\partial y} = -(3y - 2x) \dots \dots (2) \end{cases}$$

$$\text{from (1)} \Rightarrow E_p = - \int (x - 2y) dx = -\frac{x^2}{2} + 2xy + C(y) \dots \dots (3)$$

$$\text{from (3)} \Rightarrow \frac{\partial E_p}{\partial y} = 2x + \frac{dC(y)}{dx} \dots \dots (4)$$

$$(4) = (2) \Rightarrow 2x + \frac{dC(y)}{dx} = -(3y - 2x) \Rightarrow \frac{dC(y)}{dx} = -3y$$

$$C(y) = -\frac{3y^2}{2} + C$$

$$\boxed{E_p = -\frac{x^2}{2} + 2xy - \frac{3y^2}{2} + C}$$

BIBLIOGRAPHY

BIBLIOGRAPHY

- ❑ M.A. Ruderman, W.D. Knight, C. Kittel: *Cours de physique de Berkeley*
Tome 1 – Mécanique.
- ❑ David Morin, *Introduction to Classical Mechanics: With Problems and*
Solutions.
- ❑ Ahmed Fizazi, *Mécanique du point Matériel, cours et exercices corrigés,*
l'office des publications universitaires, Alger, 2016.
- ❑ John R. Taylor, *Classical Mechanics*, University Science Books, 2005.
- ❑ Richard P. Feynman. *Mécanique* ,1 Inter Edition, Paris, 1979.